

1.25mm (0.049") PITCH CONNECTOR

Wire-to-Board
Housing

12507HS-NNL Series

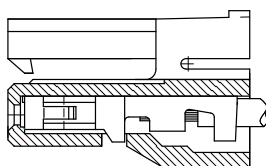
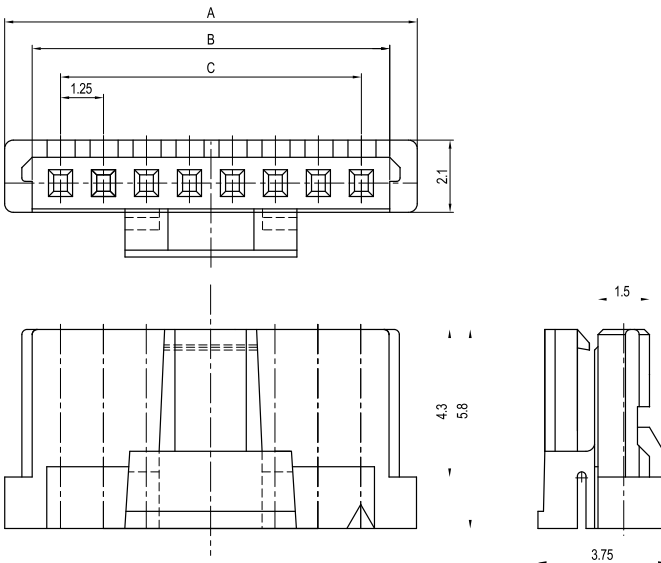
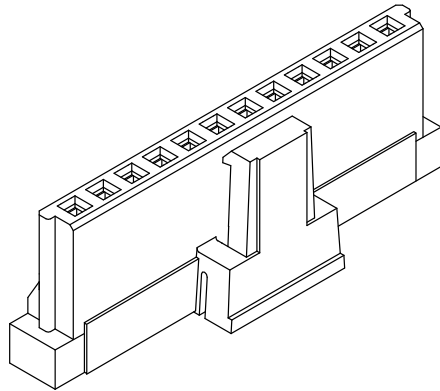

TERMINAL ASSEMBLY DRAWING

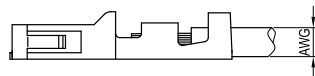

AWG : #26 ~ #32

Material

I/NO	DESCRIPTION	TITLE	MATERIAL
1	HOUSING	12507HS-NNL	PA66 or PBT, UL 94V Grade

Available Pin

PARTS NO.	A	B	C
12507HS-02L	4.50	2.90	1.25
12507HS-03L	5.75	4.15	2.50
12507HS-04L	7.00	5.40	3.75
12507HS-05L	8.25	6.65	5.00
12507HS-06L	9.50	7.90	6.25
12507HS-07L	10.75	9.15	7.50
12507HS-08L	12.00	10.40	8.75
12507HS-09L	13.25	11.65	10.00
12507HS-10L	14.50	12.90	11.25
12507HS-11L	15.75	14.15	12.50
12507HS-12L	17.00	15.40	13.75
12507HS-13L	18.25	16.65	15.00
12507HS-14L	19.50	17.90	16.25
12507HS-15L	20.75	19.15	17.50
12507HS-20L	27.00	25.40	23.75
12507HS-25L	33.25	31.65	30.00
12507HS-30L	39.50	37.90	36.25

Specification

ITEM	SPEC
Voltage Rating	AC/DC 125V
Current Rating	AC/DC 1A
Operating Temperature	-25°C~+85°C
Contact Resistance	30mΩ MAX
Withstanding Voltage	AC250V/1min
Insulation Resistance	100MΩ MIN
Applicable Wire	AWG #26~#32
Applicable P.C.B	-
Applicable FPC/FFC	-
Solder Height	-
Crimp Tensile Strength	-
UL FILE NO	-

Application Terminal : 12507TS (37 page)