

185-001 (06 Plug) Expanded Beam Fiber Optic Threaded Coupling Plug Connector D38999 Style Shell Size 13

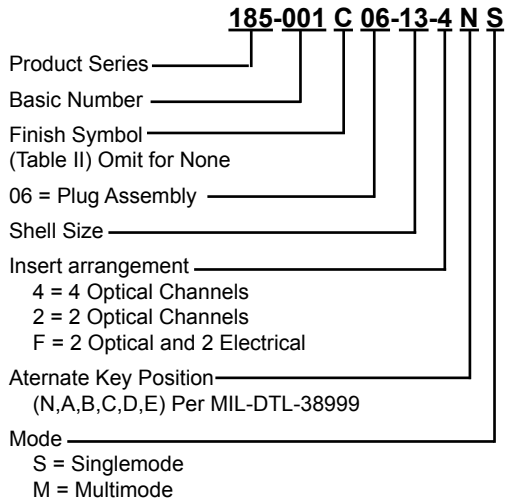
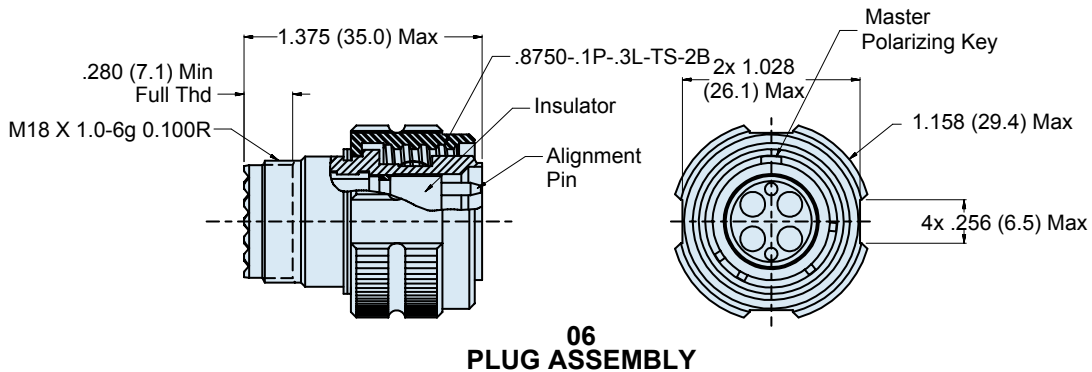

TABLE II: FINISH	
SYM	FINISH
C	Anodize, Black
M	Electroless Nickel Plate
Z1	Stainless Steel, Passivated
NF	Zinc-Nickel/Olive Drab over Electroless Nickel

**PART SUPPLIED ONLY AS
TERMINATED ASSEMBLY**

**CONSULT FACTORY
FOR CABLE DESIGN**



APPLICATION NOTES

1. Assembly identified with Glenair, Inc and P/N, Space Permitting.
2. Glenair 185-001 Connector Features:
 - A. Plug Barrel, Shell, Coupling Nut- AL/BR AB2 or CA104 or DGS1043
 - B. Seal, Gasket- Fluorosilicone Blend
 - C. Thrust Washer & Retaining Ring- Stainless Steel
 - D. Grounding Fingers- Copper Alloy
3. Metric dimensions (mm) are in parentheses.