

PLEASE CHECK WWW.MOLEX.COM FOR LATEST PART INFORMATION

Part Number: [0190170004](#)
Status: **Active**
Description: InsulKrimp™ Quick Disconnect, Female, for 18-22 (0.80-0.35) Wire, Mylar Tape, Tab 2.79mm (.110") x 0.51mm (.020")

Documents:

[Drawing \(PDF\)](#) [RoHS Certificate of Compliance \(PDF\)](#)
[Product Specification PS-19902-008 \(PDF\)](#)

Agency Certification

CSA LR18689
 UL E79133

General

Product Family Quick Disconnects
 Series [19017](#)
 Crimp Quality Equipment Yes
 Product Name InsulKrimp™
 Type Quick Disconnect

Physical

Barrel Type Closed
 Color - Resin Natural
 Flammability 94V-2
 Gender Female
 Glow-Wire Compliant No
 Insulation PVC
 Lock to Mating Part None
 Material - Metal Brass
 Material - Plating Mating Tin
 Material - Plating Termination Tin
 Material - Resin PVC
 Orientation Straight
 Packaging Type Adhesive Tape on Reel
 Plating min: Mating (µin) 160
 Plating min: Mating (µm) 4
 Plating min: Termination (µin) 160
 Plating min: Termination (µm) 4
 Polarized to Mating Part No
 Tab Thickness 0.51mm (.020")
 Tab Width 2.79mm (.110")
 Temperature Range - Operating -50°C to +105°C
 Termination Interface: Style Crimp or Compression
 Wire Insulation Diameter 3.40mm (.134") max.
 Wire Size AWG 18, 20, 22
 Wire Size mm² 0.35 - 0.80

Electrical

Voltage - Maximum 600V

Material Info

Old Part Number AA-2131T

Reference - Drawing Numbers

Product Specification PS-19902-008
 Sales Drawing CD2903

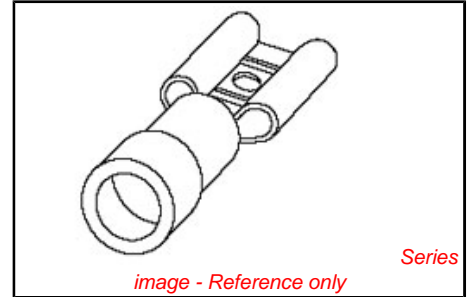

EU RoHS

ELV and RoHS Compliant
REACH SVHC
 Not Reviewed
Halogen-Free Status
 Not Reviewed

China RoHS



Need more information on product environmental compliance?

Email productcompliance@molex.com
 For a multiple part number RoHS Certificate of Compliance, [click here](#)

Please visit the [Contact Us](#) section for any non-product compliance questions.

Search Parts in this Series
[19017Series](#)

Application Tooling | FAQ

Tooling specifications and manuals are found by selecting the products below. Crimp Height Specifications are then contained in the Application Tooling Specification document.

Global

| Description | Product # |
|---|----------------------------|
| Crimp Dies for MTA-100 Tape Applicator used in 3BF Press, MTA-105 Tape Applicator used in TM-2000™ Press, and ATP-301 Air Crimping Press for Mylar Tape Mounted Terminals | 0192880048 |
| Mini-Mac™ Applicator | 0638850800 |

This document was generated on 04/13/2010

PLEASE CHECK WWW.MOLEX.COM FOR LATEST PART INFORMATION

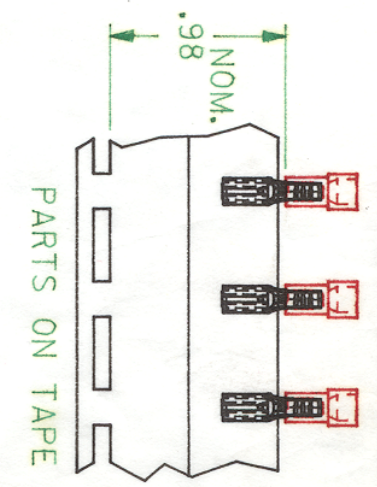
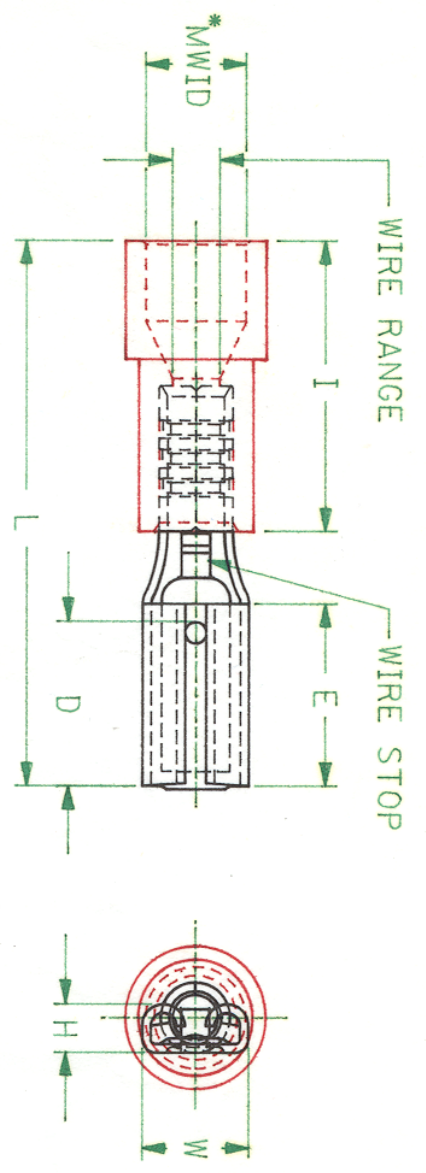

MATERIAL: BRASS
 FINISH: ELECTRO-TIN PLATING
 INSULATION: PVC

*MWID=MAXIMUM WIRE INSULATION DIAMETER

PART NUMBERS ARE FOR LOOSE PIECE TO ORDER PARTS ON TAPE ADD A "T" TO END OF PART NUMBER

| PART NUMBER | INS. COLOR | WIRE AWG | RANGE MM ² | FITS MALE TAB SIZE | STOCK THICK. | "L" MAX. | "I" MAX. | "W" MAX. | "D" ±.01 | "H" ±.01 | "E" NOM. | MWID |
|-------------|------------|----------|-----------------------|--------------------|--------------|----------|----------|----------|----------|----------|----------|------|
| AA-2134 | RED | 22-18 | 0.25-1.3 | .110x.032 | .012 | .78 | .41 | .16 | .210 | .08 | .25 | .13 |
| BB-2135 | BLUE | 16-14 | 1.0-2.6 | .110x.032 | .012 | .78 | .41 | .16 | .210 | .08 | .25 | .14 |
| AA-2131 | RED | 22-18 | 0.25-1.3 | .110x.020 | .012 | .78 | .41 | .16 | .210 | .07 | .25 | .13 |
| BB-2132 | BLUE | 16-14 | 1.0-2.6 | .110x.020 | .012 | .78 | .41 | .16 | .210 | .07 | .25 | .14 |

REVISIONS
 REVISE ONLY ON CAD SYSTEM

INSULKRIMP
 QUICK DISCONNECTS

CUSTOMER DRAWING

DRWG. BY: RCM
 CHK'D. BY:
 APP'D. BY:
 SCALE: NO:NE

ETC INC.
 PINELLAS PARK, FLA. 34665 U.S.A.

PART NO. SEE TABLE
 FILE NAME: CD2903
 THIS DRAWING CONTAINS INFORMATION THAT IS PROPRIETARY TO MOLEX-ETC INC. AND SHOULD NOT BE USED WITHOUT WRITTEN PERMISSION.

DRWG. NO. CD-2903

SHEET NO. DATE: 11/27/90
 DIV. SIZE: A