

**MSK**

M.S.KENNEDY CORP.

# 75 VOLT 20 AMP MOSFET H-BRIDGE PWM MOTOR DRIVER/AMPLIFIER

**4225**

4707 Dey Road Liverpool, N.Y. 13088

(315) 701-6751

**FEATURES:**

- Low RDS(ON) 0.013Ω Typical
- Low Cost Complete H-Bridge
- 20 Amp Capability, 75 Volt Maximum Rating
- Self-contained Smart Lowside/Highside Drive Circuitry
- Internal 45KHz PWM Generation, Shoot-through Protection
- Isolated Case Allows Direct Heatsinking
- Logic Level Disable Input
- Logic Level High Side Enable Input for Special Modulation or Function

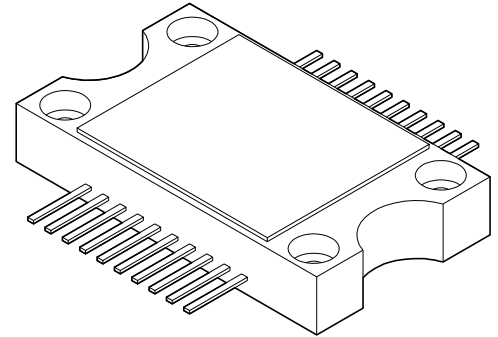
**DESCRIPTION:**

The MSK 4225 is a complete H-Bridge circuit to be used for DC brushed motor control or Class D switchmode amplification. All of the drive/control circuitry for the lowside and highside switches are internal to the circuit. The 45KHz PWM circuitry is internal as well, leaving the user to only provide an analog signal for the motor speed/direction, or audio signal for switchmode audio amplification. The MSK 4225 is constructed in a space efficient plastic power package that can be directly bolted to a heatsink.

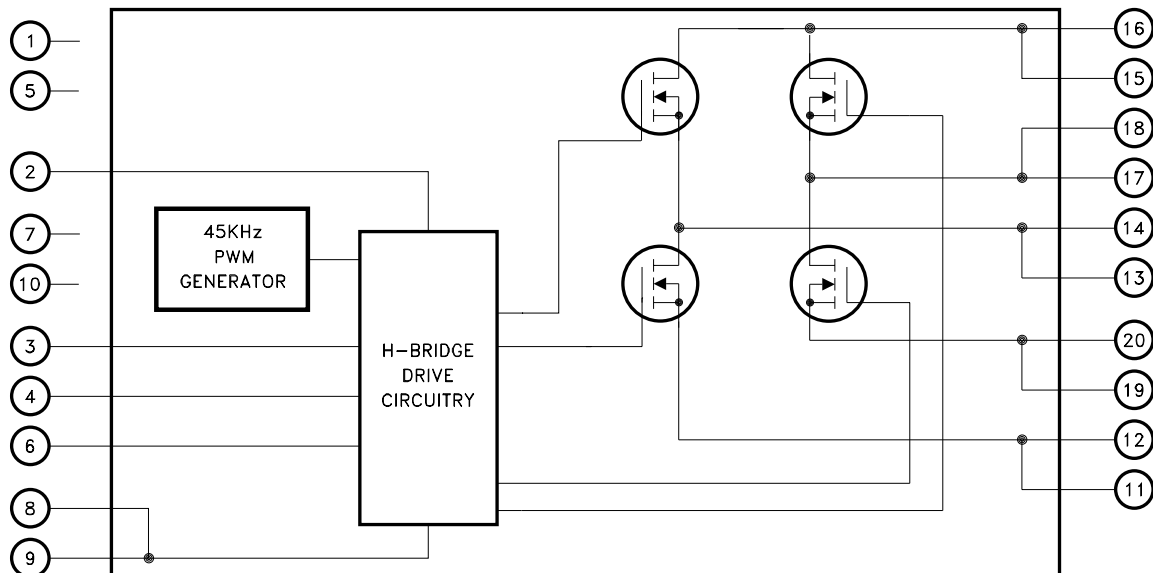
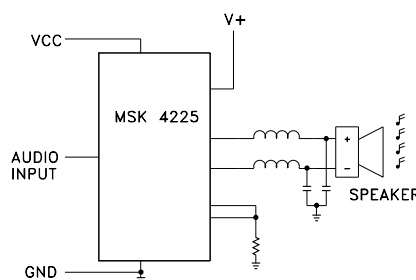
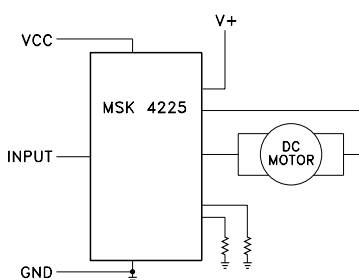
**EQUIVALENT SCHEMATIC****TYPICAL APPLICATIONS****PIN-OUT INFORMATION**

1	NC	20	RSENSE A
2	VCC	19	RSENSE A
3	HEN	18	OUTPUT A
4	DIS	17	OUTPUT A
5	NC	16	V+
6	INPUT	15	V+
7	NC	14	OUTPUT B
8	GND	13	OUTPUT B
9	GND	12	RSENSE B
10	NC	11	RSENSE B

## ABSOLUTE MAXIMUM RATINGS

V <sub>+</sub> High Voltage Supply . . . . .	75V	T <sub>ST</sub> Storage Temperature Range . . . . .	-55°C to +125°C
V <sub>CC</sub> Logic Supply . . . . .	16V	T <sub>LD</sub> Lead Temperature Range . . . . .	300°C (10 Seconds)
I <sub>OUT</sub> Continuous Output Current . . . . .	20A	T <sub>C</sub> Case Operating Temperature	MSK4225 . . . . . -40°C to +85°C
I <sub>PK</sub> Peak Output Current . . . . .	40A	T <sub>J</sub> Junction Temperature . . . . .	+150°C
V <sub>OUT</sub> Output Voltage Range . . . . .	GND -2V min. to V <sub>+</sub> max.		
θ <sub>JC</sub> Thermal Resistance . . . . .	3.0°C/W (Output Switches @ 125°C)		

## ELECTRICAL SPECIFICATIONS

T<sub>C</sub> = +25°C Unless Otherwise Specified

Parameter	Test Conditions ②	MSK 4225			Units
		Min.	Typ.	Max.	
<b>OUTPUT CHARACTERISTICS</b>					
R <sub>DS (ON)</sub> ① ④	Each MOSFET I <sub>D</sub> = 20A	-	-	0.013	Ω
V <sub>DS(ON)</sub> Voltage	Each MOSFET I <sub>D</sub> = 20A ③	-	0.45	0.52	V
Instantaneous Forward Voltage	Each MOSFET I <sub>S</sub> = 20A Intrinsic Diode ③	-	1.0	1.3	V
Reverse Recovery Time ①	Intrinsic Diode	-	-	280	nS
Leakage Current	Each MOSFET V <sub>+</sub> = 70V	-	1.0	25	uA
PWM Frequency		40	45	50	KHz
<b>V<sub>CC</sub> SUPPLY CHARACTERISTICS</b>					
Quiescent Bias Current	Analog Input = 6Vdc	-	43	50	mA
V <sub>CC</sub> Voltage Range ①		9	12	16	V
<b>INPUT SIGNAL CHARACTERISTICS ①</b>					
Analog Input Voltage	Output A,B = 50% Duty Cycle	-	6	-	V
Analog Input Voltage	Output A = 100% Duty Cycle High	-	4	-	V
Analog Input Voltage	Output B = 100% Duty Cycle High	-	8	-	V
<b>LOGIC CONTROL INPUTS ①</b>					
Disable Input	Input Voltage LO	-	-	0.8	V
	Input Voltage HI	2.7	-	-	V
	Input Current (DISABLE = 0V)	-	-	135	uA
HEN Input	Input Voltage LO	-	-	0.8	V
	Input Voltage HI	2.7	-	-	V
	Input Current (HEN = 0V)	-	-	270	uA
<b>SWITCHING CHARACTERISTICS ①</b>					
	R <sub>L</sub> = 100Ω				
Rise Time		-	50	-	nS
Fall Time		-	170	-	nS
Dead Time		-	100	-	nS

### NOTES:

- ① Guaranteed by design but not tested. Typical parameters are representative of actual device performance but are for reference only.
- ② V<sub>CC</sub> = +12V, V<sub>+</sub> = 28V, R<sub>SENSE A,B</sub> = Ground, DIS = 0V, HEN = N/C unless otherwise specified.
- ③ Measured using a 300μS pulse with a 2% Duty Cycle.
- ④ On Resistance is specified for the Internal MOSFET for Thermal Calculations. It does not include the package pin resistance.

## MSK 4225 PIN DESCRIPTIONS

**VCC** - Is the low voltage supply for powering internal logic and drivers for the lowside and highside MOSFETS. The supplies for the highside drivers are derived from this voltage.

**V+** - Is the higher voltage H-bridge supply. The MOSFETS obtain the drive current from this supply pin. The voltage on this pin is limited by the drive IC. The MOSFETS are rated at 75 volts. Proper by-passing to **GND** with sufficient capacitance to suppress any voltage transients, and to ensure removing any drooping during switching, should be done as close to the pins of the module as possible.

**OUTPUT A** - Is the output pin for one half of the bridge. Decreasing the input voltage causes increasing duty cycles at this output.

**OUTPUT B** - Is the output pin for the other half of the bridge. Increasing the input voltage causes increasing duty cycles at this output.

**RSENSE A** - Is the connection for the bottom of the A half bridge. This can have a sense resistor connection to the V+ return ground for current limit sensing, or can be connected directly to ground. The maximum voltage on this pin is  $\pm 2$  volts with respect to GND.

**RSENSE B** - Is the connection for the bottom of the B half bridge. This can have a sense resistor connection to the V+ return ground for current limit sensing, or can be connected directly to ground. The maximum voltage on this pin is  $\pm 2$  volts with respect to GND.

**GND** - Is the return connection for the input logic and Vcc.

**INPUT** - Is an analog input for controlling the PWM pulse width of the bridge. A voltage lower than  $V_{cc}/2$  will produce greater than 50% duty cycle pulses out of OUTPUT A. A voltage higher than  $V_{cc}/2$  will produce greater than 50% duty cycle pulses out of OUTPUT B.

**DISABLE** - Is the connection for disabling all 4 output switches. DISABLE high overrides all other inputs. When taken low, everything functions normally. An internal pullup to Vcc will keep DISABLE high if left unconnected.

**HEN** - Is the connection for enabling the high side output switches. When taken low, HEN overrides other inputs and the high side switches remain off. When HEN is high everything functions normally. An internal pullup to Vcc will keep HEN high if left unconnected.

## TYPICAL SYSTEM OPERATION

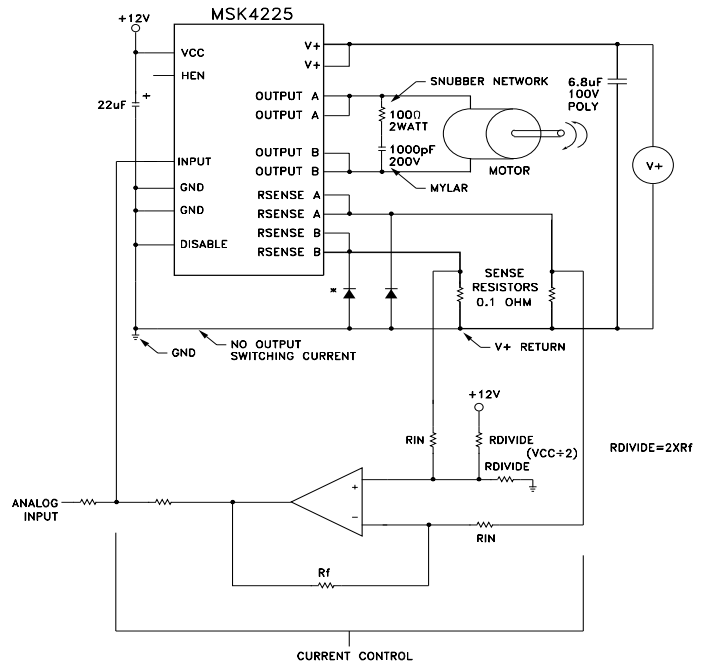

This is a diagram of a typical application of the MSK4225. The design Vcc voltage is +12 volts and should have a good low ESR bypass capacitor such as a tantalum electrolytic. The analog input can be an analog speed control voltage from a potentiometer, other analog circuitry or by microprocessor and a D/A converter. This analog input gets pulled by the current control circuitry in the proper direction to reduce the current flow in the bridge if it gets too high. The gain of the current control amplifier will have to be set to obtain the proper amount of current limiting required by the system.

Current sensing is done in this case by a 0.1 ohm sense resistor to sense current from both legs of the bridge separately. It is important to make the high current traces as big as possible to keep inductance down. The storage capacitor connected to the V+ and the module should be large enough to provide the high energy pulse without the voltage sagging too far. A low ESR ceramic capacitor or large polypropylene capacitor will be required. Mount the capacitor as close to the module as possible. The connection between GND and the V+ return should not be carrying any motor current. The sense resistor signal is common mode filtered as necessary to feed the limiting circuitry for the microprocessor. This application will allow full four quadrant torque control for a closed loop servo system.

A snubber network is usually required, due to the inductance in the power loop. It is important to design the snubber network to suppress any positive spikes above 70V and negative spikes below -2V with respect to ground.

\* There are certain inductive load situations that can possibly cause a momentary shoot-through or cross-conduction condition in the MSK4225. This shoot-through is approximately 100nSec long and can be several amps, depending on the layout and impedance of the bypassing circuit. Most bypassing and current sensing filtering will usually eliminate the effects. However, in the case where it is still present, or the sense resistor trace lengths are long, reverse-biased ultra-fast recovery diodes or power schottky diodes from RSENSE A and RSENSE B to power ground will minimize or eliminate the situation.

## TYPICAL PERFORMANCE CURVES

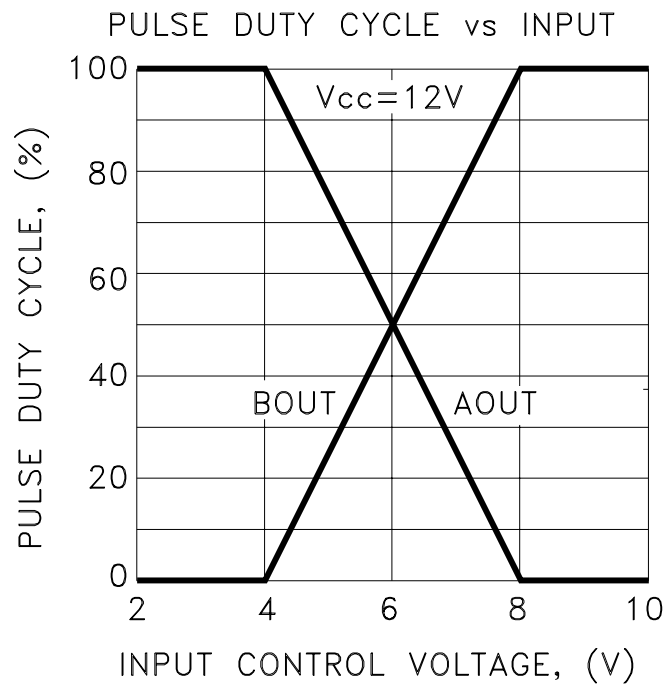
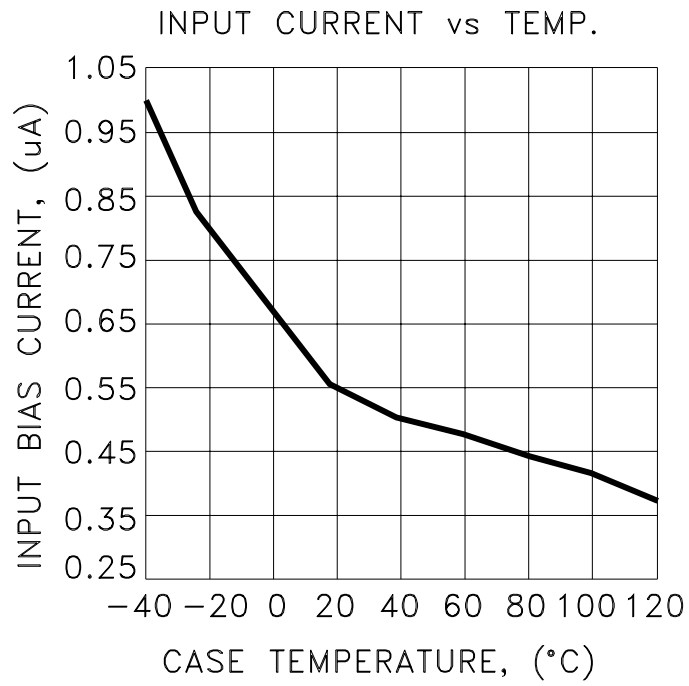

# MECHANICAL SPECIFICATIONS

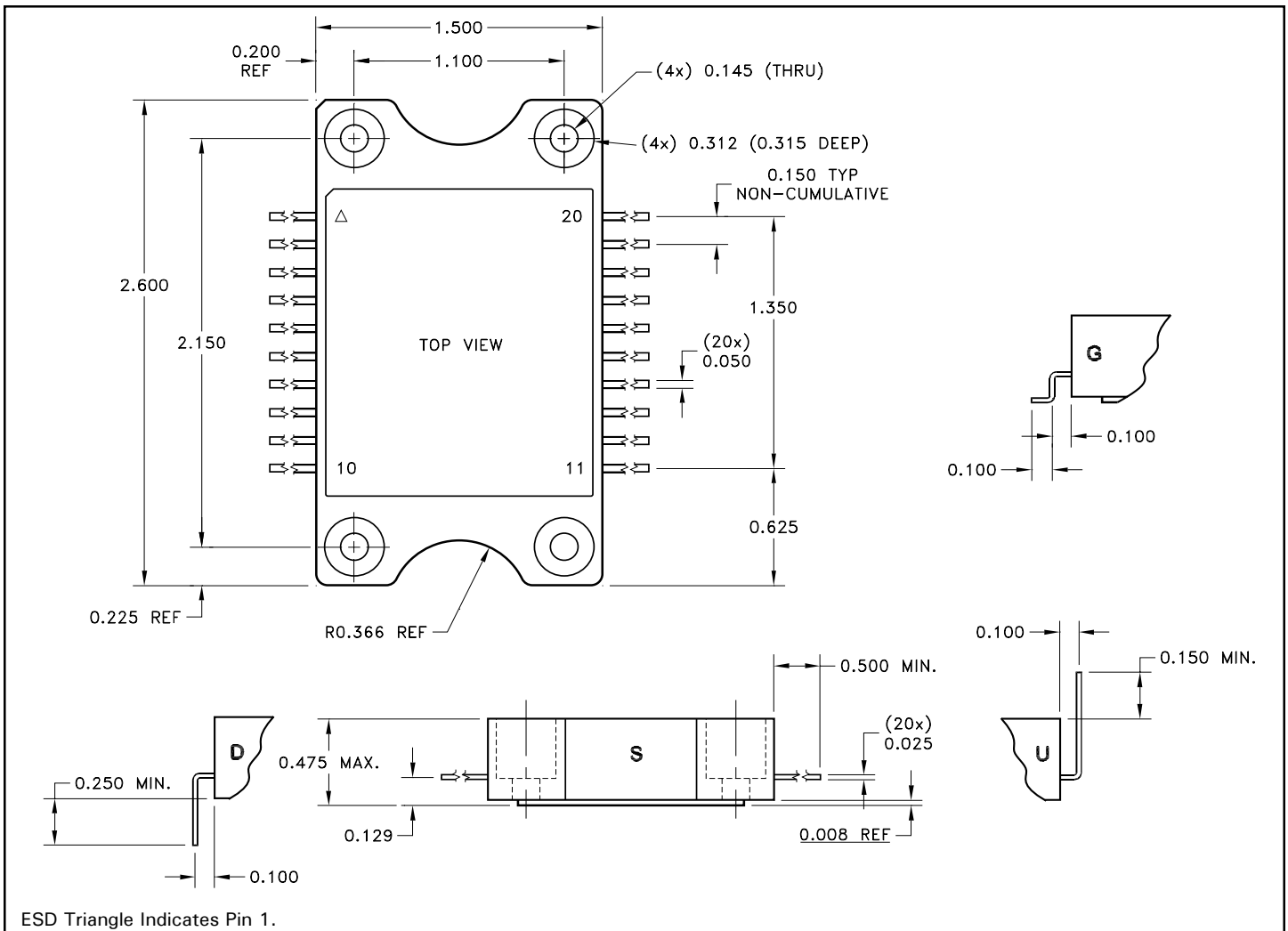

ESD Triangle Indicates Pin 1.

NOTE: ALL DIMENSIONS ARE  $\pm 0.010$  UNLESS OTHERWISE LABELED.

## ORDERING INFORMATION

Part Number	Screening Level	Lead Configuration
MSK4225S	Industrial	Straight
MSK4225D	Industrial	Down
MSK4225U	Industrial	Up
MSK4225G	Industrial	Gull Wing

M.S. Kennedy Corp.  
 4704 Dey Road, Liverpool, New York 13088  
 Phone (315) 701-6751  
 FAX (315) 701-6752  
 www.mskennedy.com

The information contained herein is believed to be accurate at the time of printing. MSK reserves the right to make changes to its products or specifications without notice, however, and assumes no liability for the use of its products. Please visit our website for the most recent revision of this datasheet.