



HIGH SPEED/HIGH VOLTAGE VIDEO DISPLAY DRIVER

1901

M.S.KENNEDY CORP.

4707 Dey Road Liverpool, N.Y. 13088

(315) 701-6751

FEATURES:

- Ultra Fast Rise Time - 2.8nS Typical
- Wide Bandwidth - 225 MHz Typical
- Variable Gain - 0 to 80 V/V
- On Board Reference Output
- 50 VPP Output Voltage Swing
- Blanking Capability
- User Adjustable Brightness and Contrast
- 25,000 V/ μ Sec Slew Rate
- Available to DSCC SMD 5962-9324601HX

MIL-PRF-38534 QUALIFIED

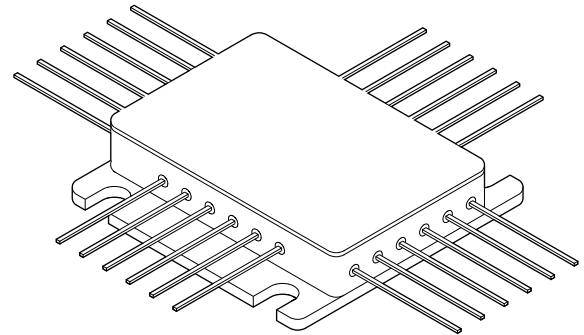

DESCRIPTION:

The MSK 1901 is a high performance, high voltage, variable gain video amplifier. The hybrid's open collector output is capable of directly driving a high resolution video display. The MSK 1901 features differential inputs and a linearly adjustable gain stage with an output offset adjustment which allows it to be a versatile performer well suited for many applications. A TTL level blanking input is available to set the output to a predetermined black level independent of signal output. The MSK 1901 is packaged in a hermetically sealed 24 pin quad flat pack with mounting flanges that can be conveniently connected to a heat sink.

EQUIVALENT SCHEMATIC

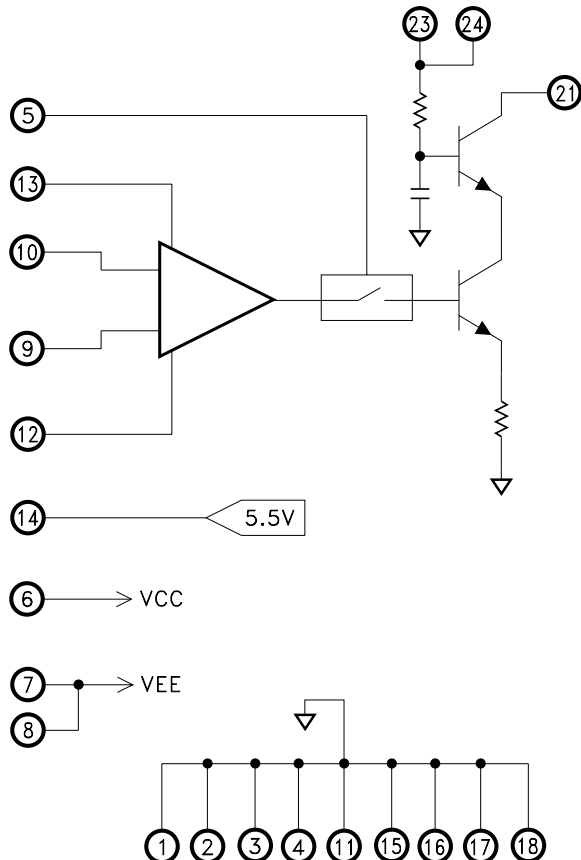

TYPICAL APPLICATIONS

- High Resolution Mono-Chrome Displays
- High Resolution RGB Displays
- High Speed, High Voltage Amplification for ATE

PIN-OUT INFORMATION

1	Ground	13	V _{OFF}
2	Ground	14	V _{REF}
3	Ground	15	Ground
4	Ground	16	Ground
5	Blank	17	Ground
6	V _{CC}	18	Ground
7	V _{EE}	19	NC
8	V _{EE}	20	NC
9	-Input	21	Output
10	+ Input	22	NC
11	Ground	23	V _{CB}
12	V _{GAIN}	24	V _{CB}

ABSOLUTE MAXIMUM RATINGS

+V _{HV}	High Voltage Supply (WRT V _{CB})	+65V
+V _{CC}	Positive Supply Voltage	+12V
-V _{EE}	Negative Supply Voltage	-12V
V _{CB}	Common Base Supply Voltage	+20V
V _{ID}	Differential Input Voltage	2V
V _{GAIN}	Gain Adjust Input Voltage	-0.6V to +6V
V _{OFF}	Offset Adjust Input Voltage	-0.6V to +6V
V _{BLANK}	Blank Input Voltage	-0.6V to +6V
I _{REF}	Reference Output Current	5mA

T _{ST}	Storage Temperature Range	-65°C to +150°C
T _{LD}	Lead Temperature Range (Solder 10 Seconds)	+300°C
T _J	Junction Temperature	+175°C
P _D	Total Power Dissipation (T _C = 25°C)	13W
T _C	Case Operating Temperature Range (MSK 1901B/E)	-55°C to +125°C
	(MSK1901)	-40°C to +85°C

ELECTRICAL SPECIFICATIONS

Parameter	Test Conditions ^①	Group A Subgroup	MSK1901B			Units
			Min.	Typ.	Max.	
STATIC						
Quiescent Current	V _{CM} = 0V @ +10V	1,2,3	-	55	70	mA
	V _{CM} = 0V @ -10.5V	1,2,3	-	75	100	mA
High Voltage Supply (WRT V _{CB}) ^②	T _C ≤ 125°C	-	20	60	65	V
Thermal Resistance ^②	Junction To Case	-	-	5	7	°C/W
INPUT						
Input Bias Current	V _{CM} = 0V	1	-	±1	±50	μA
		2,3	-	±5	±250	μA
Blank Input Current	V _{BLANK} = 0.4V	1	-	500	600	μA
	V _{BLANK} = 2.4V	1	-	300	400	μA
Offset Adjust Input Current	V _{OFF} = 1V	1	-	2	10	μA
Gain Adjust Input Current	V _{GAIN} = 5V	1	-	2	10	μA
Blank Input Pulse Width ^②	Normal Operation	-	30	-	-	nS
Common Mode Rejection Ratio	V _{CM} = ±0.5V F = 10Hz	-	-	40	-	dB
Input Impedance ^②	Either Input F = DC	-	10	20	-	KΩ
Input Capacitance	Either Input	-	-	2	-	pF
Blank Mode Input Rejection ΔmA ^②	V _{BLANK} = 2.4V V _{IN} = 0.3V	-	-	-	±2	mA
Gain Adjust Rejection ΔmA ^②	ΔV _{GAIN} = 5V	-	-	-	±10	mA
Power Supply Rejection Ratio ^②	+V _{CC} and -V _{CC} = Nom ±5%	-	25	30	-	dB
OUTPUT						
Reference Output Voltage	I _{OUT} < 2mA	1,2,3	5.2	5.5	5.8	V
Output Current Blank Mode	V _{BLANK} = 2.4V V _{OFF} = 1V V _{GAIN} = 0V	1,2,3	-2	0	2	mA
Output Current Min Offset	V _{OFF} = 0V V _{GAIN} = 4V	1,2,3	0.5	10	25	mA
Output Current Max Offset	V _{OFF} = 5V V _{GAIN} = 0V	1,2,3	80	100	120	mA
Transconductance	V _{IN} = 0.6V F = 10KHz V _{GAIN} = 5V Both Inputs	4	395	500	605	mS
Common Base Current	V _{CM} = 0V	1,2,3	-	30	40	mA
Bandwidth ^②	V _{OFF} = 0V R _L = 50Ω	-	200	225	-	MHz
Transition Times ^③	V _{IN} = 0.6V V _{GAIN} = 4V T _R = T _F < 1nS V _{OFF} = 1V	4	-	2.8	4.5	nS
Linearity Error ^②	V _{GAIN} = 1V V _{OFF} = 1V V _{CM} = 0.5V	-	-	-	±2	%GS
Gain Linearity ^②	V _{OFF} = 1V V _{IN} = 0.2V V _{CM} = 0.5V	-	-	-	±2	%
Thermal Distortion ^②	-	-	-	-	±2	%GS

NOTES:

- ① +V_{CC} = +10V, -V_{EE} = -10.5V, +V_{HV} = +70V, V_{CB} = +10V, V_{BLANK} = 0.4V, C_L = 6pF, R_L = 200Ω, V_{GAIN} = V_{OFF} = ±V_{IN} = 0V unless otherwise specified.
- ② Guaranteed by design but not tested. Typical parameters are representative of actual device performance but are for reference only.
- ③ Much faster rise times are obtainable without using test sockets. In addition, a peaking network may be used to improve overall bandwidth.
- ④ Industrial grade and "E" suffix devices shall be tested to subgroups 1 and 4 unless otherwise specified.
- ⑤ Military grade devices ("B" suffix) shall be 100% tested to subgroups 1,2,3 and 4.
- ⑥ Subgroups 5 and 6 testing available upon request.
- ⑦ Subgroup 1,4 T_C = +25°C
Subgroup 2,5 T_C = +125°C
Subgroup 3,6 T_A = -55°C

APPLICATION NOTES

INITIAL SETUP

It is important to set the V_{OFF} and V_{GAIN} inputs to obtain balanced rise/fall times during initial setup of the MSK 1901. If the quiescent current level of V_{OFF} is set too low, it will slow the rise time and limit the bandwidth of the MSK 1901.

VIDEO INPUTS

The analog inputs ($\pm V_{IN}$) are designed to accept RS343 signals, $\pm 0.714V_{PP}$, and will operate properly with a common mode range of $\pm 0.5V$ with respect to ground. Therefore, it is recommended that the input signal be limited to $\pm 1.3V$ with respect to ground, (signal + common mode). Although large offsets of $\pm 2V$ (with respect to ground, signal included) can be tolerated without damage to the hybrid, output linearity suffers and therefore it is not recommended.

V_{GAIN}

V_{GAIN} is the DC gain (contrast) control which varies the gain from 0 to 80V/V. The internal reference (V_{REF}) is available to drive this input. Normally a 5K potentiometer is connected between V_{REF} and GND is used to vary the gain, but any 0-5V external DC source may be used with some additional degradation of gain stability over temperature. A 0.1 μ F capacitor should be connected from the V_{GAIN} pin to ground to improve stability.

The gain equation for the MSK 1901 is:

$$\begin{aligned} V_{LRS}-V_O &= V_{IN} \times G_M \times R_L \\ &= V_{IN} (V_{GAIN} \times 0.08) R_L \end{aligned}$$

The overall gain of the MSK 1901 may vary by $\pm 20\%$ due to process variations of the internal components. Temperature variations also effect gain, $< 150\text{ppm}/^\circ\text{C}$. If more than one MSK 1901 is used in a system, steps should be taken to make them track thermally (i.e. a common heat sink). This will reduce any mismatches due to varying temperatures.

V_{OFF}

V_{OFF} is the output offset (brightness) control used to set the output quiescent current and consequently the DC output voltage (black level). Output quiescent current adjustment range is from several μA to 100mA nominal (80 to 130mA actual). Normally a 5K potentiometer is connected between V_{REF} and GND to this input, but any 0-5V external DC source may be used. A 0.1 μ F capacitor should be connected from this pin to signal ground to improve the amplifier's stability.

BLACK LEVEL

The voltage developed across the external load resistor with a 0V video input to the MSK 1901 is the black level. This voltage may be changed by adjusting the load resistor or by varying the output quiescent current of the MSK 1901 as described in V_{OFF} above. The black level could also be affected by the V_{GAIN} control voltage if the video input has a DC component. AC coupling of the video input will prevent this phenomenon from occurring.

BLANKING

The blank input is a TTL active high input. When active it will disable the video input of the MSK 1901 and allow the output to rise to approximately V_{LRS} . If the blank input rises above 3V some interaction between V_{OFF} and BLANK level may occur. The BLANK input is independent of the input signal and must be tied "low" to activate the amplifier if the blanking function is not used.

V_{REF} OUTPUT

V_{REF} is a buffered zener reference with a nominal output voltage of 5.5V $\pm 5\%$ which can source up to 4mA. It is available for use in adjusting the offset and gain. If multiple amplifiers are used for RGB amplification, they should all share the same V_{REF} pin from one of the hybrids. The V_{REF} pin should be buffered with a unity gain precise amplifier when driving three amplifiers for RGB applications.

V_{CB}

The V_{CB} input is the base connection to the output stage consisting of a common base, high voltage stage and a high speed, low voltage current amplifier in a cascode arrangement. This input requires a very stable 10V DC nominal voltage. Any AC signals at this point will be amplified and reflected in the output. The PSRR of the output stage is directly related to the stability of this V_{CB} voltage.

VIDEO OUTPUT

The video output voltage is obtained from the open collector of a cascode circuit designed to operate with a nominal output supply (V_{LRS}) of +70V. V_{LRS} must be greater than the applied V_{CB} voltage, but less than $V_{CB} + 65V$. The output of MSK 1901 will drive loads up to 250mA when proper heat sinking is used.

OUTPUT CONNECTIONS

In applying the MSK 1901 in a system, two challenges present themselves. The first challenge is to minimize any stray capacitance from the output pin to ground. Since the output connection is extremely susceptible to capacitance loading, the elimination of ground planes adjacent to the output and resistive load are important or the rise and fall times will be limited. Keep output connections as short as possible and insure that any ground plane is at least one inch from the output signal.

The second challenge is to provide a very low impedance connection between two sets of ground pins (1, 2, 3, 4 and 15, 16, 17, 18). If mounting permits, the best solution is to run a board ground track under the MSK 1901 connecting the adjacent ground pins. However, the standard practice of heat sinking the MSK 1901 directly to the CRT chassis usually precludes this. A cut-out is usually provided in the PC board where the MSK 1901 is surface mounted on the opposite side from the other components. Two suggestions for this surface mounting technique to improve performance are directed at functionality or speed.

A functional solution is to run a ground trace on the output pin side of the hybrid on the back side of the PC board. The trace should be 0.1 to 0.2 inch necking down to 0.1 inch as it perpendicularly crosses the output trace on the other side of the board. This results in added capacitance of only 0.1 to 0.4 pF.

A high speed solution is to have the ground cross the input pin side of the hybrid. To counter the signal ground disruption, the signal ground (pin 11) is internally connected to the (15, 16, 17, 18) grounds. Use as broad a ground trace as possible to improve stability.

A third suggestion is to buffer the MSK 1901 using a differential follower stage. This configuration as shown in Figure 1 below allows an easier layout which minimizes stray capacitance. The rise time is essentially limited by the capacitance of the output transistor and that of Q1 and Q2.

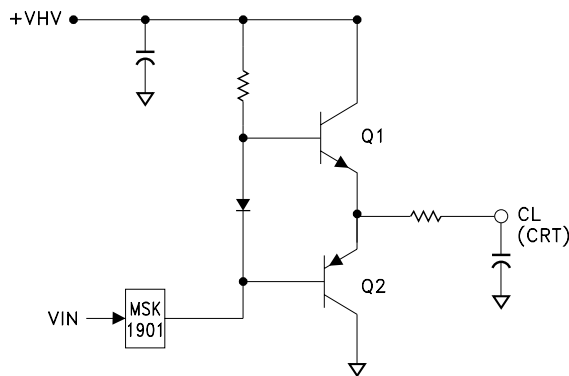

Figure 1

POWER SUPPLIES

A +10V and a -10.5V power supply are required for proper operation. These supplies can be set at $\pm 12V$ for convenience but this will increase the internal power dissipation and package case temperature. V_{LRS} can be any voltage above V_{CB} but not greater than $V_{CB} + 65V$. To achieve maximum performance good high frequency grounding practices and PC board layout are essential.

Proper power supply decoupling is also essential for stability and good video performance. Place bypass capacitors as close to power supply pins as possible. Refer to the typical connection circuit for recommended connections.

POWER SUPPLY SEQUENCING

Power supply sequencing is necessary to avoid internal latch-up of the hybrid. External diodes should be placed (anode to cathode) from V_{EE} to GND, from GND to V_{CC} and from V_{CC} to V_{LRS} . If power supply sequencing is not possible, all supplies should be applied to the hybrid within 5 mS of each other.

POWER DISSIPATION

The MSK 1901 power dissipation will vary depending on load requirements and speed. The quad flat pack of the hybrid is designed to provide a low thermal resistance path from the hybrid circuit to an external heat sink. Mounting flanges provide for excellent mechanical and thermal attachment of the package to the heat sink. In addition, the package is electrically isolated so that mounting insulators are not needed and the heat sink can be at any convenient potential. Refer to the following table for typical power levels for selected video conditions:

POWER DISSIPATION TABLE

($T_C = 25^\circ C$, $V_{LRS} = 70V$, $R_L = 200\Omega$)

$V_O - V_{BLACK}$	Duty Cycle %	IC P_D Watts	P_{LOAD} Watts	TOTAL P_D Watts
0	0	1.6	0	1.6
35	100	7.8	6.1	13.9
35	80	6.5	4.9	11.4
50	80	5.6	10	15.6

When using multiple MSK 1901's, attach all devices to a common heat sink (e.g. in a RGB system). This allows close thermal tracking between hybrids and improves color balance with varying input drive and ambient temperature conditions. Common thermal tracking of the devices reduces timing and other errors found in RGB systems.

TYPICAL CONNECTION CIRCUIT

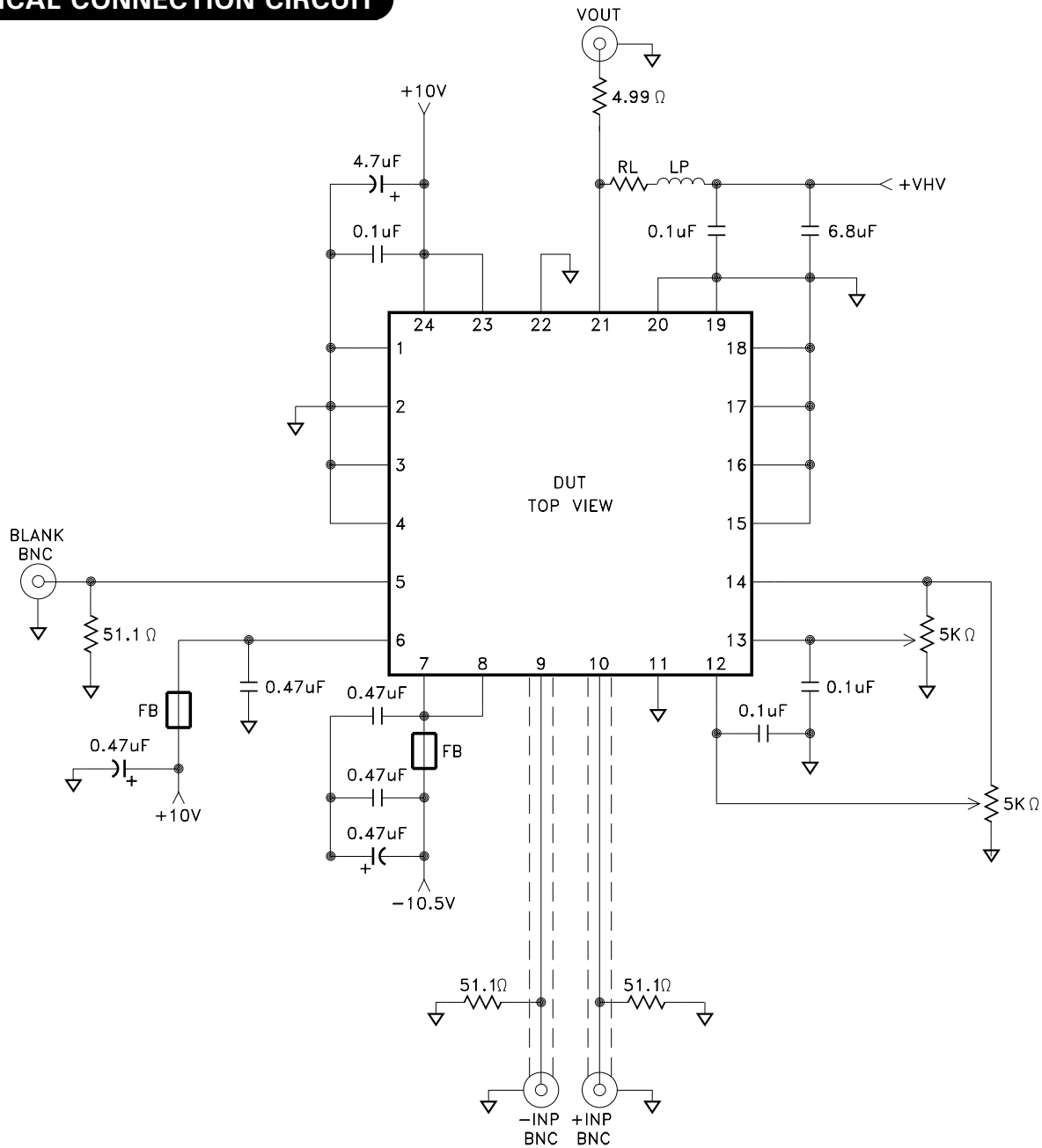

The connection circuit shown above is for the MSK 1901. The R_L and L_P are external components and must not be located near ground planes if possible. A high quality resistor such as Bradford Electronics P/N FP10-200 is required for optimum response times. Use an inductor with a high self-resonant frequency that can withstand the currents required for the application. The ferrite beads should be located as close to the DUT as possible. Fare-Rite Corporation P/N 2743001111 beads work well for most applications. For additional applications information, please contact MSK. Evaluation amplifiers with test boards are readily available upon request.

NOTES:

MECHANICAL SPECIFICATIONS

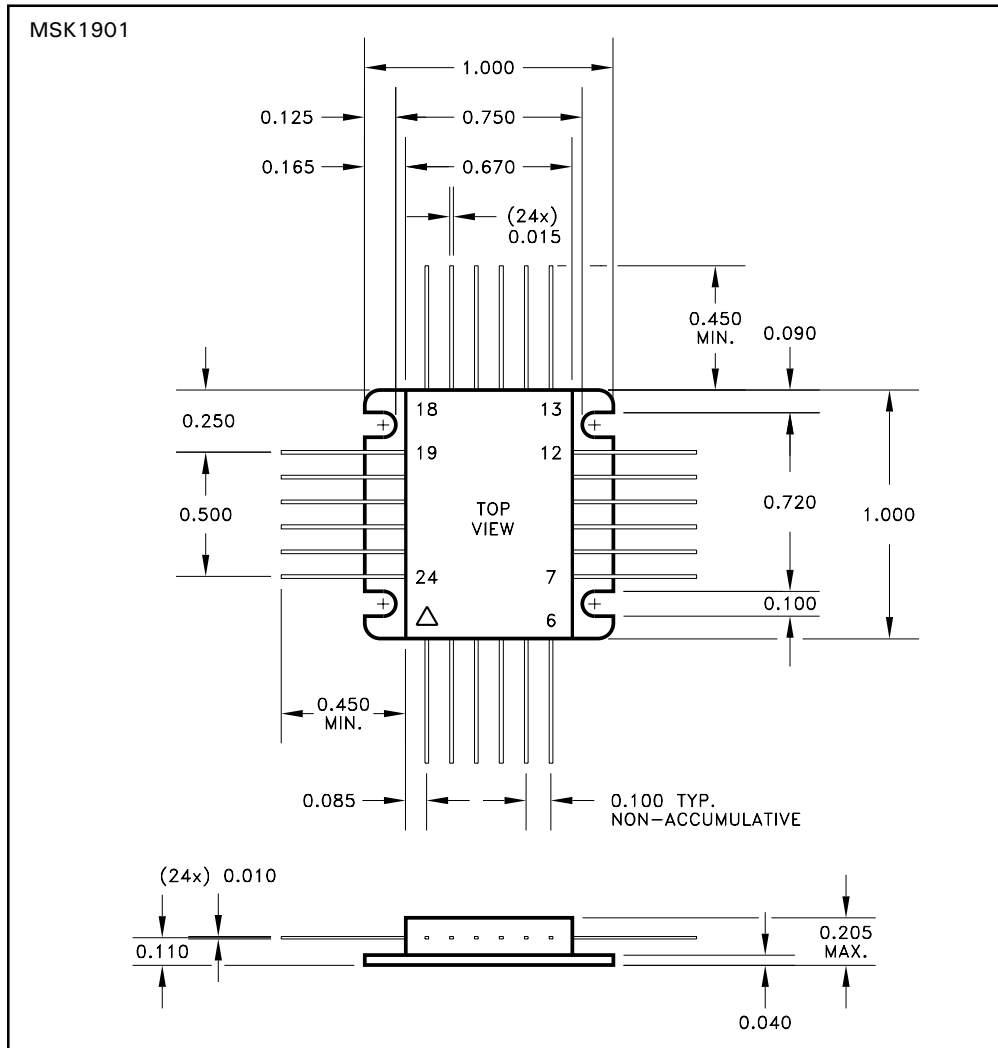

ESD TRIANGLE INDICATES PIN 1.

ALL DIMENSIONS ARE ± 0.010 INCHES UNLESS OTHERWISE LABELED.

ORDERING INFORMATION

Part Number	Screening Level
MSK1901	Industrial
MSK1901B	Military-Mil-PRF-38534 Class H
MSK1901E	Extended Reliability
5962-9324601HX	DSCC-SMD

M.S. Kennedy Corp.

4707 Dey Road, Liverpool, New York 13088

Phone (315) 701-6751

FAX (315) 701-6752

www.mskennedy.com

The information contained herein is believed to be accurate at the time of printing. MSK reserves the right to make changes to its products or specifications without notice, however, and assumes no liability for the use of its products. Please visit our website for the most recent revision of this datasheet.