

**MSK**

M. S. KENNEDY CORP.

**HIGH POWER  
CLASS C AMPLIFIER****161**

4707 Dey Road Liverpool, N.Y. 13088

(315) 701-6751

**MIL-PRF-38534 QUALIFIED****FEATURES:**

- High Output Current
- Wide Supply Range
- Low Cost Class "C" Output Stage
- Wide Common Mode Range
- Low Quiescent Current
- Electrically Isolated Case
- Replaces PA61

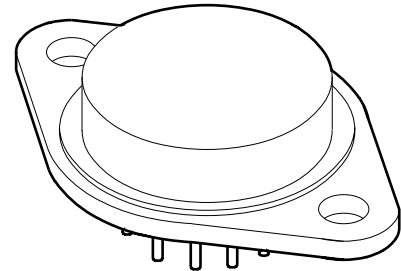
**MSK 161****DESCRIPTION:**

The MSK 161 is a high output current operational amplifier designed to drive resistive or reactive loads. The Class "C" output stage is protected by a user programmable current limit scheme. The MSK 161 is designed to be a low cost solution for low frequency applications where crossover distortion is not critical. The MSK 161 can supply  $\pm 10$  amps of output current within its safe operating range and boasts a 16 KHz power bandwidth. A low junction to case thermal resistance of only  $1.2^{\circ}\text{C}/\text{W}$  for the output devices keeps junction temperatures low when driving large load currents.

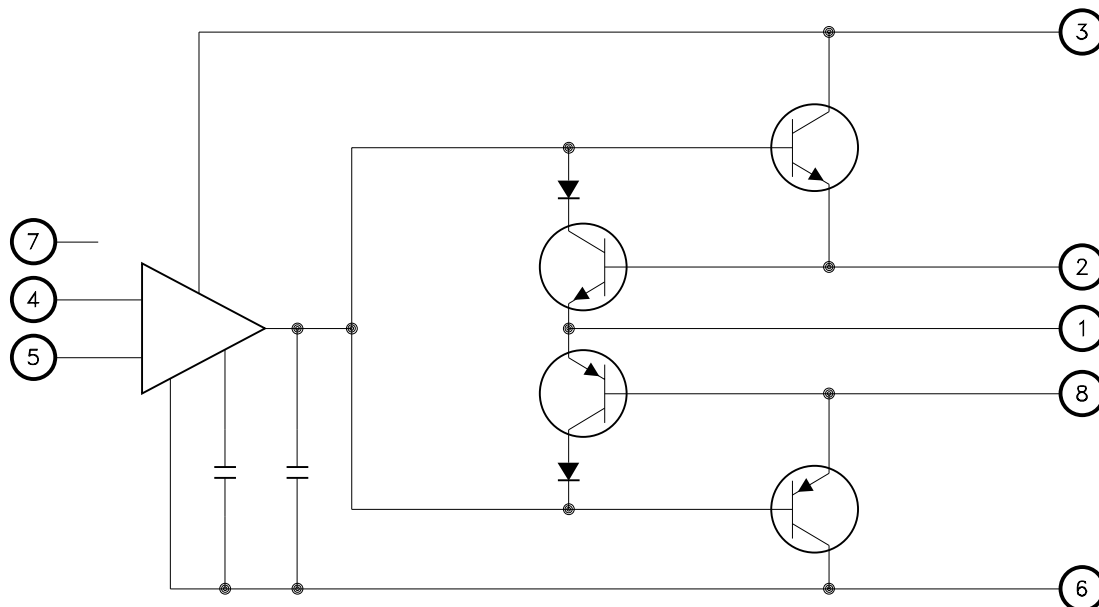
**EQUIVALENT SCHEMATIC****TYPICAL APPLICATIONS**

- Programmable Power Supply
- Valve and Actuator Control
- Motor/Syncro Driver
- AC or DC Power Regulator

**PIN-OUT INFORMATION**

- |                          |                          |
|--------------------------|--------------------------|
| 1 Output                 | 8 Negative Current Limit |
| 2 Positive Current Limit | 7 NC                     |
| 3 Positive Power Supply  | 6 Negative Power Supply  |
| 4 Non-Inverting Input    | 5 Inverting Input        |

## ABSOLUTE MAXIMUM RATINGS

$\pm V_{CC}$	Supply Voltage . . . . .	$\pm 45V$
$I_{OUT}$	Output Current . . . . .	$\pm 10A$
$V_{IN}$	Differential Input Voltage . . . . .	$\pm V_{CC} - 3V$
$T_C$	Case Operating Temperature Range (MSK 161B/E) . . . . .	$-55^{\circ}C$ to $+125^{\circ}C$
	(MSK 161) . . . . .	$-40^{\circ}C$ to $+85^{\circ}C$

$T_{ST}$	Storage Temperature Range . . . . .	$-65^{\circ}C$ to $+150^{\circ}C$
$T_{LD}$	Lead Temperature Range . . . . . (10 Seconds)	$300^{\circ}C$
$T_J$	Junction Temperature . . . . .	$175^{\circ}C$

## ELECTRICAL SPECIFICATIONS

$\pm V_{CC} = 36VDC$  Unless Otherwise Specified

Parameter	Test Conditions	Group A Subgroup	MSK 161B/E			MSK 161			Units
			Min.	Typ.	Max.	Min.	Typ.	Max.	
<b>STATIC</b>									
Supply Voltage Range ②		-	$\pm 10.0$	-	$\pm 45.0$	$\pm 10.0$	-	$\pm 45.0$	V
Quiescent Current	$V_{IN} = 0V$	1	-	$\pm 3.0$	$\pm 10.0$	-	$\pm 3.0$	$\pm 10.0$	mA
	$A_v = -10V/V$	2,3	-	-	$\pm 15.0$	-	-	-	mA
Thermal Resistance ②	$F < 60Hz$ Junction to Case	-	-	1.2	1.8	-	1.2	1.8	$^{\circ}C/W$
<b>INPUT</b>									
Input Offset Voltage	$V_{IN} = 0V$ $A_v = 10V/V$	1	-	$\pm 2.0$	$\pm 6.0$	-	$\pm 2.0$	$\pm 10$	mV
	Bal. Pins = NC	2,3	-	$\pm 10.0$	$\pm 15.0$	-	-	-	mV
Input Bias Current	$V_{CM} = 0V$	1	-	$\pm 12.0$	$\pm 30.0$	-	$\pm 12.0$	$\pm 50$	nA
	Either Input	2,3	-	-	$\pm 115.0$	-	-	-	nA
Input Offset Current	$V_{CM} = 0V$	1	-	$\pm 12.0$	$\pm 30.0$	-	$\pm 12.0$	$\pm 50$	nA
		2,3	-	-	$\pm 115.0$	-	-	-	nA
Input Impedance ②	$F = DC$	-	-	200	-	-	200	-	$M\Omega$
Common Mode Range ②		-	-	$\pm V_S - 3$	-	-	$\pm V_S - 3$	-	V
Common Mode Rejection Ratio ②	$F = 1KHz$ $V_{CM} = \pm 10V$	-	74	100	-	74	100	-	dB
<b>OUTPUT</b>									
Output Voltage Swing	$V_{CC} = \pm 45V$ $R_L = 1K\Omega$ $A_v = -10V/V$	4	$\pm 40$	-	-	$\pm 40$	-	-	V
Output Current, Peak	$R_{CL} = 0\Omega$ $A_v = -10V/V$ $T_J < 175^{\circ}C$	4	$\pm 9.0$	$\pm 10.0$	-	$\pm 9.0$	10.0	-	A
Settling Time ① ②	0.1% 2V step	-	-	2.0	-	-	2.0	-	$\mu S$
<b>TRANSFER CHARACTERISTICS</b>									
Slew Rate	$V_{OUT} = \pm 25V$ $R_L = 1K\Omega$ $A_v = -10V/V$	4	1.0	2.5	-	1.0	2.5	-	$V/\mu S$
Open Loop Voltage Gain ②	$V_O = \pm 25V$ $R_L = 1K\Omega$ $F = 10Hz$	4	96	100	-	96	100	-	dB
Gain Bandwidth Product ②	$R_L = 1K\Omega$ $F = 1MHz$	-	-	1	-	-	1	-	MHz

### NOTES:

- ①  $A_v = -1$ , measured in false summing junction circuit.
- ② Guaranteed by design but not tested. Typical parameters are representative of actual device performance but are for reference only.
- ③ Industrial grade and "E" suffix devices shall be tested to subgroups 1 and 4 unless otherwise specified.
- ④ Military grade devices ("B" suffix) shall be 100% tested to subgroups 1,2,3 and 4.
- ⑤ Subgroups 5 and 6 testing available upon request.
- ⑥ Subgroup 1,4  $T_A = T_C = +25^{\circ}C$   
 Subgroup 2,5  $T_A = T_C = +125^{\circ}C$   
 Subgroup 3,6  $T_A = T_C = -55^{\circ}C$

## APPLICATION NOTES

### HEAT SINKING

To determine if a heat sink is necessary for your application and if so, what type, refer to the thermal model and governing equation below.

#### Thermal Model:

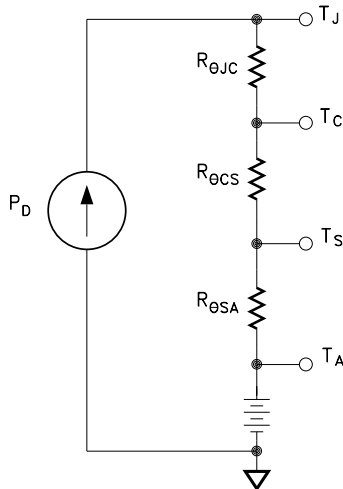

#### Governing Equation:

$$T_J = P_D \times (R_{\theta JC} + R_{\theta CS} + R_{\theta SA}) + T_A$$

Where

$T_J$  = Junction Temperature

$P_D$  = Total Power Dissipation

$R_{\theta JC}$  = Junction to Case Thermal Resistance

$R_{\theta CS}$  = Case to Heat Sink Thermal Resistance

$R_{\theta SA}$  = Heat Sink to Ambient Thermal Resistance

$T_C$  = Case Temperature

$T_A$  = Ambient Temperature

$T_S$  = Sink Temperature

#### Example:

In our example the amplifier application requires the output to drive a 20 volt peak sine wave across a 400Ω load for 50mA of peak output current. For a worst case analysis we will treat the 50mA peak output current as a D.C. output current. The power supplies are ±40 VDC.

##### 1.) Find Power Dissipation

$$\begin{aligned} P_D &= [(quiescent\ current) \times (V_s - (V_s))] + [(+V_s - V_o) \times I_{out}] \\ &= (3.0mA) \times (80V) + (20V) \times (1A) \\ &= 0.24W + 20W \\ &= 20.24W \end{aligned}$$

##### 2.) For conservative design, set $T_J = +125^\circ C$

##### 3.) For this example, worst case $T_A = +50^\circ C$

##### 4.) $R_{\theta JC} = 1.8^\circ C/W$ from MSK 161 Data Sheet

##### 5.) $R_{\theta CS} = 0.15^\circ C/W$ for most thermal greases

##### 6.) Rearrange governing equation to solve for $R_{\theta SA}$

$$\begin{aligned} R_{\theta SA} &= ((T_J - T_A) / P_D) - (R_{\theta JC}) - (R_{\theta CS}) \\ &= ((125^\circ C - 50^\circ C) / 20.24W) - (1.8^\circ C/W) - (0.15^\circ C/W) \\ &= 1.76^\circ C/W \end{aligned}$$

The heat sink in this example must have a thermal resistance of no more than 1.76°C/W to maintain a junction temperature of no more than +125°C.

### CURRENT LIMIT

The MSK 161 has an on-board current limit scheme designed to shut off the output drivers anytime output current exceeds a predetermined limit. The following formula may be used to determine the value of current limit resistance necessary to establish the desired current limit.

$$R_{CL} = (\text{OHMs}) = (0.65 \text{ volts/current limit in amps}) - 0.01\text{OHM}$$

The 0.01 ohm term takes into account any wire bond and lead resistance. Since the 0.65 volt term is obtained from the base emitter voltage drop of a bipolar transistor: the equation only holds true for operation at +25°C case temperature. The effect that temperature has on current limit may be seen on the Current Limit vs. Case Temperature Curve in the Typical Performance Curves.

### CURRENT LIMIT CONNECTION

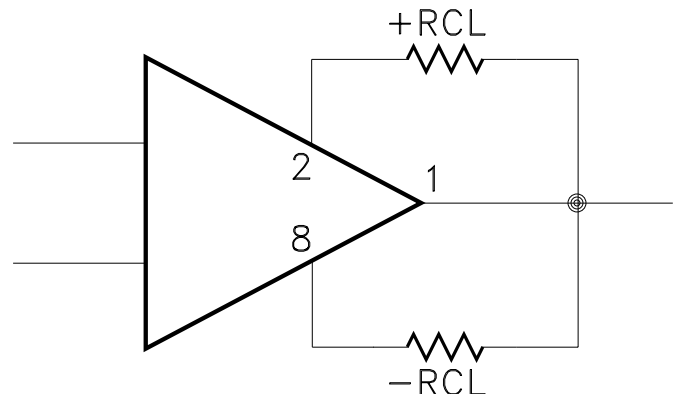

### POWER SUPPLY BYPASSING

Both the negative and the positive power supplies must be effectively decoupled with a high and low frequency bypass circuit to avoid power supply induced oscillation. An effective decoupling scheme consists of a 0.1 microfarad ceramic capacitor in parallel with a 4.7 microfarad tantalum capacitor from each power supply pin to ground. It is also a good practice with very high power op-amps, such as the MSK 161, to place a 30-50 microfarad non-electrolytic capacitor with a low effective series resistance in parallel with the other two power supply decoupling capacitors. This capacitor will eliminate any peak output voltage clipping which may occur due to poor power supply load regulation. All power supply decoupling capacitors should be placed as close to the package power supply pins as possible (pins 7 and 12).

# TYPICAL PERFORMANCE CURVES

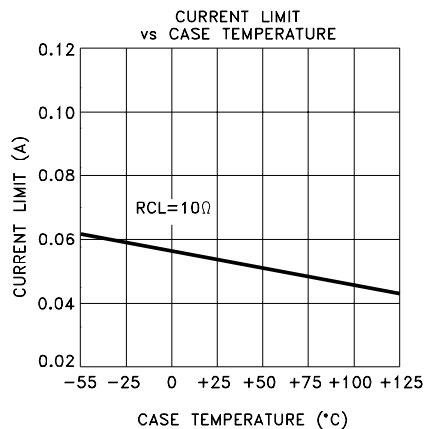
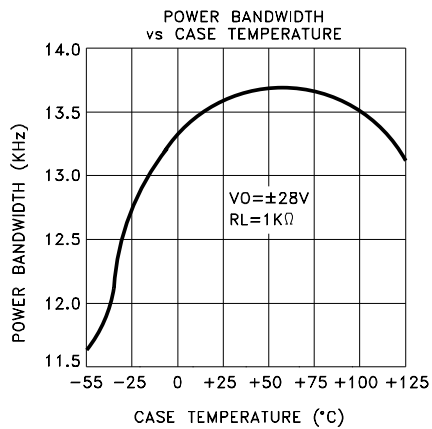
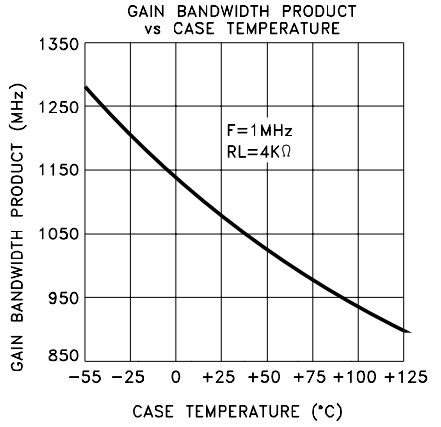
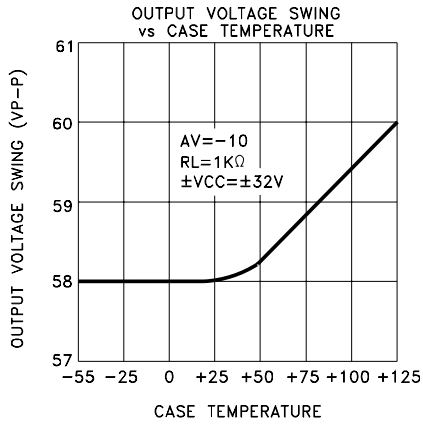
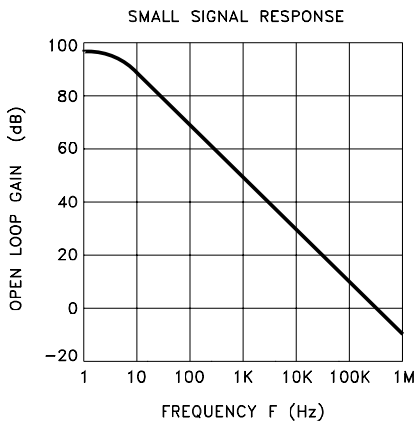
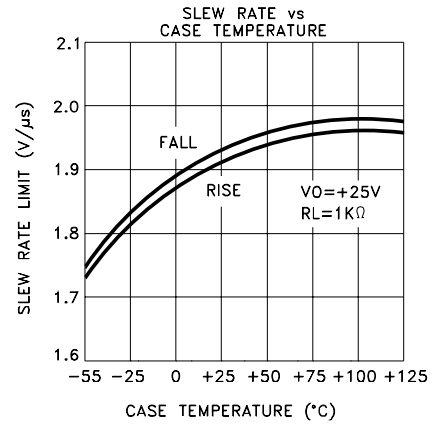
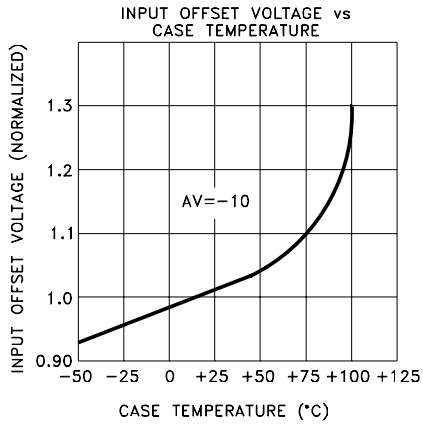
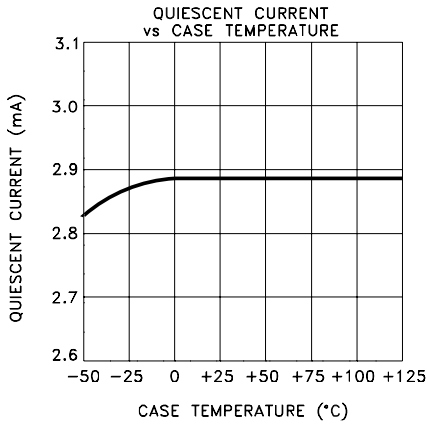

# MECHANICAL SPECIFICATIONS

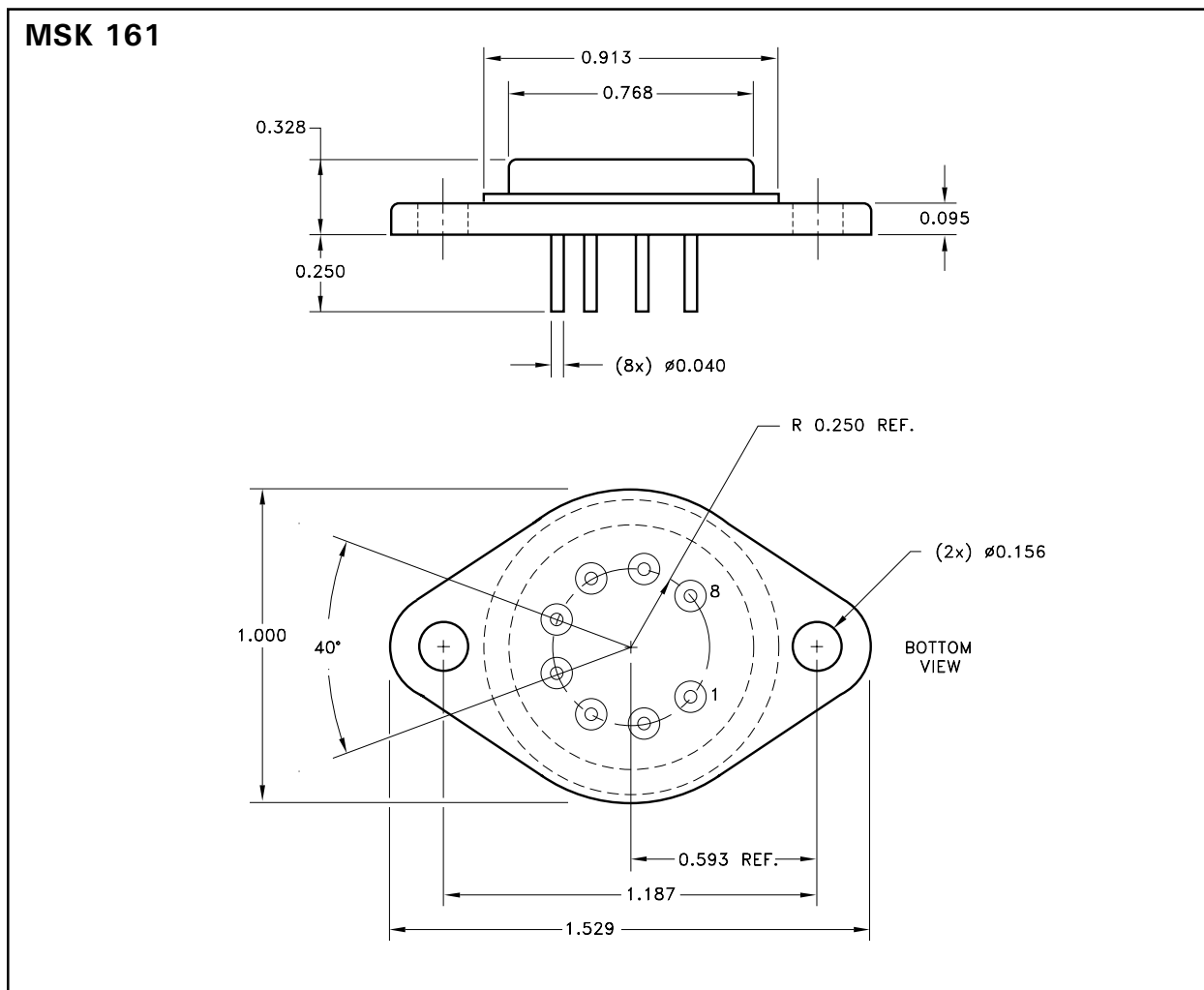

NOTE: ALL DIMENSIONS ARE  $\pm 0.010$  INCHES UNLESS OTHERWISE LABELED.

## ORDERING INFORMATION

Part Number	Screening Level
MSK161	Industrial
MSK 161E	Extended Reliability
MSK161B	Mil-PRF-38534 Class H

M.S. Kennedy Corp.  
 4707 Dey Road, Liverpool, New York 13088  
 Phone (315) 701-6751  
 FAX (315) 701-6752  
[www.mskennedy.com](http://www.mskennedy.com)

The information contained herein is believed to be accurate at the time of printing. MSK reserves the right to make changes to its products or specifications without notice, however, and assumes no liability for the use of its products. Please visit our website for the most recent revision of this datasheet.