

**3,622" x 3,622" x 1,496" 92 x 92 x 38 mm**

**113XP**

**ETRI®**

400 Hz Fans

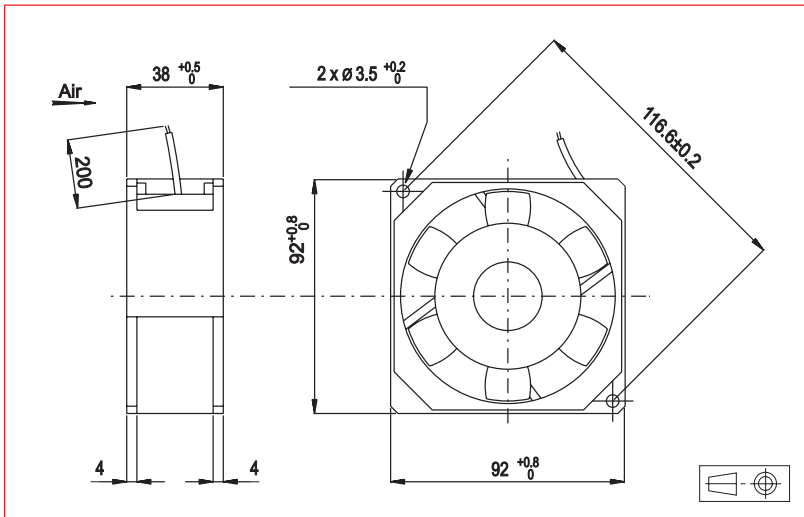

**Approvals**

NATO codification

**Life expectancy**

L-10 LIFE AT 40°C:  
35 000 hours

**400 Hz Motor**

Housing material: aluminium  
Impeller material: plastic UL 94 VO  
Weight: 480 g  
Bearing system: ball bearings

Connection: flying leads

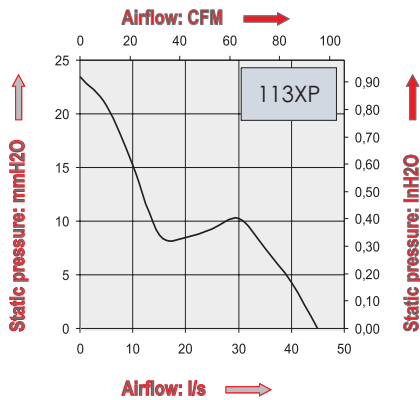

Part Number	Nominal voltage	Airflow	Noise level	Nominal speed	Phases	Capacitor	Input power	Nominal Current	Starting Current	Operating temperature	
	V	l/s	dB(A)	RPM		(not included) µF	W	mA	mA	Min.°C	Max.°C
113XP0162001	115	45	58	5500	3		19	180	435	-10	70
	115	45	58	5500	1	0,69	20	200	350	-10	70
113XP0160001	200	45	58	5500	3		19	105	250	-10	70
	200	45	58	5500	1	0,22	20	110	200	-10	70

**Additional versions:**

Salt spray protected - Shock and vibration protected - Marine specifications  
Wide temperature range

**Accessories:**

Refer to Accessories leaflet

