

DATA SHEET

EFD25/13/9

EFD cores and accessories

Supersedes data of September 2004

2008 Sep 01

CORES

Effective core parameters

SYMBOL	PARAMETER	VALUE	UNIT
$\Sigma(l/A)$	core factor (C1)	1.00	mm ⁻¹
V_e	effective volume	3300	mm ³
l_e	effective length	57.0	mm
A_e	effective area	58.0	mm ²
A_{min}	minimum area	55.0	mm ²
m	mass of core half	≈ 8	g

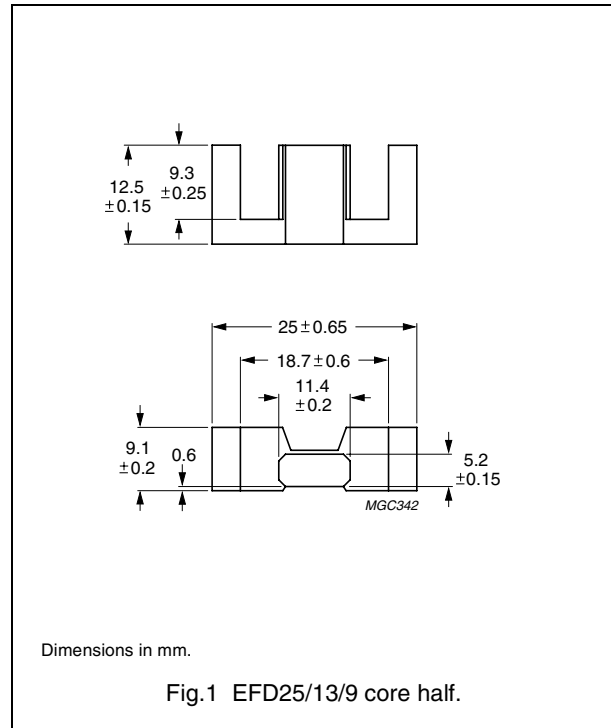

Core halves and sets

A_L measured as a set or in combination with a non-gapped core half, clamping force for A_L measurements, 40 ± 20 N.

GRADE	A_L (nH)	μ_e	AIR GAP (μm)	TYPE NUMBER
3C90	160 ± 3%	≈ 125	≈ 570	EFD25/13/9-3C90-A160
	250 ± 3%	≈ 196	≈ 320	EFD25/13/9-3C90-A250
	315 ± 5%	≈ 246	≈ 240	EFD25/13/9-3C90-A315
	400 ± 8%	≈ 313	≈ 180	EFD25/13/9-3C90-A400
	630 ± 10%	≈ 493	≈ 100	EFD25/13/9-3C90-A630
	2200 ± 25%	≈ 1720	≈ 0	EFD25/13/9-3C90
3C94	160 ± 3%	≈ 125	≈ 570	EFD25/13/9-3C94-A160
	250 ± 3%	≈ 196	≈ 320	EFD25/13/9-3C94-A250
	315 ± 5%	≈ 246	≈ 240	EFD25/13/9-3C94-A315
	400 ± 8%	≈ 313	≈ 180	EFD25/13/9-3C94-A400
	630 ± 10%	≈ 493	≈ 100	EFD25/13/9-3C94-A630
	2200 ± 25%	≈ 1720	≈ 0	EFD25/13/9-3C94
3C95 <small>des</small>	2660 ± 25%	≈ 2085	≈ 0	EFD25/13/9-3C95
3C96 <small>des</small>	2000 ± 25%	≈ 1560	≈ 0	EFD25/13/9-3C96

EFD cores and accessories

EFD25/13/9

GRADE	A_L (nH)	μ_e	AIR GAP (μm)	TYPE NUMBER
3F3	160 \pm 3%	\approx 125	\approx 570	EFD25/13/9-3F3-A160
	250 \pm 3%	\approx 196	\approx 320	EFD25/13/9-3F3-A250
	315 \pm 5%	\approx 246	\approx 240	EFD25/13/9-3F3-A315
	400 \pm 8%	\approx 313	\approx 180	EFD25/13/9-3F3-A400
	630 \pm 10%	\approx 493	\approx 100	EFD25/13/9-3F3-A630
	2000 \pm 25%	\approx 1560	\approx 0	EFD25/13/9-3F3
3F35 des	1500 \pm 25%	\approx 1170	\approx 0	EFD25/13/9-3F35
3F4 des	160 \pm 3%	\approx 125	\approx 500	EFD25/13/9-3F4-A160
	250 \pm 3%	\approx 196	\approx 270	EFD25/13/9-3F4-A250
	315 \pm 5%	\approx 246	\approx 290	EFD25/13/9-3F4-A315
	400 \pm 8%	\approx 313	\approx 130	EFD25/13/9-3F4-A400
	630 \pm 10%	\approx 493	\approx 60	EFD25/13/9-3F4-A630
	1000 \pm 25%	\approx 780	\approx 0	EFD25/13/9-3F4
3F45 prot	1000 \pm 25%	\approx 780	\approx 0	EFD25/13/9-3F45

Properties of core sets under power conditions

GRADE	B (mT) at	CORE LOSS (W) at				
	H = 250 A/m; f = 25 kHz; T = 100 °C	f = 25 kHz; \hat{B} = 200 mT; T = 100 °C	f = 100 kHz; \hat{B} = 100 mT; T = 100 °C	f = 100 kHz; \hat{B} = 200 mT; T = 25 °C	f = 100 kHz; \hat{B} = 200 mT; T = 100 °C	f = 400 kHz; \hat{B} = 50 mT; T = 100 °C
3C90	\geq 330	\leq 0.35	\leq 0.38	–	–	–
3C94	\geq 330	–	\leq 0.30	–	\leq 1.8	–
3C95	\geq 330	–	–	\leq 1.95	\leq 1.85	–
3C96	\geq 330	–	\leq 0.22	–	\leq 1.4	\leq 0.6
3F35	\geq 300	–	–	–	–	\leq 0.28
3F3	\geq 315	–	\leq 0.38	–	–	\leq 0.66
3F4	\geq 300	–	–	–	–	–

Properties of core sets under power conditions (continued)

GRADE	B (mT) at	CORE LOSS (W) at				
	H = 250 A/m; f = 25 kHz; T = 100 °C	f = 500 kHz; \hat{B} = 50 mT; T = 100 °C	f = 500 kHz; \hat{B} = 100 mT; T = 100 °C	f = 1 MHz; \hat{B} = 30 mT; T = 100 °C	f = 1 MHz; \hat{B} = 50 mT; T = 100 °C	f = 3 MHz; \hat{B} = 10 mT; T = 100 °C
3C90	\geq 330	–	–	–	–	–
3C94	\geq 330	–	–	–	–	–
3C95	\geq 330	–	–	–	–	–
3C96	\geq 330	\leq 1.2	–	–	–	–
3F35	\geq 300	\leq 0.42	\leq 3.4	–	–	–
3F3	\geq 315	–	–	–	–	–
3F4	\geq 300	–	–	\leq 1.0	–	\leq 1.6
3F45	\geq 300	–	–	\leq 0.75	\leq 2.8	\leq 1.25

COIL FORMERS

General data

PARAMETER	SPECIFICATION
Coil former material	phenolformaldehyde (PF), glass-reinforced, flame retardant in accordance with "UL 94V-0"; UL file number E167521(M)
Pin material	copper-tin alloy (CuSn), tin (Sn) plated, see note 1
Maximum operating temperature	180 °C, "IEC 60085", class H
Resistance to soldering heat	"IEC 60068-2-20", Part 2, Test Tb, method 1B, 350 °C, 3.5 s
Solderability	"IEC 60068-2-20", Part 2, Test Ta, method 1: 235 °C, 2 s

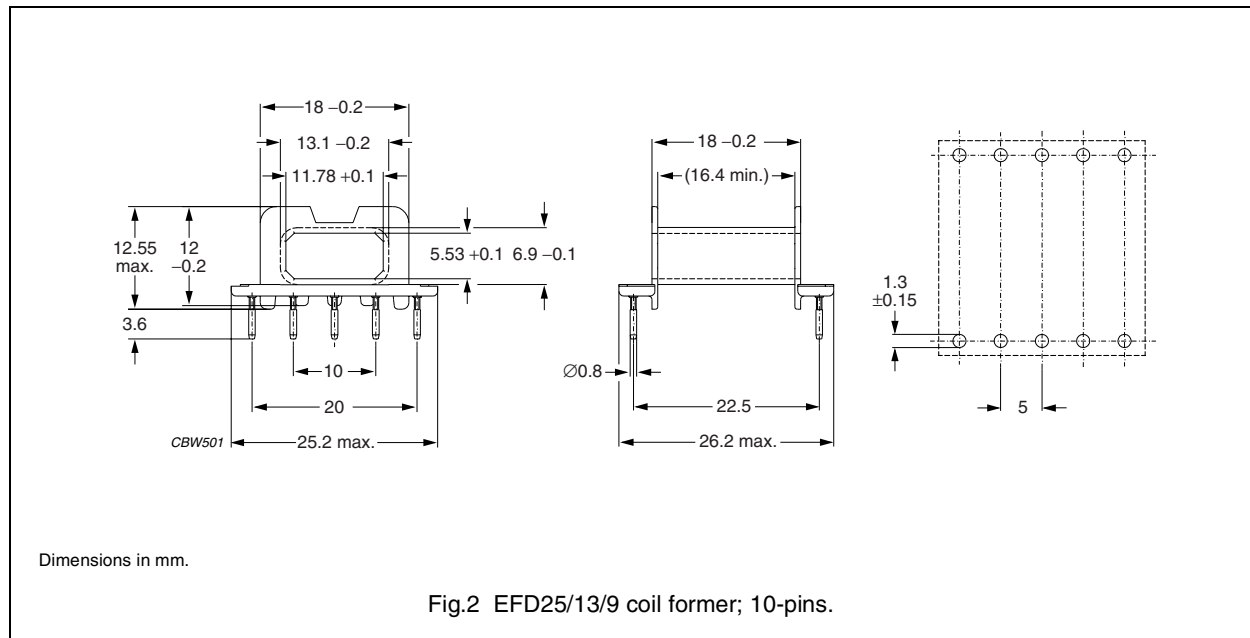

Winding data and area product for EFD25/13/9 coil former with 10-pins

NUMBER OF SECTIONS	WINDING AREA (mm ²)	MINIMUM WINDING WIDTH (mm)	AVERAGE LENGTH OF TURN (mm)	AREA PRODUCT Ae x Aw (mm ⁴)	TYPE NUMBER
1	40.2	16.4	46.4	2330	CSH-EFD25-1S-10P ⁽¹⁾

1. Also available with post-inserted pins.

COIL FORMERS

General data

PARAMETER	SPECIFICATION
Coil former material	Sumikon PM-9630 (PF), glass-reinforced, flame retardant in accordance with "UL 94V-0"; UL file number E41429
Pin material	copper-tin alloy (CuSn), Gold (Au) plated
Maximum operating temperature	180 °C, "IEC 60085", class H
Resistance to soldering heat	"IEC 60068-2-20", Part 2, Test Tb, method 1B, 350 °C, 3.5 s
Solderability	"IEC 60068-2-20", Part 2, Test Ta, method 1: 235 °C, 2 s

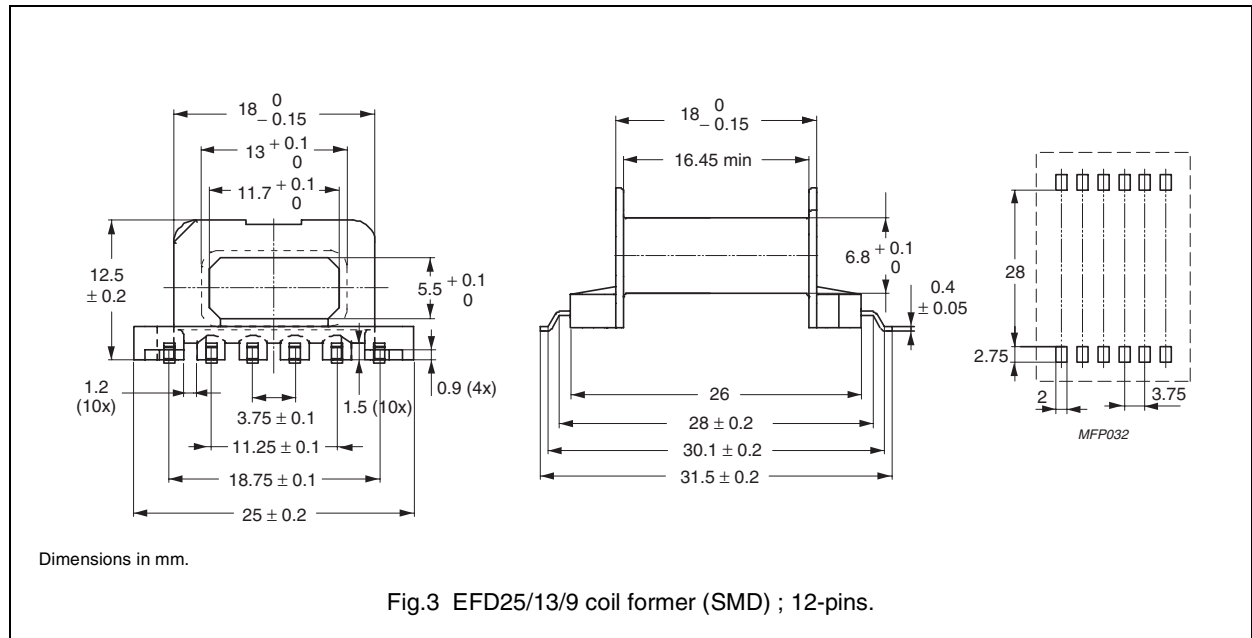

Winding data and area product for EFD25/13/9 coil former with 12-pins

NUMBER OF SECTIONS	WINDING AREA (mm ²)	MINIMUM WINDING WIDTH (mm)	AVERAGE LENGTH OF TURN (mm)	AREA PRODUCT Ae x Aw (mm ⁴)	TYPE NUMBER
1	39.0	16.45	46.4	2260	CSSH-EFD25-1S-12P

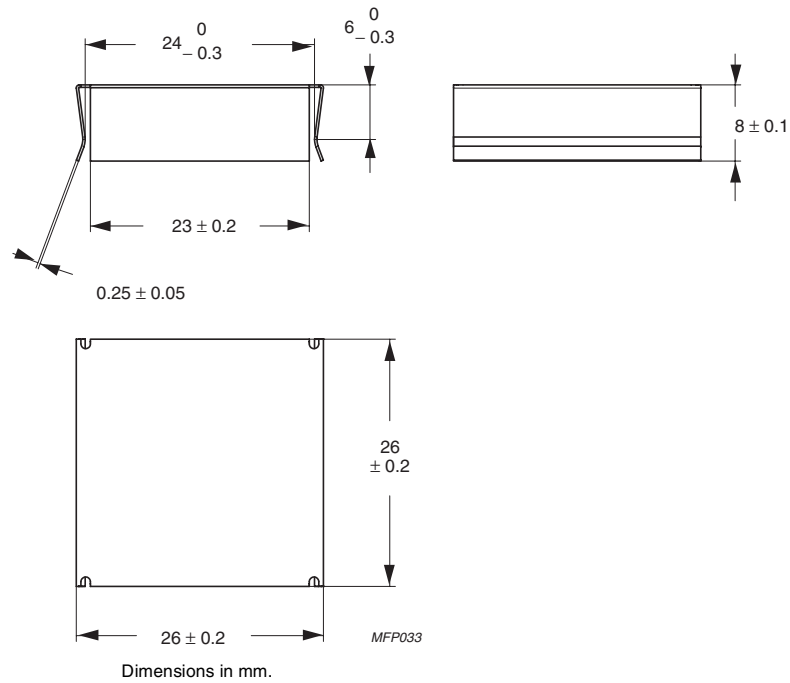

Fig.4 CLM-EFD25 mounting clamp.

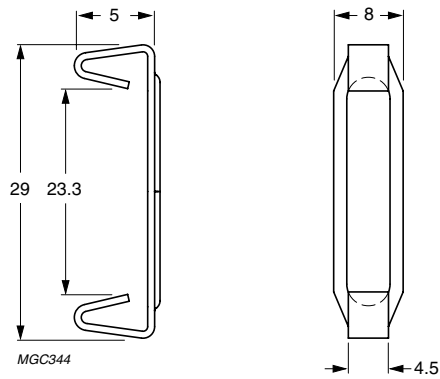

Fig.5 CLI-EFD25 mounting clip.

MOUNTING PARTS

General data

ITEM	REMARKS	FIGURE	TYPE NUMBER
Clip	stainless steel (CrNi); clamping force ≈ 30 N	4	CLI-EFD25
Clamp	stainless steel (CrNi); clamping force ≈ 30 N	5	CLM-EFD25



DATA SHEET STATUS DEFINITIONS

DATA SHEET STATUS	PRODUCT STATUS	DEFINITIONS
Preliminary specification	Development	This data sheet contains preliminary data. Ferroxcube reserves the right to make changes at any time without notice in order to improve design and supply the best possible product.
Product specification	Production	This data sheet contains final specifications. Ferroxcube reserves the right to make changes at any time without notice in order to improve design and supply the best possible product.

DISCLAIMER

Life support applications — These products are not designed for use in life support appliances, devices, or systems where malfunction of these products can reasonably be expected to result in personal injury. Ferroxcube customers using or selling these products for use in such applications do so at their own risk and agree to fully indemnify Ferroxcube for any damages resulting from such application.

PRODUCT STATUS DEFINITIONS

STATUS	INDICATION	DEFINITION
Prototype		These are products that have been made as development samples for the purposes of technical evaluation only. The data for these types is provisional and is subject to change.
Design-in		These products are recommended for new designs.
Preferred		These products are recommended for use in current designs and are available via our sales channels.
Support		These products are not recommended for new designs and may not be available through all of our sales channels. Customers are advised to check for availability.