

# DATA SHEET

**EFD10/5/3**

**EFD cores and accessories**

Supersedes data of September 2004

2008 Sep 01

**CORES**

**Effective core parameters**

SYMBOL	PARAMETER	VALUE	UNIT
$\Sigma(l/A)$	core factor (C1)	3.29	mm <sup>-1</sup>
$V_e$	effective volume	171	mm <sup>3</sup>
$l_e$	effective length	23.7	mm
$A_e$	effective area	7.2	mm <sup>2</sup>
$A_{min}$	minimum area	6.5	mm <sup>2</sup>
m	mass of core half	≈ 0.45	g

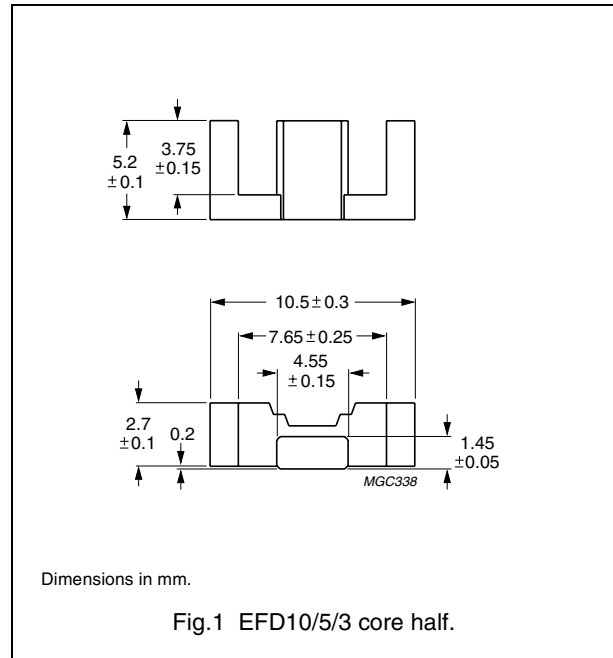

**Core sets**

Clamping force for  $A_L$  measurements,  $10 \pm 5$  N.

GRADE	$A_L$ (nH)	$\mu_e$	AIR GAP ( $\mu\text{m}$ )	TYPE NUMBER
3C90	25 ±5%	≈ 66	≈ 610	EFD10/5/3-3C90-A25-S
	40 ±8%	≈ 105	≈ 310	EFD10/5/3-3C90-A40-S
	63 ±10%	≈ 165	≈ 170	EFD10/5/3-3C90-A63-S
	585 ±25%	≈ 1510	≈ 0	EFD10/5/3-3C90-S
3C94	25 ±5%	≈ 66	≈ 610	EFD10/5/3-3C94-A25-S
	40 ±8%	≈ 105	≈ 310	EFD10/5/3-3C94-A40-S
	63 ±10%	≈ 165	≈ 170	EFD10/5/3-3C94-A63-S
	585 ±25%	≈ 1510	≈ 0	EFD10/5/3-3C94-S
3C96 <small>des</small>	525 ±25%	≈ 1360	≈ 0	EFD10/5/3-3C96-S
3F3	25 ±5%	≈ 66	≈ 610	EFD10/5/3-3F3-A25-S
	40 ±8%	≈ 105	≈ 310	EFD10/5/3-3F3-A40-S
	63 ±10%	≈ 165	≈ 170	EFD10/5/3-3F3-A63-S
	500 ±25%	≈ 1290	≈ 0	EFD10/5/3-3F3-S
3F35 <small>des</small>	400 ±25%	≈ 1030	≈ 0	EFD10/5/3-3F35-S
3F4 <small>des</small>	25 ±5%	≈ 66	≈ 570	EFD10/5/3-3F4-A25-S
	40 ±8%	≈ 105	≈ 280	EFD10/5/3-3F4-A40-S
	63 ±10%	≈ 165	≈ 150	EFD10/5/3-3F4-A63-S
	280 ±25%	≈ 730	≈ 0	EFD10/5/3-3F4-S
3F45 <small>prot</small>	280 ±25%	≈ 730	≈ 0	EFD10/5/3-3F45-S

## Properties of core sets under power conditions

GRADE	B (mT) at	CORE LOSS (W) at			
	H = 250 A/m; f = 25 kHz; T = 100 °C	f = 100 kHz; $\hat{B}$ = 100 mT; T = 100 °C	f = 100 kHz; $\hat{B}$ = 200 mT; T = 100 °C	f = 400 kHz; $\hat{B}$ = 50 mT; T = 100 °C	f = 500 kHz; $\hat{B}$ = 50 mT; T = 100 °C
3C90	≥320	≤ 0.019	–	–	–
3C94	≥320	≤ 0.015	≤ 0.09	–	–
3C96	≥340	≤ 0.01	≤ 0.07	≤ 0.03	≤ 0.06
3F35	≥300	–	–	≤ 0.015	≤ 0.03
3F3	≥315	≤ 0.020	–	≤ 0.035	–
3F4	≥250	–	–	–	–

## Properties of core sets under power conditions (continued)

GRADE	B (mT) at	CORE LOSS (W) at			
	H = 250 A/m; f = 25 kHz; T = 100 °C	f = 500 kHz; $\hat{B}$ = 100 mT; T = 100 °C	f = 1 MHz; $\hat{B}$ = 30 mT; T = 100 °C	f = 1 MHz; $\hat{B}$ = 50 mT; T = 100 °C	f = 3 MHz; $\hat{B}$ = 10 mT; T = 100 °C
3C90	≥320	–	–	–	–
3C94	≥320	–	–	–	–
3C96	≥320	–	–	–	–
3F35	≥300	≤ 0.2	–	–	–
3F3	≥315	–	–	–	–
3F4	≥250	–	≤ 0.05	–	≤ 0.08
3F45	≥250	–	≤ 0.04	≤ 0.15	≤ 0.065

**COIL FORMERS**

**General data**

PARAMETER	SPECIFICATION
Coil former material	liquid crystal polymer (LCP), glass reinforced, flame retardant in accordance with "UL 94V-0"; UL file number E54705(M)
Solder pad material	copper-tin alloy (CuSn), tin (Sn) plated
Maximum operating temperature	155 °C, "IEC 60085", class F
Resistance to soldering heat	"IEC 60068-2-20", Part 2, Test Tb, method 1B: 350 °C, 3.5 s
Solderability	"IEC 60068-2-20", Part 2, Test Ta, method 1: 235 °C, 2 s

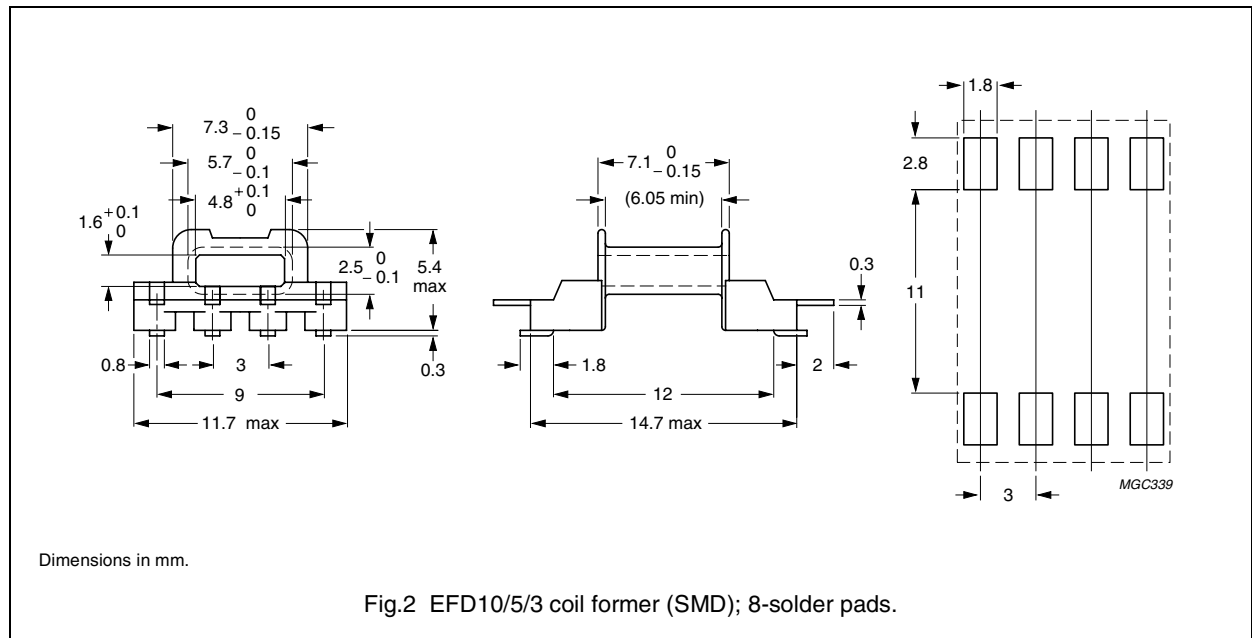

**Winding data and area product for EFD10/5/3 coil former (SMD) with 8-solder pads**

NUMBER OF SECTIONS	NUMBER OF SOLDER PADS	MINIMUM WINDING AREA (mm <sup>2</sup> )	MINIMUM WINDING WIDTH (mm)	AVERAGE LENGTH OF TURN (mm)	AREA PRODUCT Ae x Aw (mm <sup>4</sup> )	TYPE NUMBER
1	8	4.2	6.05	14.8	30.24	CPHS-EFD10-1S-8P

**MOUNTING PARTS****General data**

ITEM	REMARKS	FIGURE	TYPE NUMBER
Clamp	stainless steel (CrNi); clamping force $\approx 15$ N	3	CLM-EFD10

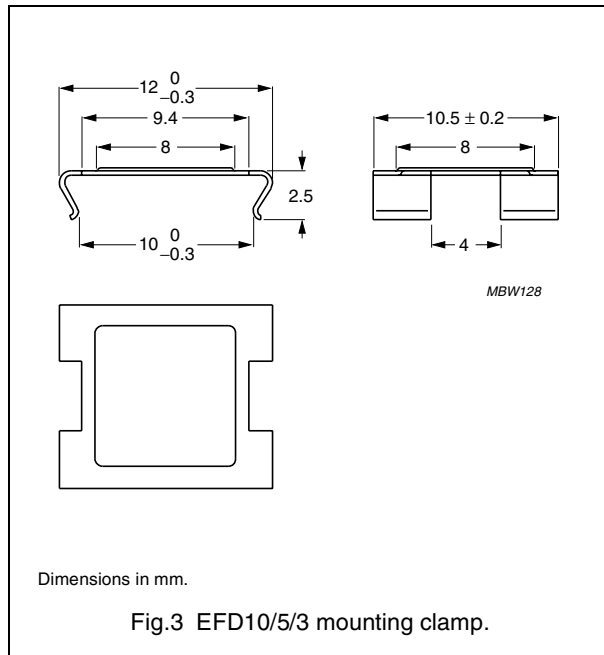



**DATA SHEET STATUS DEFINITIONS**

DATA SHEET STATUS	PRODUCT STATUS	DEFINITIONS
Preliminary specification	Development	This data sheet contains preliminary data. Ferroxcube reserves the right to make changes at any time without notice in order to improve design and supply the best possible product.
Product specification	Production	This data sheet contains final specifications. Ferroxcube reserves the right to make changes at any time without notice in order to improve design and supply the best possible product.

**DISCLAIMER**

**Life support applications** — These products are not designed for use in life support appliances, devices, or systems where malfunction of these products can reasonably be expected to result in personal injury. Ferroxcube customers using or selling these products for use in such applications do so at their own risk and agree to fully indemnify Ferroxcube for any damages resulting from such application.

**PRODUCT STATUS DEFINITIONS**

STATUS	INDICATION	DEFINITION
<b>Prototype</b>		These are products that have been made as development samples for the purposes of technical evaluation only. The data for these types is provisional and is subject to change.
<b>Design-in</b>		These products are recommended for new designs.
<b>Preferred</b>		These products are recommended for use in current designs and are available via our sales channels.
<b>Support</b>		These products are <b>not</b> recommended for new designs and may not be available through all of our sales channels. Customers are advised to check for availability.