

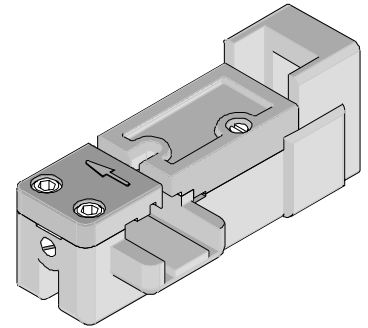

**IDT CHANGE HEAD
Specification Sheet
Order No. 11-21-5196
Engineering No. AM60116**



FEATURES

- This Change Head fits onto parallel action pistol hand tool part number 63600-0478.
- Internal indexing mechanism.
- Jumper style harnesses only (Feed To). For feed through termination use change head 62100-0400.
- Designed for prototype, small batch and field repair applications only.
- Useful life of this Change Head is 50,000 terminations; the Change Head should then be replaced.

SPECIFICATION

Size: 80mm by 37mm by 33mm
 Weight: 0.1kg
 Material: Plastic Construction

SCOPE

Products: KK ® IDT Double Cantilever Contact. 3.96mm (.156") pitch, 2 to 16 Circuits.

Color Identification		Type of Wire Terminated (All wires have a maximum insulation diameter of 2.41 mm (.095"))
Color Code	Slot Size	
Yellow	A	18 AWG solid or fused stranded wire
Red	M	20 AWG solid or fused stranded and 18 AWG stranded wire
Blue	L	20 AWG stranded wire
Green	D	26 and 27 AWG stranded, fused stranded and solid wire or 24 AWG stranded wire
Black	J	24 and 22 AWG solid or fused stranded wire and 22 AWG stranded wire

The following is a partial list of the product part numbers and their specifications that this tool is designed to run. We will be adding to this list and an up to date copy is available on www.molex.com.

Color Code Yellow				
Connector Series No	Connector Order No.			
7674	09-06-0020	09-06-0110	09-07-0059	09-07-0150
7674	09-06-0029	09-06-0119	09-07-0060	09-07-0159
7674	09-06-0030	09-06-0120	09-07-0069	09-07-0160
7674	09-06-0032	09-06-0129	09-07-0070	09-07-0169
7674	09-06-0039	09-06-0130	09-07-0079	26-32-4024
7674	09-06-0040	09-06-0139	09-07-0080	26-32-4034
7674	09-06-0049	09-06-0140	09-07-0089	26-32-4044
7674	09-06-0050	09-06-0149	09-07-0090	26-32-4054
7674	09-06-0059	09-06-0150	09-07-0099	26-32-4064
7674	09-06-0060	09-06-0159	09-07-0100	26-32-4074
7674	09-06-0069	09-06-0160	09-07-0109	26-32-4084
7674	09-06-0070	09-06-0169	09-07-0110	26-32-4094
7674	09-06-0079	09-07-0020	09-07-0119	26-32-4104
7674	09-06-0080	09-07-0029	09-07-0120	26-32-4114

Color Code Yellow				
Connector Series No	Connector Order No.			
7674	09-06-0089	09-07-0030	09-07-0129	26-32-4124
7674	09-06-0090	09-07-0039	09-07-0130	26-32-4134
7674	09-06-0099	09-07-0040	09-07-0139	26-32-4144
7674	09-06-0100	09-07-0049	09-07-0140	26-32-4154
7674	09-06-0109	09-07-0050	09-07-0149	26-32-4164
7675	09-05-0117	09-06-0177	09-07-0098	09-07-5112
7675	09-06-0027	09-06-0178	09-07-0107	26-32-0103
7675	09-06-0028	09-06-0187	09-07-0108	26-32-0163
7675	09-06-0037	09-06-0188	09-07-0117	26-32-9020
7675	09-06-0038	09-06-0197	09-07-0118	26-32-9024
7675	09-06-0047	09-06-0198	09-07-0127	26-32-9030
7675	09-06-0048	09-06-0207	09-07-0128	26-32-9034
7675	09-06-0057	09-06-0208	09-07-0137	26-32-9040

Change head for IDT Connectors Series

Color Code Yellow				
Connector Series No	Connector Order No.			
7675	09-06-0058	09-06-0217	09-07-0138	26-32-9044
7675	09-06-0067	09-06-0218	09-07-0147	26-32-9050
7675	09-06-0068	09-06-0227	09-07-0148	26-32-9060
7675	09-06-0077	09-06-0228	09-07-0157	26-32-9064
7675	09-06-0078	09-06-0237	09-07-0158	26-32-9070
7675	09-06-0087	09-06-0238	09-07-0167	26-32-9080
7675	09-06-0088	09-06-0247	09-07-0168	26-32-9084
7675	09-06-0097	09-06-0248	09-07-0177	26-32-9090
7675	09-06-0098	09-07-0027	09-07-0178	26-32-9100
7675	09-06-0107	09-07-0028	09-07-0187	26-32-9110
7675	09-06-0108	09-07-0037	09-07-0188	26-32-9120
7675	09-06-0117	09-07-0038	09-07-0197	26-32-9130
7675	09-06-0118	09-07-0047	09-07-0198	26-32-9140
7675	09-06-0127	09-07-0048	09-07-0207	26-32-9160
7675	09-06-0128	09-07-0057	09-07-0208	26-32-9170
7675	09-06-0137	09-07-0058	09-07-0217	26-32-9180
7675	09-06-0138	09-07-0067	09-07-0218	26-32-9190
7675	09-06-0147	09-07-0068	09-07-0227	26-32-9200
7675	09-06-0148	09-07-0077	09-07-0228	26-32-9210
7675	09-06-0157	09-07-0078	09-07-0237	26-32-9220
7675	09-06-0158	09-07-0087	09-07-0238	26-32-9230
7675	09-06-0167	09-07-0088	09-07-0247	26-32-9240
7675	09-06-0168	09-07-0097	09-07-0248	

Color Code Red				
Connector Series No	Connector Order No.			
7674	09-06-1020	09-06-1149	09-07-1120	50-29-1979
7674	09-06-1029	09-06-1150	09-07-1129	50-29-1980
7674	09-06-1030	09-06-1159	09-07-1130	50-29-1981
7674	09-06-1039	09-06-1160	09-07-1139	50-29-1982
7674	09-06-1040	09-06-1169	09-07-1140	50-29-1983
7674	09-06-1049	09-07-1020	09-07-1149	50-29-1984
7674	09-06-1050	09-07-1029	09-07-1150	50-29-1985
7674	09-06-1059	09-07-1030	09-07-1159	50-29-1986
7674	09-06-1060	09-07-1039	09-07-1160	50-29-1987
7674	09-06-1069	09-07-1040	09-07-1169	50-29-1988
7674	09-06-1070	09-07-1049	26-32-4111	50-29-1989
7674	09-06-1079	09-07-1050	26-32-6034	50-29-1990
7674	09-06-1080	09-07-1059	26-32-6044	50-29-1991
7674	09-06-1089	09-07-1060	26-32-6064	50-29-1992
7674	09-06-1090	09-07-1069	26-32-6074	50-29-1993
7674	09-06-1099	09-07-1070	26-32-6104	50-29-1994
7674	09-06-1100	09-07-1079	50-29-1591	50-29-1995
7674	09-06-1109	09-07-1080	50-29-1592	50-29-1996
7674	09-06-1110	09-07-1089	50-29-1972	50-29-1997
7674	09-06-1119	09-07-1090	50-29-1973	50-29-1998
7674	09-06-1120	09-07-1099	50-29-1974	50-29-1999
7674	09-06-1129	09-07-1100	50-29-1975	50-29-2000
7674	09-06-1130	09-07-1109	50-29-1976	50-29-2001
7674	09-06-1139	09-07-1110	50-29-1977	
7674	09-06-1140	09-07-1119	50-29-1978	

Color Code Red				
Connector Series No	Connector Order No.			
7675	09-06-1027	09-06-1208	09-07-1167	26-32-1141
7675	09-06-1028	09-06-1217	09-07-1168	26-32-1143
7675	09-06-1037	09-06-1218	09-07-1177	26-32-1153
7675	09-06-1038	09-06-1227	09-07-1178	26-32-1162
7675	09-06-1047	09-06-1228	09-07-1187	26-32-1181
7675	09-06-1048	09-06-1237	09-07-1188	26-32-1182
7675	09-06-1057	09-06-1238	09-07-1197	26-32-1201
7675	09-06-1058	09-06-1247	09-07-1198	26-32-1203
7675	09-06-1067	09-06-1248	09-07-1207	26-32-7024
7675	09-06-1068	09-07-1027	09-07-1208	26-32-7032
7675	09-06-1077	09-07-1028	09-07-1217	26-32-7034
7675	09-06-1078	09-07-1037	09-07-1218	26-32-7044
7675	09-06-1088	09-07-1038	09-07-1227	26-32-7054
7675	09-06-1087	09-07-1047	09-07-1228	26-32-7062
7675	09-06-1097	09-07-1048	09-07-1237	26-32-7063
7675	09-06-1098	09-07-1057	09-07-1238	26-32-7064
7675	09-06-1107	09-07-1058	09-07-1247	26-32-7074
7675	09-06-1108	09-07-1067	09-07-1248	26-32-7082
7675	09-06-1117	09-07-1068	09-07-5094	26-32-7084
7675	09-06-1118	09-07-1077	09-07-5104	26-32-7094
7675	09-06-1127	09-07-1078	09-07-7091	26-32-7104
7675	09-06-1128	09-07-1087	09-09-3169	26-32-7114
7675	09-06-1137	09-07-1088	09-09-4039	26-32-7124
7675	09-06-1138	09-07-1097	09-09-4062	26-32-7134
7675	09-06-1147	09-07-1098	09-09-4074	26-32-7144
7675	09-06-1148	09-07-1107	09-09-4075	26-32-7154
7675	09-06-1157	09-07-1108	09-09-4076	26-32-7164
7675	09-06-1158	09-07-1117	09-09-4077	26-32-7174
7675	09-06-1167	09-07-1118	09-09-4081	26-32-7184
7675	09-06-1168	09-07-1127	09-09-4083	26-32-7194
7675	09-06-1177	09-07-1128	09-09-4101	26-32-7204
7675	09-06-1178	09-07-1137	09-09-4115	26-32-7214
7675	09-06-1187	09-07-1138	26-32-1074	26-32-7224
7675	09-06-1188	09-07-1147	26-32-1084	26-32-7234
7675	09-06-1197	09-07-1148	26-32-1102	26-32-7244
7675	09-06-1198	09-07-1157	26-32-1104	26-38-1048
7675	09-06-1207	09-07-1158	26-32-1124	26-38-2168

Color Code Blue				
Connector Series No	Connector Order No.			
7674	09-06-2020	09-06-2139	09-07-2100	26-32-2064
7674	09-06-2029	09-06-2140	09-07-2109	26-32-2072
7674	09-06-2030	09-06-2149	09-07-2110	26-32-2074
7674	09-06-2039	09-06-2150	09-07-2119	26-32-2082
7674	09-06-2040	09-06-2159	09-07-2120	26-32-2084
7674	09-06-2049	09-06-2160	09-07-2129	26-32-2092
7674	09-06-2050	09-06-2169	09-07-2130	26-32-2094
7674	09-06-2059	09-07-2020	09-07-2139	26-32-2102
7674	09-06-2060	09-07-2029	09-07-2140	26-32-2104
7674	09-06-2069	09-07-2030	09-07-2149	26-32-2112
7674	09-06-2070	09-07-2039	09-07-2150	26-32-2114

Change head for IDT Connectors Series

Color Code Blue				
Connector Series No	Connector Order No.			
7674	09-06-2079	09-07-2040	09-07-2159	26-32-2122
7674	09-06-2080	09-07-2049	09-07-2160	26-32-2124
7674	09-06-2089	09-07-2050	09-07-2169	26-32-2132
7674	09-06-2090	09-07-2059	26-32-2022	26-32-2134
7674	09-06-2099	09-07-2060	26-32-2024	26-32-2142
7674	09-06-2100	09-07-2069	26-32-2032	26-32-2144
7674	09-06-2109	09-07-2070	26-32-2034	26-32-2152
7674	09-06-2110	09-07-2079	26-32-2042	26-32-2154
7674	09-06-2119	09-07-2080	26-32-2044	26-32-2162
7674	09-06-2120	09-07-2089	26-32-2052	26-32-2164
7674	09-06-2129	09-07-2090	26-32-2054	
7674	09-06-2130	09-07-2099	26-32-2062	
7675	09-06-2027	09-06-2148	09-07-2037	09-07-2158
7675	09-06-2028	09-06-2157	09-07-2038	09-07-2167
7675	09-06-2037	09-06-2158	09-07-2047	09-07-2168
7675	09-06-2038	09-06-2167	09-07-2048	09-07-2177
7675	09-06-2047	09-06-2168	09-07-2057	09-07-2178
7675	09-06-2048	09-06-2177	09-07-2058	09-07-2187
7675	09-06-2057	09-06-2178	09-07-2067	09-07-2188
7675	09-06-2058	09-06-2187	09-07-2068	09-07-2197
7675	09-06-2067	09-06-2188	09-07-2077	09-07-2198
7675	09-06-2068	09-06-2197	09-07-2078	09-07-2207
7675	09-06-2077	09-06-2198	09-07-2087	09-07-2208
7675	09-06-2078	09-06-2207	09-07-2088	09-07-2217
7675	09-06-2087	09-06-2208	09-07-2097	09-07-2218
7675	09-06-2088	09-06-2217	09-07-2098	09-07-2227
7675	09-06-2097	09-06-2218	09-07-2107	09-07-2228
7675	09-06-2098	09-06-2227	09-07-2108	09-07-2237
7675	09-06-2107	09-06-2228	09-07-2117	09-07-2238
7675	09-06-2108	09-06-2237	09-07-2118	09-07-2247
7675	09-06-2117	09-06-2238	09-07-2127	09-07-2248
7675	09-06-2118	09-06-2247	09-07-2128	26-31-2028
7675	09-06-2127	09-06-2248	09-07-2137	26-31-2148
7675	09-06-2128	09-06-7055	09-07-2138	26-31-2207
7675	09-06-2137	09-06-7145	09-07-2147	
7675	09-06-2138	09-07-2027	09-07-2148	
7675	09-06-2147	09-07-2028	09-07-2157	

Color Code Green				
Connector Series No	Connector Order No.			
7674	09-06-3020	09-06-3099	09-07-3020	09-07-3099
7674	09-06-3029	09-06-3100	09-07-3029	09-07-3100
7674	09-06-3030	09-06-3109	09-07-3030	09-07-3109
7674	09-06-3039	09-06-3110	09-07-3039	09-07-3110
7674	09-06-3040	09-06-3119	09-07-3040	09-07-3119
7674	09-06-3049	09-06-3120	09-07-3049	09-07-3120
7674	09-06-3050	09-06-3129	09-07-3050	09-07-3129
7674	09-06-3059	09-06-3130	09-07-3059	09-07-3130
7674	09-06-3060	09-06-3139	09-07-3060	09-07-3139
7674	09-06-3069	09-06-3140	09-07-3069	09-07-3140
7674	09-06-3070	09-06-3149	09-07-3070	09-07-3149

Color Code Green				
Connector Series No	Connector Order No.			
7674	09-06-3079	09-06-3150	09-07-3079	09-07-3150
7674	09-06-3080	09-06-3159	09-07-3080	09-07-3159
7674	09-06-3089	09-06-3160	09-07-3089	09-07-3160
7674	09-06-3090	09-06-3169	09-07-3090	09-07-3169
7675	09-06-3027	09-06-3147	09-07-3037	09-07-3157
7675	09-06-3028	09-06-3148	09-07-3038	09-07-3158
7675	09-06-3037	09-06-3157	09-07-3047	09-07-3167
7675	09-06-3038	09-06-3158	09-07-3048	09-07-3168
7675	09-06-3047	09-06-3167	09-07-3057	09-07-3177
7675	09-06-3048	09-06-3168	09-07-3058	09-07-3178
7675	09-06-3057	09-06-3177	09-07-3067	09-07-3187
7675	09-06-3058	09-06-3178	09-07-3068	09-07-3188
7675	09-06-3067	09-06-3187	09-07-3077	09-07-3197
7675	09-06-3068	09-06-3188	09-07-3078	09-07-3198
7675	09-06-3077	09-06-3197	09-07-3087	09-07-3207
7675	09-06-3078	09-06-3198	09-07-3088	09-07-3208
7675	09-06-3087	09-06-3207	09-07-3097	09-07-3217
7675	09-06-3088	09-06-3208	09-07-3098	09-07-3218
7675	09-06-3097	09-06-3217	09-07-3107	09-07-3227
7675	09-06-3098	09-06-3218	09-07-3108	09-07-3228
7675	09-06-3107	09-06-3227	09-07-3117	09-07-3237
7675	09-06-3108	09-06-3228	09-07-3118	09-07-3238
7675	09-06-3117	09-06-3237	09-07-3127	09-07-3247
7675	09-06-3118	09-06-3238	09-07-3128	09-07-3248
7675	09-06-3127	09-06-3247	09-07-3137	26-32-3068
7675	09-06-3128	09-06-3248	09-07-3138	26-32-3089
7675	09-06-3137	09-07-3027	09-07-3147	
7675	09-06-3138	09-07-3028	09-07-3148	

Color Code Black				
Connector Series No	Connector Order No.			
7674	09-10-2117	09-06-5130	09-07-5100	26-32-1069
7674	09-10-2156	09-06-5139	09-07-5109	26-32-1077
7674	09-06-5020	09-06-5140	09-07-5110	26-32-1079
7674	09-06-5029	09-06-5149	09-07-5119	26-32-1087
7674	09-06-5030	09-06-5150	09-07-5120	26-32-1089
7674	09-06-5039	09-06-5159	09-07-5129	26-32-1097
7674	09-06-5040	09-06-5160	09-07-5130	26-32-1099
7674	09-06-5049	09-06-5169	09-07-5139	26-32-1107
7674	09-06-5050	09-07-5020	09-07-5140	26-32-1109
7674	09-06-5059	09-07-5029	09-07-5149	26-32-1117
7674	09-06-5060	09-07-5030	09-07-5150	26-32-1119
7674	09-06-5069	09-07-5039	09-07-5159	26-32-1127
7674	09-06-5070	09-07-5040	09-07-5160	26-32-1129
7674	09-06-5079	09-07-5049	09-07-5169	26-32-1137
7674	09-06-5080	09-07-5050	26-32-1025	26-32-1139
7674	09-06-5089	09-07-5059	26-32-1027	26-32-1147
7674	09-06-5090	09-07-5060	26-32-1035	26-32-1149
7674	09-06-5099	09-07-5069	26-32-1037	26-32-1157
7674	09-06-5100	09-07-5070	26-32-1047	26-32-1159
7674	09-06-5109	09-07-5079	26-32-1049	26-32-1167

Color Code Black				
Connector Series No	Connector Order No.			
7674	09-06-5110	09-07-5080	26-32-1057	26-32-1169
7674	09-06-5119	09-07-5089	26-32-1059	50-29-1556
7674	09-06-5120	09-07-5090	26-32-1063	
7674	09-06-5129	09-07-5099	26-32-1067	
7675	09-06-5027	09-06-5168	09-07-5078	09-07-5218
7675	09-06-5028	09-06-5177	09-07-5087	09-07-5227
7675	09-06-5037	09-06-5178	09-07-5088	09-07-5228
7675	09-06-5038	09-06-5187	09-07-5097	09-07-5237
7675	09-06-5047	09-06-5188	09-07-5098	09-07-5238
7675	09-06-5048	09-06-5197	09-07-5107	09-07-5247
7675	09-06-5057	09-06-5198	09-07-5108	09-07-5248
7675	09-06-5058	09-06-5207	09-07-5117	09-10-5109
7675	09-06-5067	09-06-5208	09-07-5118	09-10-5149
7675	09-06-5068	09-06-5217	09-07-5127	09-10-5169
7675	09-06-5077	09-06-5218	09-07-5128	21-62-2001
7675	09-06-5078	09-06-5227	09-07-5137	26-31-5028
7675	09-06-5087	09-06-5228	09-07-5138	26-31-5038

Color Code Black				
Connector Series No	Connector Order No.			
7675	09-06-5088	09-06-5237	09-07-5147	26-31-5048
7675	09-06-5097	09-06-5238	09-07-5148	26-31-5058
7675	09-06-5098	09-06-5247	09-07-5157	26-31-5068
7675	09-06-5107	09-06-5248	09-07-5158	26-31-5088
7675	09-06-5108	09-07-5027	09-07-5167	26-31-5108
7675	09-06-5117	09-07-5028	09-07-5168	26-31-5158
7675	09-06-5118	09-07-5037	09-07-5177	26-32-5048
7675	09-06-5127	09-07-5038	09-07-5178	26-32-5067
7675	09-06-5128	09-07-5047	09-07-5187	26-32-5068
7675	09-06-5137	09-07-5048	09-07-5188	26-32-5129
7675	09-06-5138	09-07-5057	09-07-5197	26-32-9025
7675	09-06-5147	09-07-5058	09-07-5198	26-32-9085
7675	09-06-5148	09-07-5067	09-07-5207	26-32-9155
7675	09-06-5157	09-07-5068	09-07-5208	26-38-5067
7675	09-06-5158	09-07-5077	09-07-5217	26-38-5068
7675	09-06-5167			

DESCRIPTION

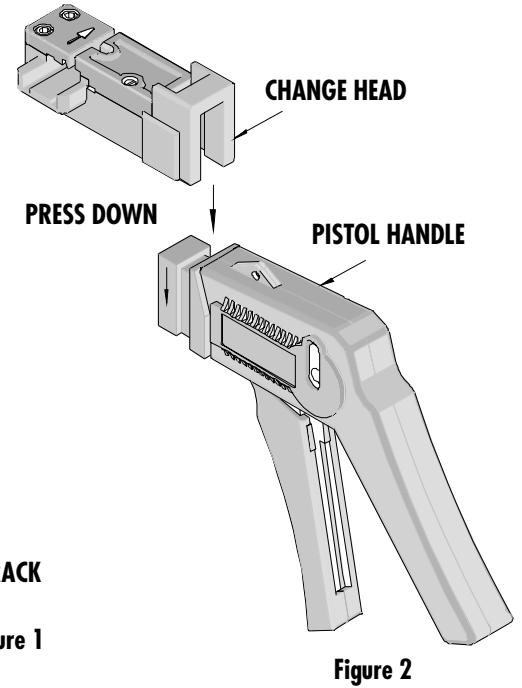
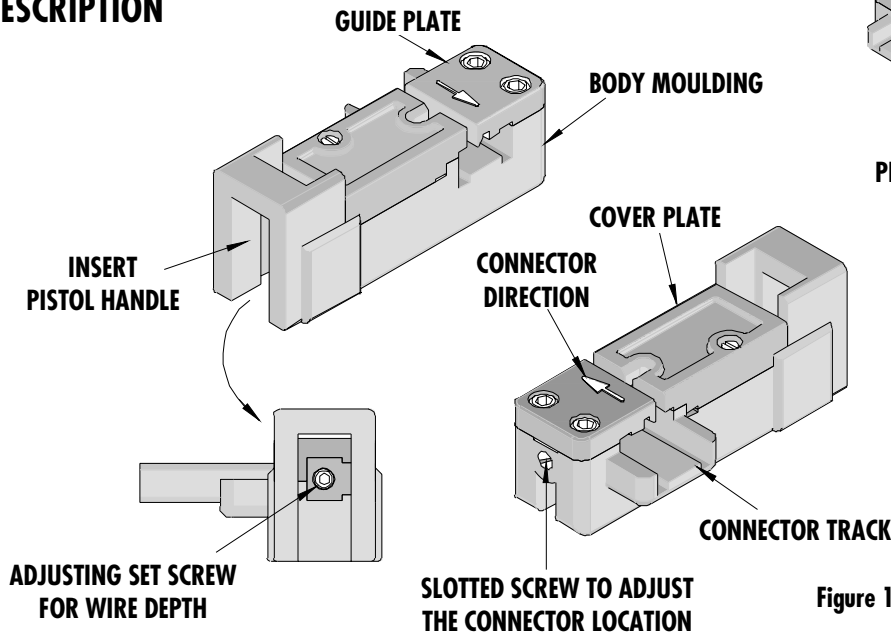

OPERATION

1. Orient the Change Head over the pistol hand tool (63600-0478). On the side of the piston handle there is an assembly directional arrow. Press the change head firmly down onto the piston hand tool until it snaps in place. See Figure 2.

CAUTION: Operating handle of pistol should not be actuated prior to pistol change head assembly.

2. Place the proper connector into the track; the rib of the connector should be facing up. See Figure 3.
3. Compress the front pistol handle and slide the connector into the Change Head track until it stops, release the pistol handle.
4. Operate the pistol to index the connector into the change head.
5. Place the proper wire into the slot above the connector. Make sure that the wire is fully seated.
6. Close the piston hand tool by moving the front operating handle while holding the wire in place.
7. Release the operating handle gently. During the return stroke the housing will automatically advance to the next circuit position.
8. Check for wire insulation depth in the location slot. The wire insulation must be just below the "eagle" of the connector housing. See Figure 4.
9. Repeat steps 4 thru 7 above for placement of additional wires until the last circuit of the housing is completed.
10. To remove the completed wire/housing assembly from the piston hand tool, slide the assembly to the right and push out.

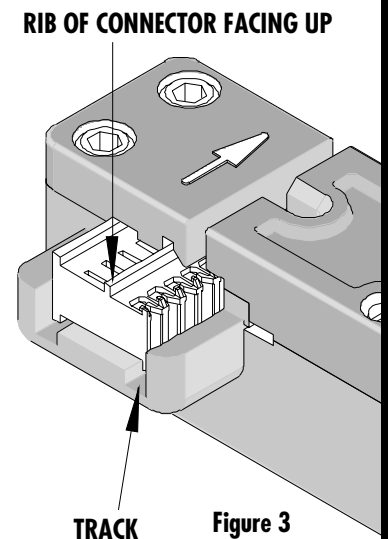

Figure 3

Note: After the last wire insertion has been made in the connector assembly, the assembly will not advance any further because the feed pawl will have cleared the end of the connector body.

ADJUSTMENTS

Wire Insertion Depth

1. Remove the Change Head from the pistol handle.
2. To adjust the insertion depth of the wire use the Allen wrench which is included with Change Head.
3. Place the Allen wrench into the feed adjustment set screw, which is located in the mounting slot of the change head that goes into the piston handle. See Figure 1.
4. By rotating this setscrew, the insertion depth can be changed.
5. Clockwise (CW) will increase wire insertion depth. Counter Clockwise (CCW) will decrease wire insertion depth.

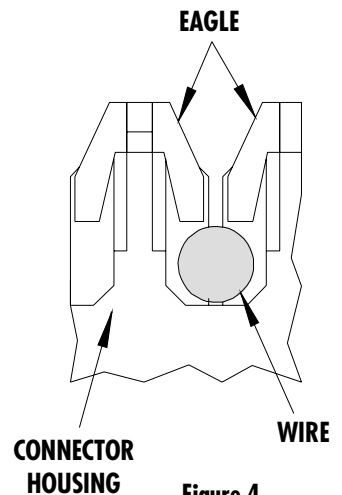

Figure 4

Guide Plate

The two fixing screws on the front guide plate offer a small amount of track adjustment. This should only be adjusted if the connector does not run smoothly through the track.

Connector Locator

The small slotted spring ball screw in the body molding of the change head is used to adjust the connector locator.

1. The spring ball screw should be loosened for 2,3,4, and 5 circuits size connector housings using a 3mm wide screwdriver blade. See Figure 1.
2. For larger circuit size connector housing the spring ball screw should be tightened. This will ensure correct and consistent feed action during operation.

This is set at the factory and should not require adjustment.

CAUTION: This change head should be used in accordance with the operation procedure. Any misuse may cause injury to operator.

Quality

Check termination quality against the Molex wire termination specification for relevant product being terminated e.g.: PS-7674. A quality procedure should be in place to monitor output from this Change Head.

The operating pistol handle is ratcheted to ensure correct wire insertion depth. This hand tool is set at the factory at a stroke of 11.7mm (.46") and should not need adjusting. See Instruction Manual 63600-0478 for information.

Maintenance

It is recommended that each operator of the tool be made aware of, and responsible for, the following maintenance steps:

1. Keep Change Head clean at all times. Remove dust, moisture, and other contaminants with a clean brush, or soft, lint free cloth.
2. Look into the track at the index and termination punch positions, if dirty or contains any plastic particles, then clean using a brush or similar.
3. Do not use any abrasive materials that could damage the tool.
4. Make certain all pins; pivot points and bearing surfaces are protected with a thin coat of high quality machine oil. Do not oil excessively.
5. When tool is not in use store the tool in a clean, dry area.

Warranty

This tool is made of the best quality materials. All vital components are long life tested. All tools are warranted to be free of manufacturing defects for a period of **30 days**. Should such a defect occur, we would exchange the tool free of charge. This will not be applicable to altered, misused, or damaged tools. This tool is designed for hand use only. Any clamping, fixturing, or use of handle extensions voids this warranty.

Molex does not repair this tool or offer any repair parts for this change head tool.

This tool is intended for low volume, prototyping, or repair requirements only. It is not intended as a production tool.

CAUTION: Molex termination specifications are valid only when used with Molex connectors and tooling.

Americas Headquarters

Lisle, Illinois 60532 U.S.A.
1-800-78MOLEX
amerinfo@molex.com

Far East North Headquarters

Yamato, Kanagawa, Japan
81-462-65-2324
feninfo@molex.com

Far East South Headquarters

Jurong, Singapore
65-6-268-6868
fesinfo@molex.com

European Headquarters

Munich, Germany
49-89-413092-0
eurinfo@molex.com

Corporate Headquarters

2222 Wellington Ct.
Lisle, IL 60532 U.S.A.
630-969-4550
Fax: 630-969-1352

Visit our Web site at <http://www.molex.com>