

10 9 8 7 6 5 4 3 2 1

F  
E  
D  
C  
B  
A

F  
E  
D  
C  
B  
A

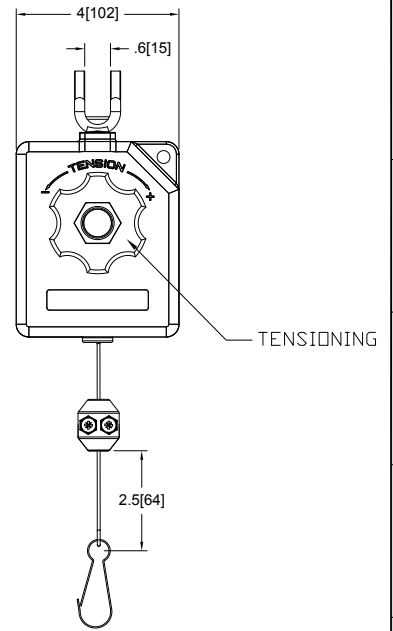

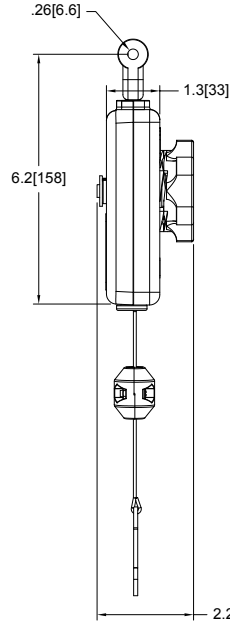
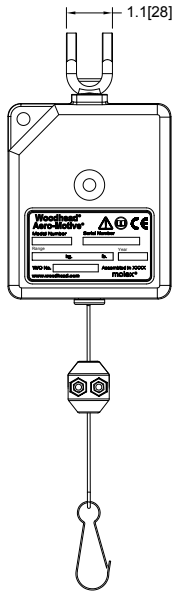
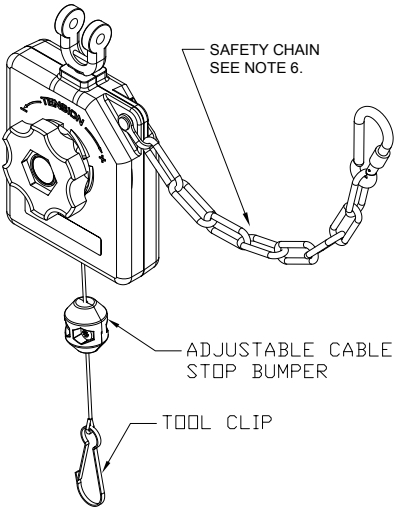

- NOTES:
1. RETRACTORS ARE 100% INSPECTED & PRE-TENSIONED AT FACTORY.
  2. HOUSINGS ARE MADE OF GENERAL PURPOSE ABS TO MEET HARSH INDUSTRIAL ENVIRONMENTS.
  3. ALWAYS READ INSTRUCTIONS MANUAL BEFORE USING RETRACTORS.
  4. RETRACTORS ARE NOT TO BE USED AS BALANCERS THEIR MAIN PURPOSE BEING TO RETRACT A LOAD AND NOT TO BALANCE ONE.
  5. OVERALL DIMENSIONS ARE FOR REFERENCE ONLY.
  6. STANDARD CATALOG RETRACTORS ARE NOT EQUIPED WITH SAFETY CHAIN. BUT IF APPLICATION REQUIRES A SAFETY CHAIN ADD "SC" SUFFIX TO STANDARD BALANCER P/N. EXAMPLE RB2SC. ON MAIN MATERIAL NUMBERS TABLE.
  7. RETRACTORS COME WITH A CLEVIS PIN & A COTTER PIN

ALL DIMENSIONS ARE FOR REFERENCE ONLY.

RELEASE TO GSM EC NO: WNA2010-0605 DRAWN: RHOTCA 2010/03/25 CHECKED: DT APPROVED: DTTUS 2010/03/31 REV: A	DESCRIPTION I QUALITY SYMBOLS $\nabla=0$ $\nabla Z=0$	GENERAL TOLERANCES (UNLESS SPECIFIED)		DIMENSION STYLE IN/MM		SCALE	DESIGN UNITS	THIRD ANGLE PROJECTION	
		4 PLACES	±	±	DRAWN BY	DATE	NTS	INCH	TITLE <b>RB" SERIES OF RETRACTORS</b> ----- <b>MOLEX INCORPORATED</b> DOCUMENT NO. SD-130173-001 SHEET NO. 1 OF 2
		3 PLACES	±	±	RHOTCA	2010/03/25			
		2 PLACES	±	±	CHECKED BY	DATE			
1 PLACE	±	±	DT	2010/03/25					
		ANGULAR ±1°		APPROVED BY	DATE				
DRAFT WHERE APPLICABLE MUST REMAIN WITHIN DIMENSIONS				DTTUS	2010/03/31				
				MATERIAL NO.	SEE TABLE				
				SIZE	B				
				THIS DRAWING CONTAINS INFORMATION THAT IS PROPRIETARY TO MOLEX INCORPORATED AND SHOULD NOT BE USED WITHOUT WRITTEN PERMISSION					

10 9 8 7 6 5 4 3 2 1

Material Number:	Engineering Number:	Description:	Weight Range in (KG):	Cable Travel in (M):	Weight Range in (LB):	Cable Travel in (FT):	Color:
1301730036	RB2	RB2 RETRACTOR [0-2LB/0-0.9KG], 5.2FT	0 - 0.9	1.6	0 - 2.0	5.2	PUTTY
1301730048	RB4	RB4 RETRACTOR [2-4LB/0.9-1.8KG], 5.2FT	0.9 - 1.8	1.6	2.0-4.0	5.2	PUTTY
1301730043	RB2SC	RB2 RETRACTOR WITH SAFETY CHAIN	0 - 0.9	1.6	0 - 2.0	5.2	PUTTY
1301730050	RB4SC	RB4 RETRACTOR WITH SAFETY CHAIN	0.9 - 1.8	1.6	2.0-4.0	5.2	PUTTY
1301730037	RB210	RB210 RETRACTOR [0-2LB/0-0.9KG], 10FT	0 - 0.9	3.04	0 - 2.0	10.0	PUTTY

RELEASE TO GSM EC NO: WNA2010-0605 DRAWN: RHOTCA 2010/03/25 CHECKED: DT APPROVED: DTTUS 2010/03/31 REV: A	QUALITY SYMBOLS  = 0  = 0.25	GENERAL TOLERANCES (UNLESS SPECIFIED)		DIMENSION STYLE IN/MM	SCALE NTS	DESIGN UNITS INCH	 THIRD ANGLE PROJECTION		
		4 PLACES ±- ±-	3 PLACES ±- ±-	2 PLACES ±- ±-	1 PLACE ±- ±-	DRAWN BY <b>RHOTCA</b>	DATE <b>2010/03/25</b>	TITLE <b>RB" SERIES OF RETRACTORS</b>	
		ANGULAR ±1°				CHECKED BY <b>DT</b>	DATE <b>2010/03/25</b>	MOLEX INCORPORATED	
		DRAFT WHERE APPLICABLE MUST REMAIN WITHIN DIMENSIONS				APPROVED BY <b>DTTUS</b>	DATE <b>2010/03/31</b>	MATERIAL NO. <b>SEE TABLE</b>	DOCUMENT NO. <b>SD-130173-001</b>
				SIZE <b>B</b>	THIS DRAWING CONTAINS INFORMATION THAT IS PROPRIETARY TO MOLEX INCORPORATED AND SHOULD NOT BE USED WITHOUT WRITTEN PERMISSION			SHEET NO. <b>2 OF 2</b>	