

3,464" x 3,464" x 0,984" 88 x 88 x 25 mm

110VU

ETRI®

400 Hz Fans

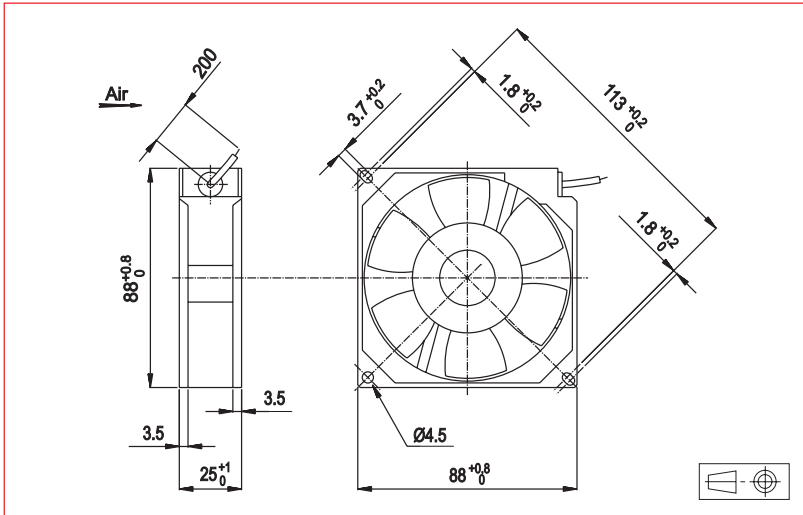

Approvals

NATO codification

Life expectancy

L-10 LIFE AT 40°C:
35 000 hours

400 Hz Motor

Housing material: aluminium
Impeller material: plastic
Weight: 200 g
Bearing system: ball bearings

Connection: flying leads
Electrical protection: impedance protected

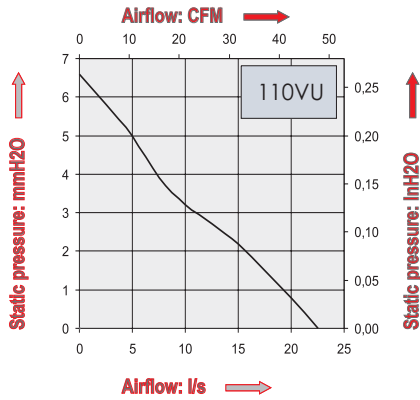

Part Number	Nominal voltage	Airflow	Noise level	Nominal speed	Phases	Capacitor	Input power	Nominal Current	Starting Current	Operating temperature	
	V	l/s	dB(A)	RPM		(not included) µF	W	mA	mA	Min.°C	Max.°C
110VU0162001	15	22,5	43	3300	1	0,47	14	130	140	-10	70
110VU0160001	200	22,5	43	3300	1	0,15	14	75	80	-10	70

Additional versions:

Salt spray protected - Shock and vibration protected - Marine specifications
Wide temperature range

