

FLAT CHIP RESISTOR ARRAY

- Manufactured to Type RM Standards
- Marked with Resistance Value
- Less Board Space than Individual Chips
- Isolated Resistor Elements

SIZE CODE	L	W	C	d	t	a (ref.)	b (ref.)	p (ref.)
1E2	0.039 ± 0.004 1.0±0.1	0.039 ± 0.004 1.0±0.1	0.006 ± 0.004 0.15±0.1	0.012 0.33 max	0.014 ± 0.004 0.35±0.1	0.020 0.5	0.006 0.15	0.026 0.65
1J4	0.126 ± 0.008 3.2±0.2	0.063 ± 0.008 1.6±0.2	0.012 ± 0.008 0.3±0.2	0.016 ± 0.006 0.4±0.15	0.024 ± 0.004 0.6±0.1			0.031 0.8
1J8	0.252 ± 0.008 6.4±0.2							
2A4	0.2 ± 0.008 5.08±0.2	0.079 ± 0.008 2.0±0.2	0.016 ± 0.012 0.4±0.3	0.022 ± 0.006 0.55±0.15	0.024 ± 0.004 0.6±0.1	0.031 0.8	0.050 1.27	
2A8	0.4 ± 0.008 10.16±0.2							
2B4	0.2 ± 0.008 5.08±0.2	0.126 ± 0.008 3.2±0.2	0.020 ± 0.012 0.5±0.3	0.022 ± 0.006 0.55±0.15	0.024 ± 0.004 0.6±0.1	0.031 0.8	0.050 1.27	
2B8	0.4 ± 0.008 10.16±0.2							

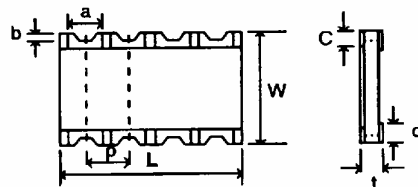

CIRCUIT CONSTRUCTION

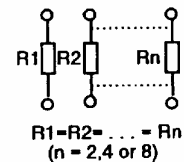

STANDARD APPLICATIONS

TYPE	Power Rating @ 70°C (per element)	TCR (ppm/°C) max.	Resistance Range (E-24 values)	Resistance Tolerance	Absolute Maximum Working Voltage	Maximum Overload Voltage (5 secs. max.)	Operating Temperature Range
CN1E	63mW	±300	10 Ω - 1 MΩ	J (±5%)	25V	50V	-55 - +125°C
CN1J					50V	100V	-55 - +125°C
CN2A	100mW				100V	200V	
CN2B	125mW				200V	400V	

ORDERING & SPECIFYING INFORMATION

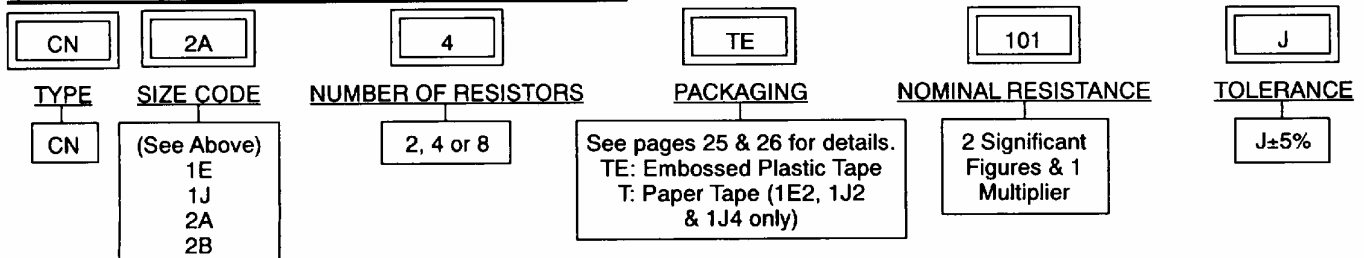

PACKAGING SPECIFICATIONS

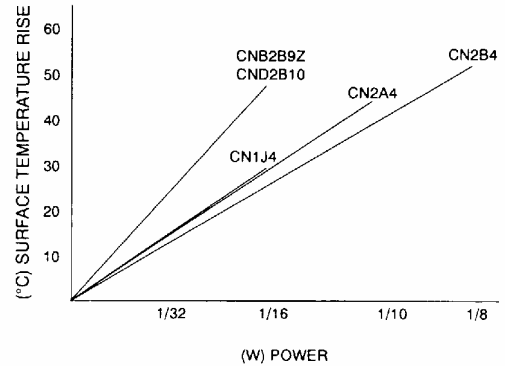
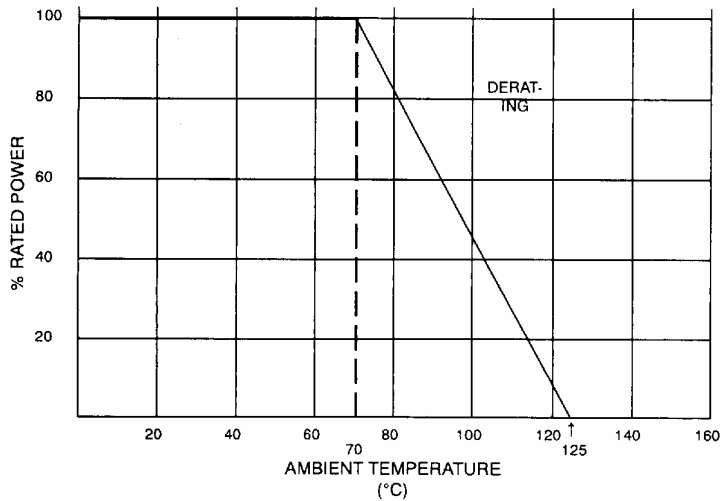

PARAMETER	MAXIMUM DELTA R	TEST METHOD
Thermal Shock	±(1% ± 0.1Ω)	MIL-STD-202F, Method 107D -55°C ~ +125°C, 5 cycles
Low Temperature Operation	±(1% + 0.1Ω)	MIL - R - 55342D π 4.7.4 1 Hour @ -55°C followed by 45 minutes of RCWV**
High Temperature Exposure	±(1% + 0.1Ω)	MIL - R - 55342D π 4.7.6 100 Hours @ 125°C
Short Time Overload	±(2.0% + 0.05Ω)	MIL - R - 55342D π 4.7.5 2.5 X RCWV* for 5 seconds
Resistance to Solder Heat	±(1% + 0.1Ω)	MIL - R - 55342D π 4.7.7 260°C for 10 seconds
Terminal Strength-Push	±(1% + 0.1 Ω)	1.2 Kg for 1 minute
Terminal Strength-Bend	±(0.5% + 0.05 Ω)	5mm Deflection in Either Direction for 10 Seconds
Moisture Resistance	±5%	MIL - STD - 202F, Method 106E 10 Cycles, 240 Hours
Life	±5%	MIL - STD - 202F, Method 108A 70°C, 1000 Hours @ RCWV*, 1.5 Hr ON, 0.5 Hr OFF
Pulse	±5%	2.5 X RCWV*, Not Exceeding Maximum Overload Voltage, 1 Second ON, 25 seconds OFF 10,000 Cycles
Temperature Cycling	±1.0%	30 Minutes @ -55°C; 15 Minutes at +25°C, 30 Minutes at +125°C, 15 Minutes at +25°C, 5 Cycles
Terminal Adhesion	15 Grams, Minimum	Axial Pull, One Terminal at a Time
Dielectric Withstanding Voltage		
CN1J	100V	
CN2A	200V	
CN2B	400V	
CNB & CND	100V	
Insulation Resistance	10,000 Meg Ohm	

*RCWV = Rated Continuous Working Voltage

PACKING SPECIFICATIONS

PART	TD:PUNCHED PAPER	TE: EMBOSSED PLASTC	BULK	STICK PACK
CR2B	5000/10000	4000/10000	1000	-----
CN1J2	5000	-----	-----	-----
CNAJ4	5000	-----	-----	-----
CN1J8	-----	4000	-----	-----
CN2A2	-----	4000	-----	-----
CN2A4	-----	4000	-----	-----
CN2A8	-----	4000	-----	-----
CN2B2	-----	4000*	-----	-----
CN2B4	-----	2000	-----	-----
CN2B8	-----	2000	-----	-----
CNB2E5Z	-----	4000	-----	-----
CNB2B9Z	-----	4000	-----	-----
CND2B10	-----	4000	-----	-----
HM16	-----	2000	-----	50
HN16	-----	2000	-----	50

*Also available on 330mm (13") reel with 7500 pcs.

PACKAGING SPECIFICATIONS

CARRIER TAPE

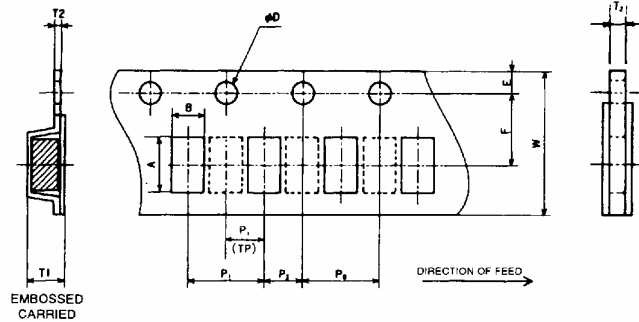

DIMENSIONS (mm)

PACKAGING	SIZE CODE	A	B	W	E	F	T1	T2	P0	P1	P2	ØD
(T) PAPER TAPE	CR2B	3.5±0.1	1.9±0.1	8.0±0.2	1.75±0.1	3.5±0.05	----	0.45±0.1	4.0±0.1	2.0±0.05	2.0±0.05	1.5+0.1 -0
	CN1J2	1.9±0.1	"	"	"	"	----	0.6±0.05	"	----	"	"
	CN1J4	3.5±0.1	"	"	"	"	----	0.75±0.1	"	4.0±0.1	"	"
(TE) EMBOSSED PLASTIC	CR2B	3.5±0.1	1.9±0.2	12.0±0.3	"	"	1.0±0.1	"	"	"	"	"
	CN1J8	6.9±0.1	2.0±0.1	"	"	5.5±0.05	1.0 MAX	0.30±0.1	"	4.0±0.1	2.0±0.05	"
	CN2A2	2.95±0.1	2.4±0.1	8.0±0.2	"	3.5±0.05	"	"	"	"	"	"
	CN2A4	5.4±0.1	"	12.0±0.3	"	5.5±0.05	"	"	"	"	"	"
	CN2A8	10.5±0.1	"	16.0±0.3	"	7.5±0.1	"	0.25±0.1	"	"	2.0±0.1	"
	CN2B2	2.95±0.1	3.6±0.1	8.0±0.2	"	3.5±0.05	"	"	"	8.0±0.1	2.0±0.05	"
	CN2B4	5.45±0.1	"	12.0±0.3	"	5.5±0.05	"	0.3±0.1	"	"	"	"
	CN2B8	10.5±0.1	"	16.0±0.3	"	7.5±0.1	"	"	"	"	2.0±0.1	"
	HM16 HN16	11.6±0.1	8.2±0.1	24.0±0.3	"	11.5±0.1	2.6±0.1	0.4±0.05	"	12.0±0.1	----	"

REEL SPECIFICATIONS

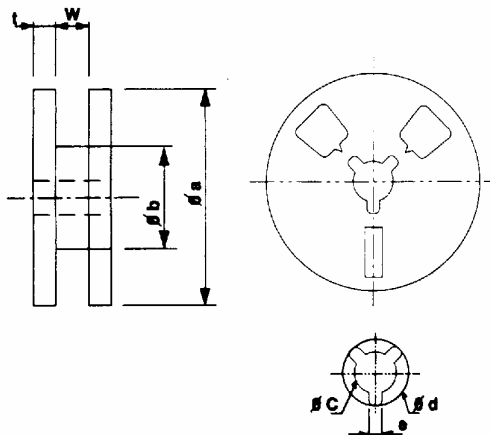

SIZE CODE	DIMENSION (mm)						
	Øa	Øb	w	t	Øc	Ød	e
CR2B							
CN1J2							
CN1J4	178±2.0	80±2.0	10±1.0	1.5±.05	13±0.5	27±20	3.0±0.5
CN2A2							
CN2B2							
CN1J8	"	"	14±1.0	"	"	"	"
CN2A4							
CN2B4							
CN2A8	"	60±2.0	16.4 +2 -0	"	"	21±2.0	2.0 +0.5 -0
CN2B8							
HM16	330±2.0	"	25.5±1.0	"	"	23±1.0	2.0 +0.5 -0
HN16							