

UNIVERSAL FLOW TRANSMITTER MODEL UFT-1

DESCRIPTION

The **Model UFT-1 Universal Flow Transmitter** is a solid-state, digital signal converter designed to operate with Data Industrial 200 Series flow sensors. Both analog (4-20 mA) and pulse outputs are available. The **Model UFT-1** may be mounted in an optional NEMA 4X enclosure or with digital display of gpm or totalized flow (in a non-watertight enclosure).

FEATURES

- **Analog and pulse outputs**
- **Optional watertight (NEMA 4X) enclosure**
- **Optional displays for flow rate and totalization**
- **Low cost**
- **Excitation voltage for flow sensors**
- **LED indication of pulse activity**

APPLICATION

Analog Output (rate)

The **Model UFT-1** analog transmitter converts a Data Industrial digital flow signal into a precalibrated 4-20 mA signal. It must be calibrated for each Data Industrial flow sensor installation. The pipe type, size, and maximum flow rate must be specified at the time of order if 4-20 mA output is to be used.

Pulse Output (totalization)

The **Model UFT-1** pulse output divides the Data Industrial digital flow signal by a jumper-selectable 10 or 100 position to provide a more usable digital pulse. The pulse output is normally used where flow totalization is required. A simple conversion formula, using the flow factors for Data Industrial flow sensors on the next page, can convert the digital pulses to totalized gallons.

The pulse output is an optoisolated transistor switch that can be wired to source or sink pulses to totalizer equipment.

Note: This unit is not intended for field setup or field calibration.



UFT-1



UFT-1E-1

DIMENSIONS

in
(cm)

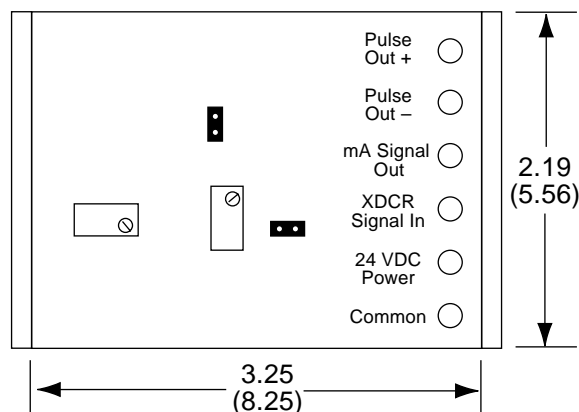

SPECIFICATIONS

Supply voltage	24 VDC @ 60 mA	Max loop resistance	4-20 mA output 750Ω @ 24 VDC
Operating temp	32° to 140°F (0° to 60°C)	Output switch rating	40 VDC @ 200 mA
Operating humidity	5% to 95% noncondensing	Accuracy	±0.5%
Output	4-20 mA and solid-state switch	Step response	5 sec from 10% to 90%
Input	15-150 Hz full scale (dry or electronic contact)		

UNIVERSAL FLOW TRANSMITTER MODEL UFT-1

WIRING

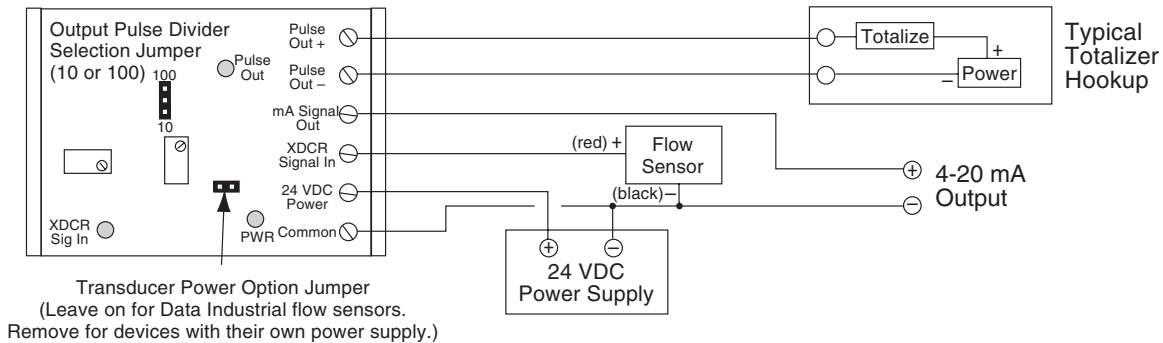

INSTALLATION AND CALIBRATION

The **UFT-1** transmitter can be mounted in any position. The optional watertight enclosure provides a watertight seal against contaminants. While field calibration is not required with the **UFT-1**, flow conversion must be accomplished at the monitoring computer. The information below is provided for making the conversion calculations.

FLOW RATE

$$\text{Flow (gpm)} = \frac{(\text{mA measured} - 4 \text{ mA}) \times \text{Maximum gpm}}{16}$$

Maximum gpm is the flow rate at 20 mA output on the transmitter and must be specified at the time the **UFT-1** is ordered for proper calibration.

TOTALIZED FLOW

$$\text{Totalized Gallons} = (\text{Flow Factor}) \times (\text{Output Divider}) \times (\text{Total Pulses})$$

For totalized m³, multiply the above by 0.00379.

Output Divider = 10 or 100 depending on jumper-selection.
Flow factors per pulse are shown in the table at the right.

TABLE 1. FLOW FACTORS FOR DATA INDUSTRIAL FLOW SENSORS

MODEL	PIPE SIZE in (cm)	FLOW FACTOR	GALLONS/PULSE	
			JUMPER IN 10 POSITION	JUMPER IN 100 POSITION
228PV-1.5	1-1/2 (3.81)	0.03118	0.3118	3.118
228PV-2	2 (5.08)	0.04611	0.4611	4.611
228B-2	2 (5.08)	0.04579	0.4579	4.579
* 228C-2	2 (5.08)	0.04731	0.4731	4.731
250B-0.5	1/2 (1.27)	0.005646	0.05646	0.5646
250B-0.75	3/4 (1.91)	0.007514	0.07514	0.7514
250B-1	1 (2.54)	0.007015	0.07015	0.7015
250B-1.25	1-1/4 (3.18)	0.01280	0.1280	1.280
250B-1.5	1-1/2 (3.81)	0.01780	0.1780	1.780
220B-2.5	2-1/2 (6.35)	0.03800	0.3800	3.800
220B	3 (7.62)	0.07280	0.7280	7.280
220B	4 (10.16)	0.1396	1.396	13.96
220B	5 (12.7)	0.2457	2.457	24.57
220B	6 (15.24)	0.3611	3.611	36.11
220B	8 (20.32)	0.6710	6.710	67.10
220B	10 (25.40)	1.080	10.80	108.0
220B	12 (30.48)	1.630	16.30	163.0
220B	14 (35.56)	1.944	19.44	194.4
220B	16 (40.64)	2.502	25.02	250.2
220B	18 (45.72)	3.158	31.58	315.8

Notes

- Flow factors for a **Model 225** and **226** are the same as **Model 220**.
- Flow factor for **Model 228S** is the same as **228C**.
- PV Series** is sized for SCH 80 PVC pipe.
All other series are sized for SCH 40 black iron pipe.

ORDERING INFORMATION

MODEL	DESCRIPTION
UFT-1	Universal Flow Transmitter Pulse Output Only
UFT-1A	Universal Flow Transmitter with Pulse and Calibrated 4-20 mA Output*
UFT-1E	Universal Flow Transmitter Pulse Output in NEMA 4X Enclosure
UFT-1AE	Universal Flow Transmitter with Pulse and Calibrated 4-20 mA Output* in NEMA 4X Enclosure
DISPLAY OPTION (enclosed models only)	
1	Flow totalization only
2	Flow rate only
3	Flow totalization and flow rate **

UFT-1 - **1** **Example:** **UFT-1A-E-2** Basic transmitter with calibrated 4-20 mA flow rate output (4 mA = no flow 20 mA = max flow), enclosed with LCD flow rate indication

* Pipe size and schedule and maximum flow rate must be specified at time of order.

** When a **UFT-1AE3** is ordered the **UFT-1A** will be in one enclosure and the **Totalizer** and **Rate Display** will be in a separate enclosure.