

SD161

Sega Paddle Controller With Turbo Function

Features

- Power supply range: 3.5V to 5.5V.
- Low power consumption.
- Built in RC oscillator.
- Turbo speed selection: 6Hz & 12Hz & 24Hz .
- Turbo priority function.

General Description

The SD161 is used in SEGA joystick, it can be replace the traditional joystick (with CMOS 4096 resistor 2 pieces, 2 capacitors, 1 series resistor). Additional, it

has the turbo function with 4 selections speed and one slow motion function.

Pin Description

Pin No.	Symbol	Description
1	VSS	System negative power supply.
2	UP	Joystick up signal input.
3	DN	Joystick down signal input.
4	R	Joystick right signal input.
5	L	Joystick left signal input.
6	STR	Joystick start signal input.
7	FH	24Hz frequency output, slow motion can use.
8	SINK	Sinking Ground.
9	A	Joystick A signal input.
10	FM	12Hz frequency output.
11	FL	6Hz frequency output.
12	B	Joystick B signal input.
13	C	Joystick C signal input.
14	SCAN	System Scan pin.
15	VDD	System positive power supply.
16	D1	Right data output.
17	D2	Left data output.
18	D3	A or B data output.
19	D4	Start or C data output.

Absolute Maximum Ratings

RATING	VALUE
DC Supply Voltage	< 5.5V
Input/Output Voltage	VSS-0.5V to VDD+0.5V
Operating Temperature	0° C to 50° C
Storage Temperature	0° C to 70° C

Notice: Stress greater than those listed under **Absolute Maximum Ratings** may cause permanent damage to the device. This is a stress rating only and functional operation of the device at these or any other conditions above those indicated in the operational sections of this specification is not implied. Exposure to absolute maximum rating conditions for extended period may affect reliability.

Electrical Characteristics

(VDD = 5.0V, VSS = 0V, Ta = 25°C, unless otherwise specified)

Parameter	Symbol	Min.	Typ.	Max.	Condition
Operating Voltage	Vdd	3.5V	5V	5.5V	---
Operating Current	Iop	---	1mA	3mA	No load
FL Frequency	F6	5Hz	6Hz	7.5Hz	---
FM Frequency	F12	10Hz	12Hz	15Hz	---
FH Frequency	F24	20Hz	24Hz	30Hz	---

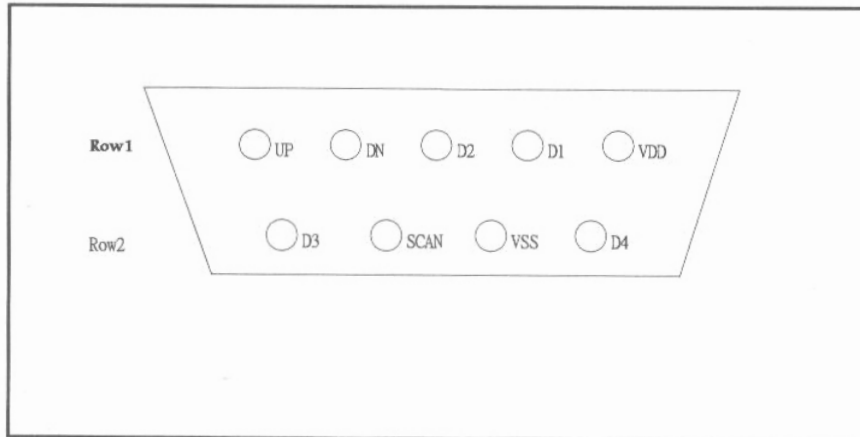
Operating Function
• Sega 9 Pin D-type Connector Assignment

Row1	UP	Joystick up signal input.
	DN	Joystick down signal input.
	D2	Joystick left signal input (by scan pin selected).
	D1	Joystick right signal input (by scan pin selected).
	VDD	System positive power supply to joystick.
Row2	D3	Joystick A or B signal input (by scan pin selected).
	SCAN	System supply scan signal.
	VSS	System negative power supply to joystick.
	D4	Joystick start or C signal input (by scan pin selected).

Application circuits

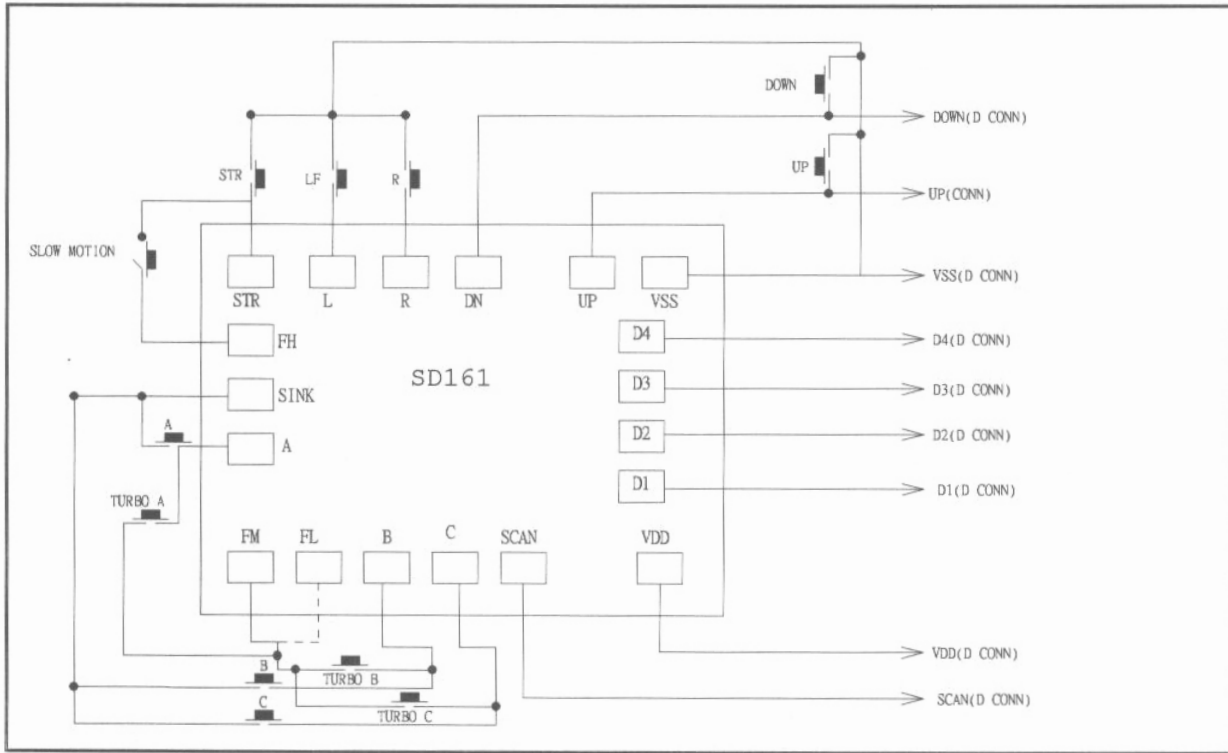

Bonding Diagram

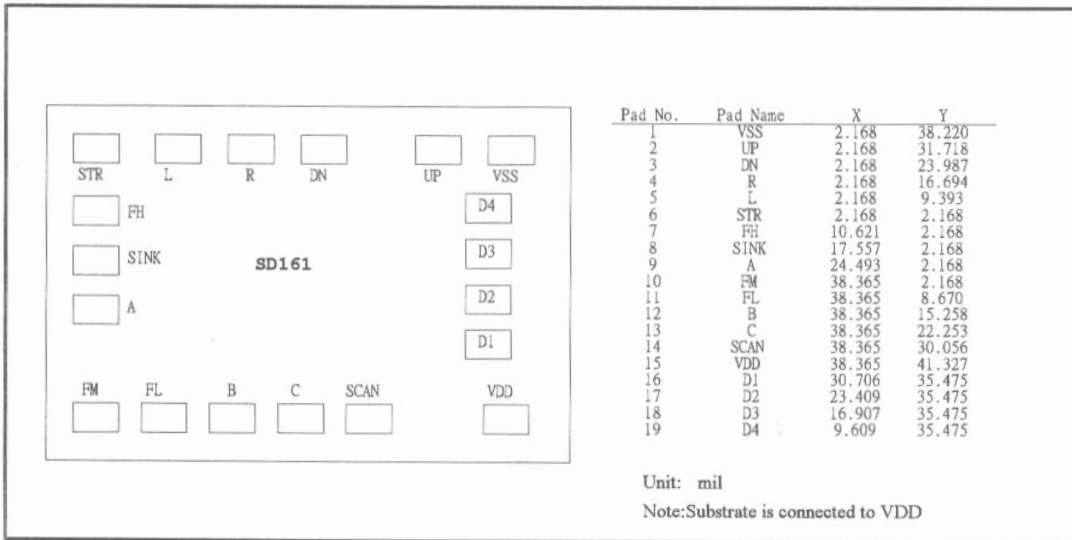

SD163

4 In 1 Super Joystick Controller With Turbo And Auto Functions

Features

- Power supply range: 3.5V to 5.5V
- Built in RC oscillator.
- Used in MEGA-1, MEGA-2, Nintendo, Super Nintendo entertainment system.
- Built in turbo and auto function for setting A, B, C, X, Y and Z keys individually.
- 2 LEDs to display operating of normal, turbo or auto mode.
- Slow motion is available.
- First priority with turbo mode.
- Compatible with Super Nintendo system with European specification.
- Low power consumption.

General Description

SD163 is a new type COMS joystick controller designed for both 8 bits Nintendo, 16 bits Super Nintendo, MEGA-1 and MEGA-2 paddle controllers. It can be implemented into different kinds of

entertainment system with minimum application circuit. This allows for the production of a wide variety of high quality joysticks. The TURBO and AUTO functions are built in SD163 with LED indicated.

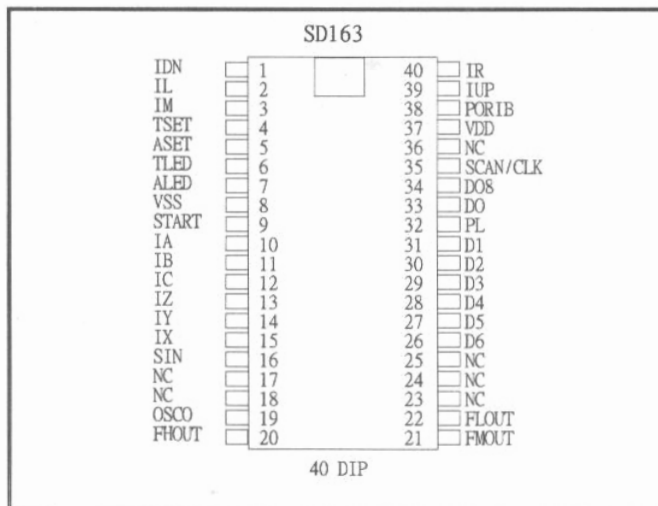
Pin Configuration

Pin Description

Pin No.	Symbol	Description
1	IDN	Down input pin.
2	IL	Left input pin.
3	IM	Mega 1&2 :mode pin.Super Nintendo:scl pin.
4	TSET	Turbo setting pin.
5	ASET	Auto setting pin.

6	TLED	Turbo LED indication pin.
7	ALED	Auto LED indication pin.
8	VSS	Negative power supply.
9	START	Start signal input pin.
10	IA	Mega 1&2:A input pin. Super Nintendo:B input pin.
11	IB	Mega 1&2:B input pin. Super Nintendo:A input pin.
12	IC	Mega 1&2:C input pin. Super Nintendo:TR input pin.
13	IZ	Mega 1&2:Z input pin. Super Nintendo:TL input pin.
14	IY	Mega 1&2:Y input pin. Super Nintendo:X input pin.
15	IX	Mega 1&2:X input pin. Super Nintendo:Y input pin.
16	SIN	On/Off slow motion pin.
19	OSCO	Oscillator output pin.
20	FHOUT	40 Hz frequency output pin.
21	FMOLT	20 Hz frequency output pin.
22	FLOUT	10 Hz frequency output pin.
26	D6	Mega:data output pin.
27	D5	Mega:data output pin.
28	D4	Mega:data output pin.
29	D3	Mega:data output pin.
30	D2	Mega : data output pin.
31	D1	Mega : data output pin.
32	PL	Super Nintendo : preload input pin.
33	DO	Super Nintendo : data output pin.
34	DO8	Nintendo : data output pin.
35	SCAN/CLK	Mega 1&2 : SCAN INPUT; Super Nintendo : CLK input.
37	VDD	Positive power supply.
38	PORIB	Power on reset.
39	IUP	Up input pin.
40	IR	Right input pin.
17,18,23 ,24,25,26	NC	No connection.

Absolute Maximum Ratings

RATING	VALUE
DC Supply Voltage	<5.5V
Input/Output Voltage	VSS-0.5Vto VDD+0.5V
Operating Temperature	0° C to 50° C
Storage Temperature	0° C to 70° C

Notice: Stress greater than those listed under **Absolute Maximum Ratings** may cause permanent damage to the device. This is a stress rating only and functional operation of the device at these or any other conditions above those indicated in the operational sections of this specification is not implied, Exposure to absolute maximum rating conditions for extended period may affect reliability.

Electrical Characteristics

(VDD = 5.0V, VSS = 0V, Ta = 25°C, unless otherwise specified)

Parameter	Symbol	Min.	Typ.	Max.	Condition
Operating Voltage	Vdd	3.5V	5V	5.5V	---
Operating Current	Iop	---	100μA	300μA	No load
FL Frequency	FLOUT	8Hz	10Hz	12Hz	---
FM Frequency	FMOUT	16Hz	20Hz	24Hz	---
FH Frequency	FHOUT	32Hz	40Hz	48Hz	---

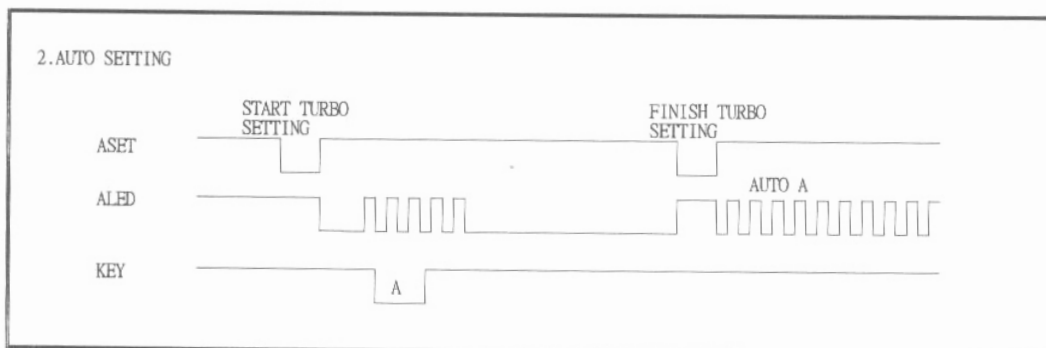
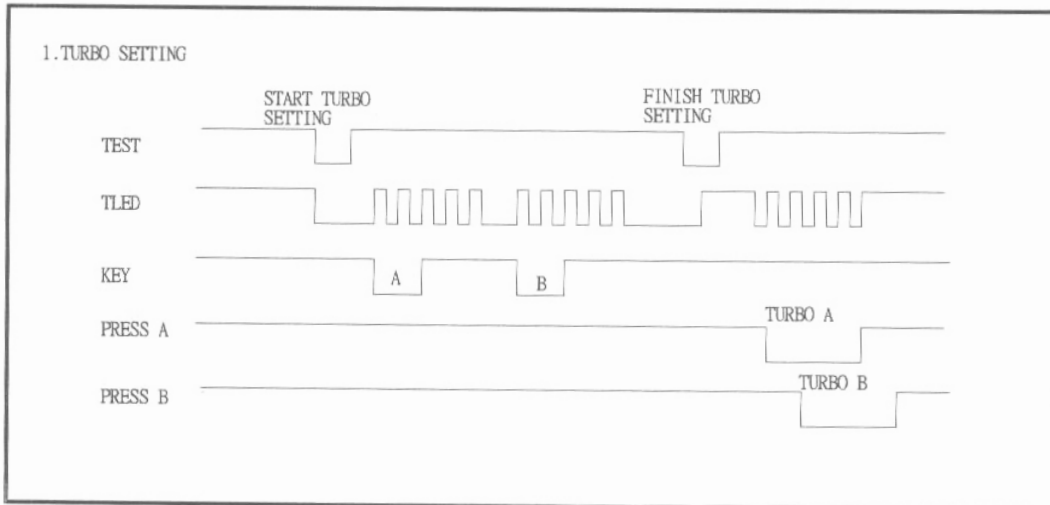
Operating Function

Application circuits

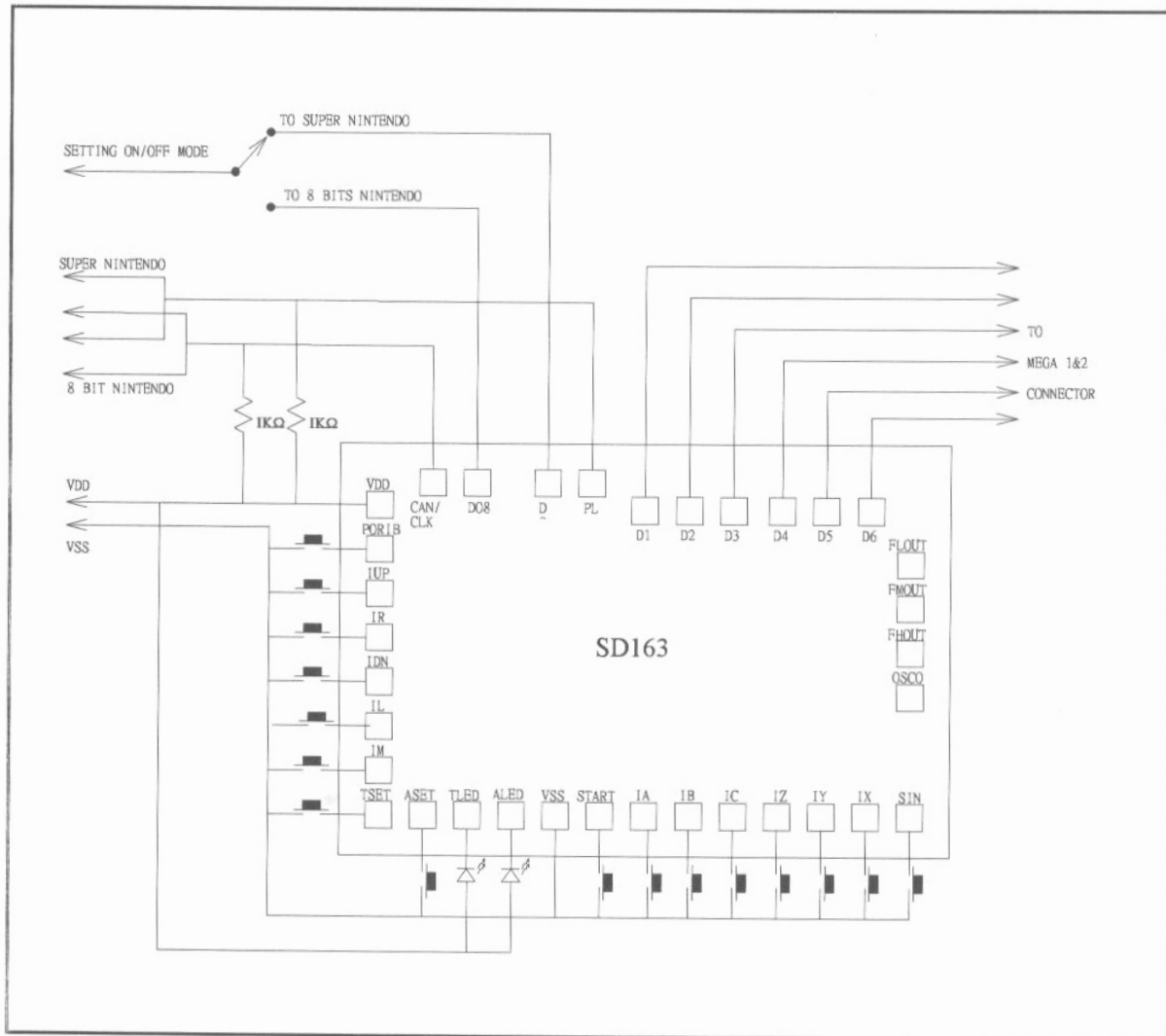

Bonding Diagram

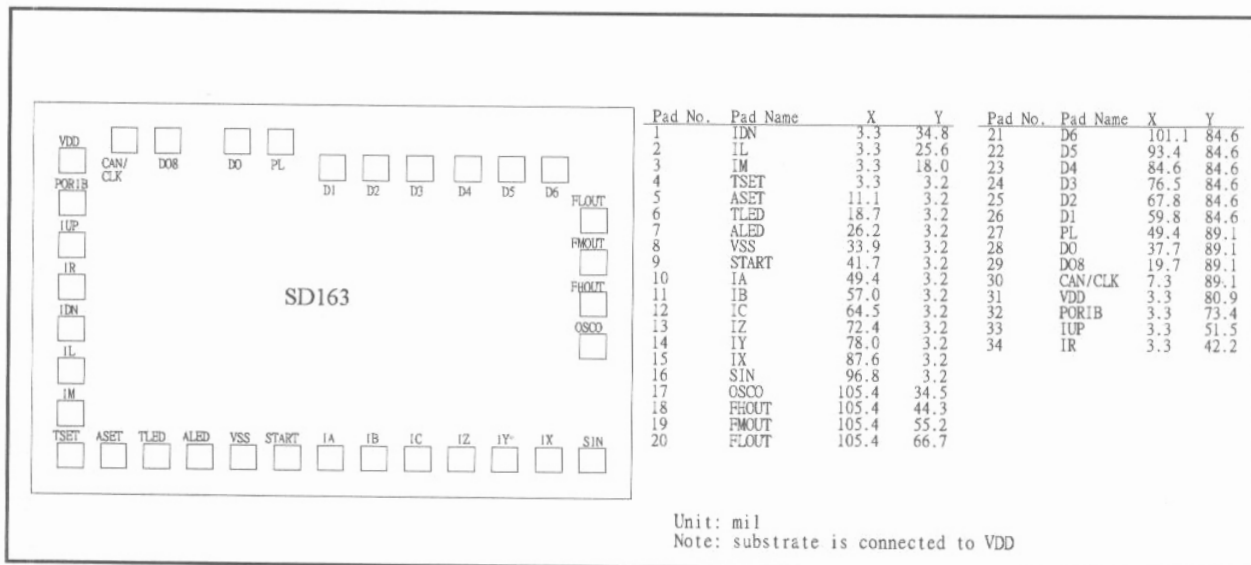

SD165

16 Bit Super Nintendo Paddle Controller With Turbo Function

Features

- Power supply range: 3.5V to 5.5V
- Built in RC oscillator for turbo function.
- On/off and level hold operating modes for turbo function.
- Bonding option for slow motion operation.
- Two kinds of turbo speed for various application (16Hz and 12Hz)
- Low power consumption.

General Description

SD165 is a new type COMS joystick controller designed for 16 bits Super Nintendo paddle controller. Three kinds of turbo speed are available by bonding options.

In various application, only minimum external components is needed.

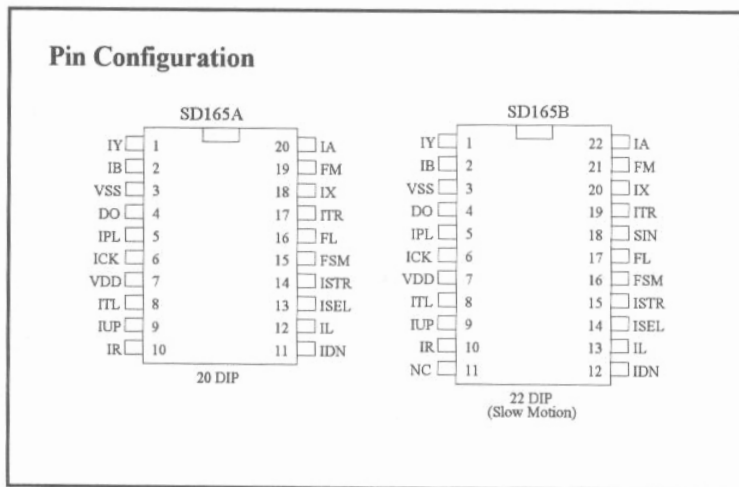
Pin Description

Pin No.	Symbol	Description
1	IY	Y input pin.
2	IB	B input pin.
3	VSS	Negative power supply ; Bonding option for slow motion operation.
4	DO	Data output pin.
5	IPL	Preload input pin.
6	ICK	System clock input.
7	VDD	Positive power supply.
8	ITL	TL input pin.
9	IUP	Up input pin.
10	IR	Right input pin.

11	NC	No connection.
12	IDN	Down input pin.
13	IL	Left input pin.
14	ISEL	SEL input pin.
15	ISTR	Start input pin.
16	FSM	Output of slow motion frequency.
17	FL	6Hz frequency output pin.
18	SIN	Slow motion on/off pin.
19	ITR	TR input pin.
20	IX	X input pin.
21	FM	12Hz frequency output pin.
22	IA	A input pin.

Absolute Maximum Ratings

RATING	VALUE
DC Supply Voltage	<5.5V
Input/Output Voltage	VSS-0.5V to VDD+0.5V
Operating Temperature	0° C to 50° C
Storage Temperature	0° C to 70° C

Notice: Stress greater than those listed under **Absolute Maximum Ratings** may cause permanent damage to the device. This is a stress rating only and functional operation of the device at these or any other conditions above those indicated in the operational sections of this specification is not implied. Exposure to absolute maximum rating conditions for extended period may affect reliability.

Electrical Characteristics

(VDD = 5.0V, VSS = 0V, Ta = 25°C, unless otherwise specified)

Parameter	Symbol	Min.	Typ.	Max.	Condition
Operating Voltage	Vdd	3.5V	5V	5.5V	---
Operating Current	Iop	---	100µA	300µA	No load
FL Frequency	FLOUT	5Hz	6Hz	7Hz	---
FM Frequency	FMOUT	10Hz	12Hz	14Hz	---

Application circuits

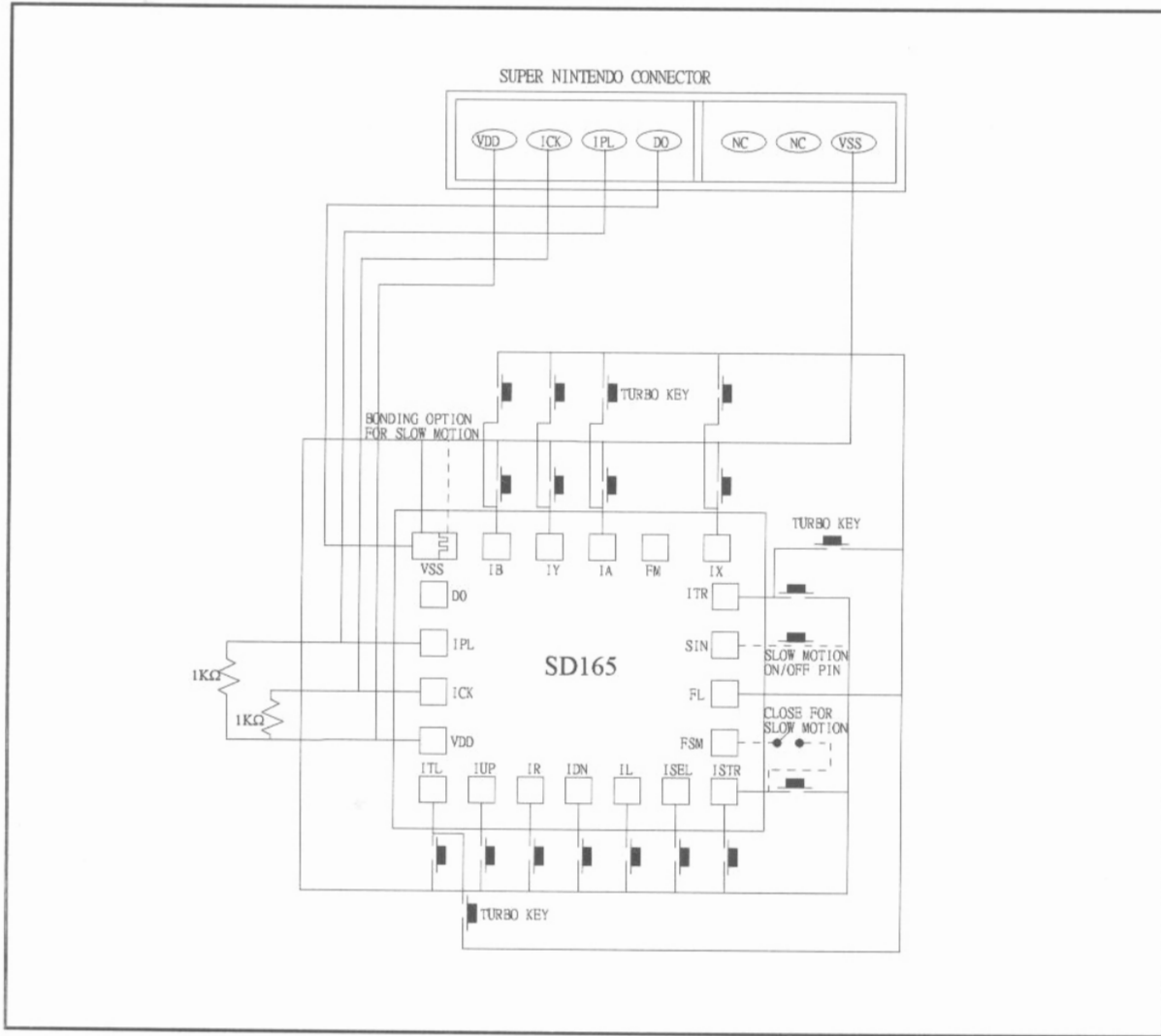

Bonding Diagram

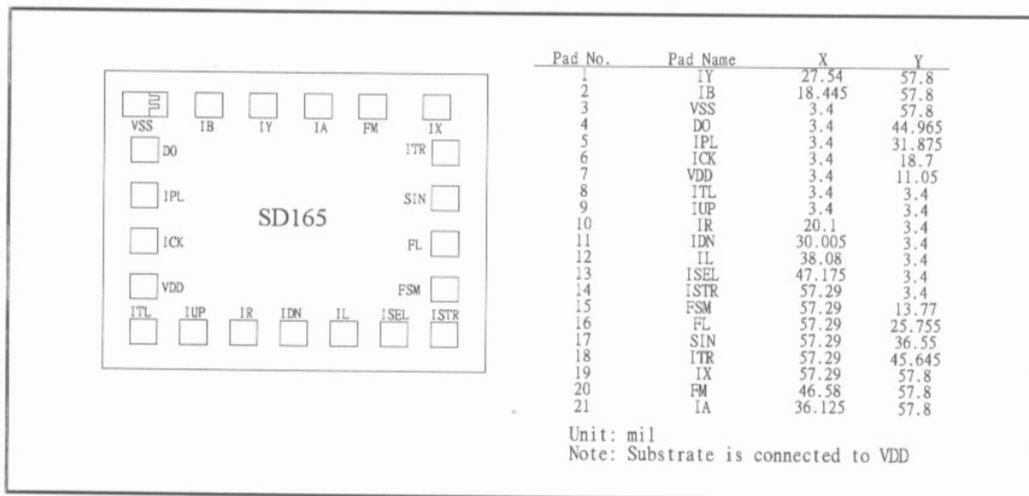

SD166

16 Bits Sega Mega-2 Paddle Controller With Turbo Function

Features

- Power supply range: 3.5V to 5.5V
- Built in RC oscillator for turbo function.
- On/off and level hold operating modes for turbo function.
- Bonding option for slow motion operation.
- Two kinds of turbo speed for various applications (5Hz and 10Hz).
- Low power consumption.

General Description

SD166 is a new type COMS joystick controller designed for 16 bits SEGA MEGA-2 paddle controller. Two kinds of turbo speed are available

by bonding options. In various applications, only minimum external components is needed.

Pin Description

Pin No.	Symbol	Description
1	FM	12Hz frequency output pin.
2	FL	6Hz frequency output pin.
3	OSCO	Oscillator output pin.
4	SIN	Slow motion on/off pin.
5	VSS	Negative power supply. Bonding option for slow motion operation.
6	Q6	Data output pin.
7	Q5	Data output pin.
8	Q4	Data output pin.
9	Q3	Data output pin.
10	Q2	Data output pin.
11	Q1	Data output pin.
12	VDD	Positive power supply.
13	SCAN	Scan signal from MEGA-2 system.
14	PORI	Power on reset pin.
15	IUP	Up input pin.
16	IR	Right input pin.
17	IDN	Down input pin.
18	IL	Left input pin.
19	IST	Start input pin.
20	IA	A input pin.

21	IB	B input pin.
22	IC	C input pin.
23	IZ	Z input pin.
24	IY	Y input pin.
25	IX	X input pin.
26	IMODE	Mode input pin.
27	FSM	Output of slow motion frequency.

Absolute Maximum Ratings

RATING	VALUE
DC Supply Voltage	<5.5V
Input/Output Voltage	VSS-0.5V to VDD+0.5V
Operating Temperature	0° C to 50° C
Storage Temperature	0° C to 70° C

Notice: Stress greater than those listed under **Absolute Maximum Ratings** may cause permanent damage to the device. This is a stress rating only and functional operation of the device at these or any other conditions above those indicated in the operational sections of this specification is not implied. Exposure to absolute maximum rating conditions for extended period may affect reliability.

Electrical Characteristics

(VDD = 5.0V, VSS = 0V, Ta = 25°C, unless otherwise specified)

Parameter	Symbol	Min.	Type.	Max.	Condition
Operating Voltage	Vdd	4.5V	5V	5.5V	---
Operating Current	Iop	---	100µA	300µA	No load
FL Frequency	FL	4Hz	5Hz	6Hz	---
FM Frequency	FM	8Hz	10Hz	12Hz	---

Application circuits

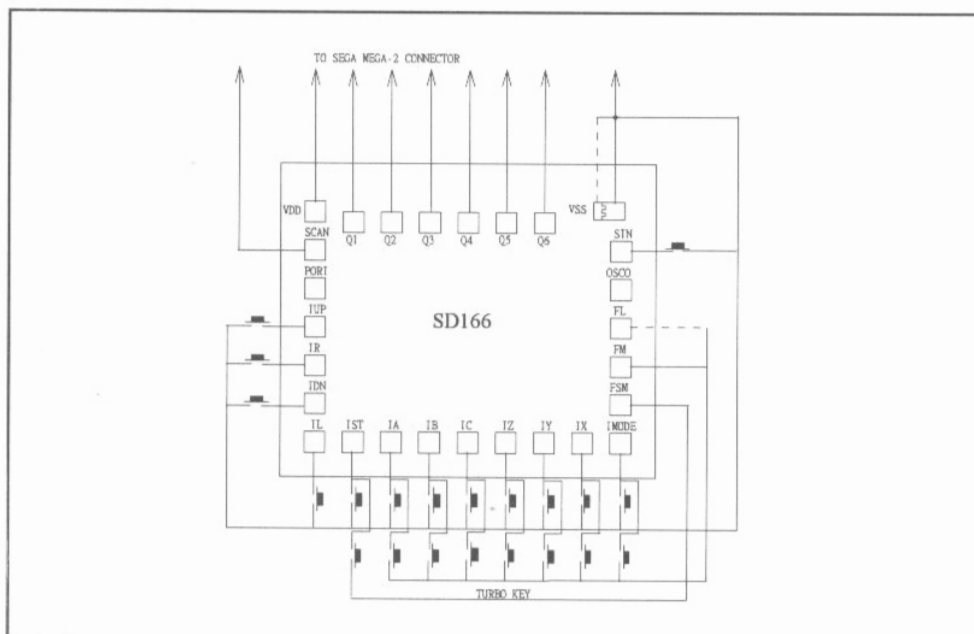

Bonding Diagram
