



M.S.KENNEDY CORP.

# HIGH SPEED, FET INPUT DIFFERENTIAL OP-AMP

# 0032

4707 Dey Road Liverpool, N.Y. 13088

(315) 701-6751

**FEATURES:**

- Fast Slew Rate - 650 V/ $\mu$ S Typ.
- FET Input
- Wide Bandwidth
- Electrically Isolated Case
- Industry Wide Pin Compatible 0032 Upgrade
- DSCC SMD 5962-80013

**MIL-PRF-38534 CERTIFIED**

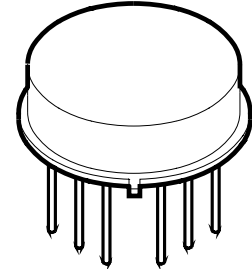

**DESCRIPTION:**

The MSK 0032 is a high speed, FET input, differential amplifier designed to replace the popular LH0032 and TP0032. Since the MSK 0032 requires less compensation than the LH0032, it exhibits wider bandwidth and greater stability. The MSK 0032 can be used as a direct replacement in current designs using the LH0032 or TP0032 with no changes to compensation schemes. High frequency signal transfer circuits such as video amplifiers, high speed integrators and comparators are just a few of the applications that the MSK 0032 is well suited for.

**EQUIVALENT SCHEMATIC**

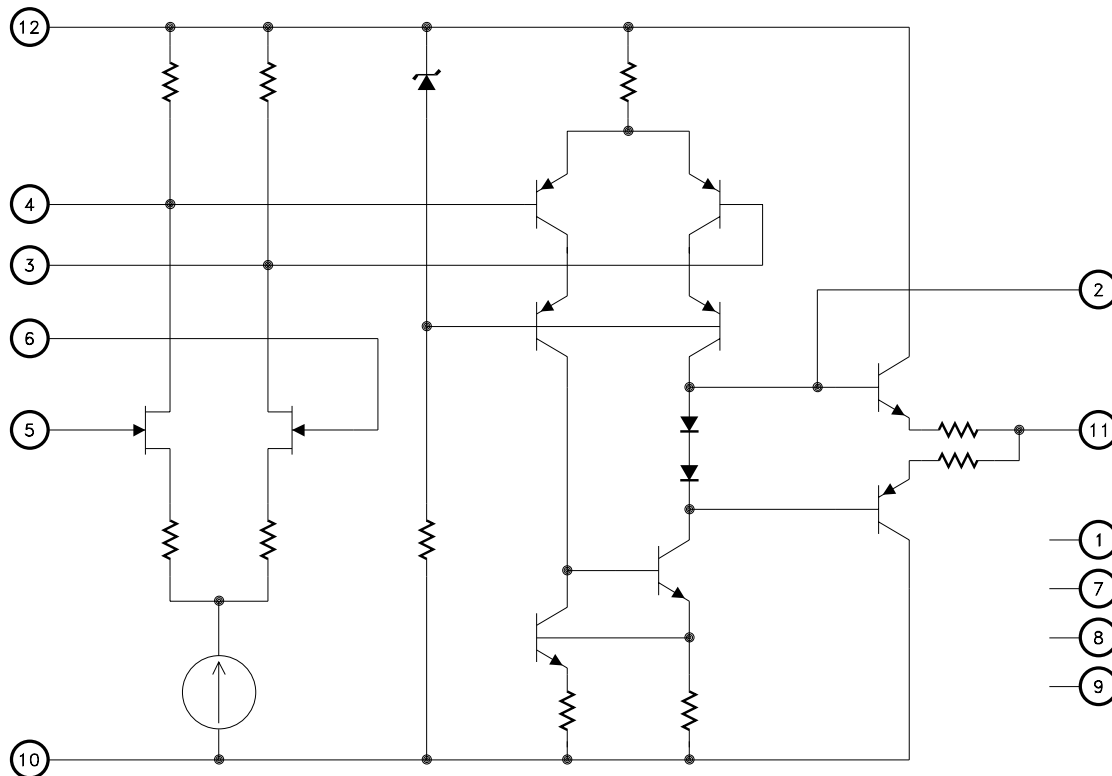

**TYPICAL APPLICATIONS**

- Video Amplifiers
- Comparator Circuits
- High Speed Integrators

**PIN-OUT INFORMATION**

- |                        |                          |
|------------------------|--------------------------|
| 1 No Connection        | 7 No Connection          |
| 2 Output Compensation  | 8 No Connection          |
| 3 Compensation/Balance | 9 No Connection          |
| 4 Compensation/Balance | 10 Negative Power Supply |
| 5 Inverting Input      | 11 Output                |
| 6 Non-Inverting Input  | 12 Positive Power Supply |

## ABSOLUTE MAXIMUM RATINGS

$\pm V_{CC}$	Supply Voltage . . . . .	$\pm 18V$	$T_{ST}$	Storage Temperature Range	$-65^{\circ}C$ to $+150^{\circ}C$
$I_{OUT}$	Output Current . . . . .	$\pm 40mA$	$T_{LD}$	Lead Temperature Range	$300^{\circ}C$ (10 Seconds)
$V_{IN}$	Differential Input Voltage . . . . .	$\pm 30V$	$T_J$	Junction Temperature . . . . .	$175^{\circ}C$
$T_C$	Case Operating Temperature Range (MSK 0032B) . . . . .	$-55^{\circ}C$ to $+125^{\circ}C$ (MSK 0032) . . . . .			
$R_{TH}$	Thermal Resistance . . . . .	$200^{\circ}C/W$			
	Junction to Case Output Devices Only				

## ELECTRICAL SPECIFICATIONS

$\pm V_{CC} = \pm 15V$  Unless Otherwise Specified

Parameter	Test Conditions	Group A Subgroup	MSK 0032B			MSK 0032			Units
			Min.	Typ.	Max.	Min.	Typ.	Max.	
<b>STATIC</b>									
Supply Voltage Range ② ⑦		-	$\pm 10$	$\pm 15$	$\pm 18$	-	$\pm 15$	$\pm 18$	V
Quiescent Current	$V_{IN} = 0V$	1	-	$\pm 15$	$\pm 20$	-	$\pm 15$	$\pm 22$	mA
		2,3	-	$\pm 18$	$\pm 25$	-	-	-	mA
<b>INPUT</b>									
Input Offset Voltage	Bal.Pins = N/C $V_{IN} = 0V$ $A_V = -10V/V$	1	-	$\pm 0.5$	$\pm 5$	-	$\pm 1$	$\pm 7$	mV
Input Offset Voltage Drift	Bal.Pins = N/C $V_{IN} = 0V$	2,3	-	$\pm 10$	$\pm 50$	-	-	-	$\mu V/^{\circ}C$
Input Offset Adjust	$R_{POT} = 10K\Omega$ $T_O = +V_{CC}$	1,2,3	Adjust to Zero			Adjust to Zero			mV
Input Bias Current	$V_{CM} = 0V$ Either Input	1	-	$\pm 10$	$\pm 100$	-	$\pm 25$	$\pm 300$	pA
		2,3	-	$\pm 0.2$	$\pm 50$	-	-	-	nA
Input Offset Current	$V_{CM} = 0V$	1	-	10	25	-	20	100	pA
		2,3	-	0.1	25	-	-	-	nA
Input Impedance ②	$F = DC$	-	-	$10^{12}$	-	-	$10^{12}$	-	$\Omega$
Power Supply Rejection Ratio ②	$\Delta V_{CC} = \pm 15V$	-	50	70	-	45	70	-	dB
Common Mode Rejection Ratio ②	$F = DC$ $V_{CM} = \pm 10V$	-	50	80	-	45	80	-	dB
Input Noise Voltage ②	$F = 10Hz$ To $1MHz$	-	-	1.5	-	-	1.5	-	$\mu V_{rms}$
Equivalent Input Noise ②	$F = 1KHz$	-	-	40	-	-	40	-	$nV/\sqrt{Hz}$
<b>OUTPUT</b>									
Output Voltage Swing	$R_L = 1K\Omega$	4	$\pm 10$	$\pm 12$	-	$\pm 10$	$\pm 12$	-	V
Output Current	$R_L = 1K\Omega$	4	$\pm 10$	$\pm 20$	-	$\pm 10$	$\pm 20$	-	mA
Settling Time to 1% ①	$R_L = 1K\Omega$ $10V$ step	4	-	0.1	0.5	-	0.1	0.5	$\mu S$
Settling Time to 0.1% ①	$R_L = 1K\Omega$ $10V$ step	4	-	300	-	-	300	-	nS
Unity Gain Bandwidth ②	$A_V = +1$	-	-	25	-	-	25	-	MHz
<b>TRANSFER CHARACTERISTICS</b>									
Slew Rate Limit	$V_{OUT} = \pm 10V$ $R_L = 1K\Omega$	4	350	650	-	350	650	-	$V/\mu S$
Open Loop Voltage Gain	$V_{OUT} = \pm 10V$ $F = 100Hz$	4	70	-	-	70	-	-	dB
Small Signal Rise Time	$A_V = +1$ $R_L = 1K\Omega$	4	-	10	20	-	10	20	nS
Small Signal Delay Time	$V_{IN} = 1V$ $R_L = 1K\Omega$	4	-	12	25	-	12	25	nS

### NOTES:

- ①  $A_V = -1$ , measured in false summing junction circuit.
- ② Devices shall be capable of meeting the parameter, but need not be tested. Typical parameters are for reference only.
- ③ Industrial grade devices shall be tested to subgroups 1 and 4 unless otherwise specified.
- ④ Military grade devices ('B' suffix) shall be 100% tested to subgroups 1,2,3 and 4.
- ⑤ Subgroup 5 and 6 testing available upon request.
- ⑥ Subgroup 1,4  $T_A = T_C = +25^{\circ}C$   
Subgroup 2,5  $T_A = T_C = +125^{\circ}C$   
Subgroup 3,6  $T_A = T_C = -55^{\circ}C$
- ⑦ Electrical specifications are derated for power supply voltages other than  $\pm 15VDC$ .

## APPLICATION NOTES

### HEAT SINKING

Since the case of the MSK 0032 only runs approximately 40°C hotter than the ambient temperature, a heat sink is generally not necessary. However, in applications where it is critical to minimize input bias current, a heat sink may be used. The case of the MSK 0032 is isolated from the internal circuitry so the heat sink may be attached directly to the case. The heat sink may however create enough parasitic capacitance at the pins to necessitate adjusting the amount of compensation used.

### INPUT OFFSET VOLTAGE NULL

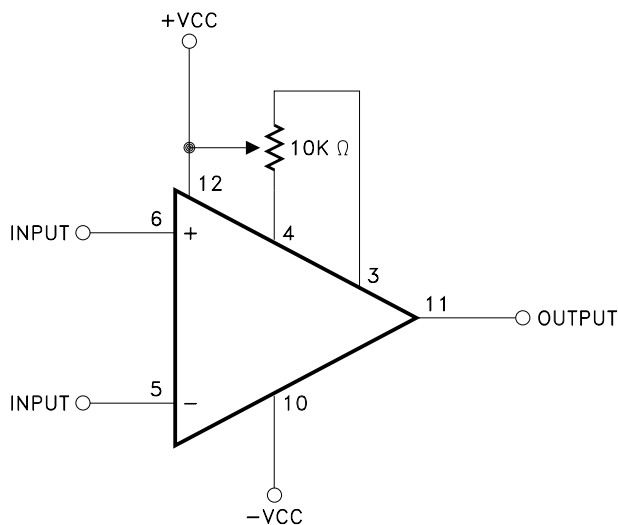

Figure 1

The input offset voltage of the MSK 0032 is typically less than  $\pm 0.5\text{mV}$ . If it is necessary to null the offset to zero or some value other than zero, the above circuit is recommended. Typical offset adjust range is 25mV.

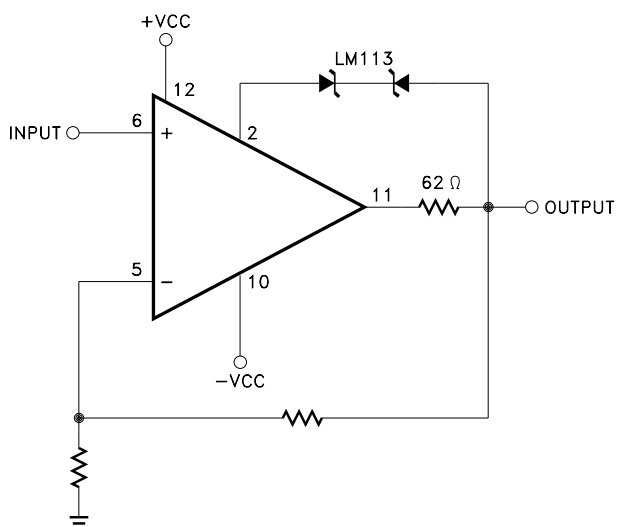

Figure 2  
Output Short Circuit Protection

### COMPENSATION

When replacing an LH0032 or TP0032 with an MSK 0032, no changes in compensation need be made. The MSK 0032 will demonstrate greater loop stability than the LH0032 and loop stability very similar to the TP0032. As with any operational amplifier, a feedback capacitor in the range of 2-10pF is recommended to compensate for the effect of the R-C time constant created by the input capacitance of the op-amp and the feedback and input resistors in an inverting configuration. See Figure 3 and Figure 4 for recommended compensation schemes for non-inverting configurations.

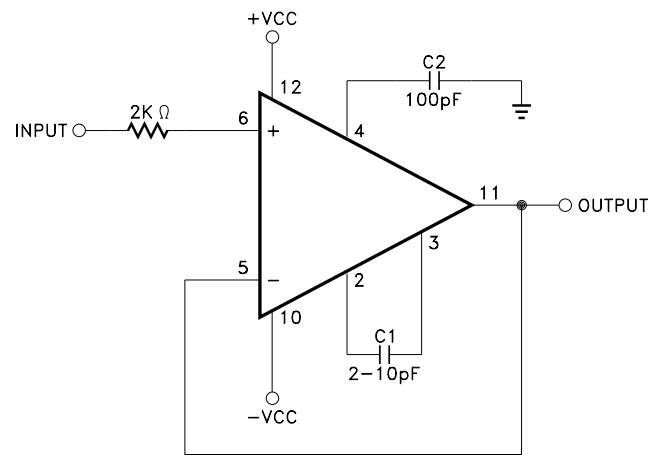

Figure 3

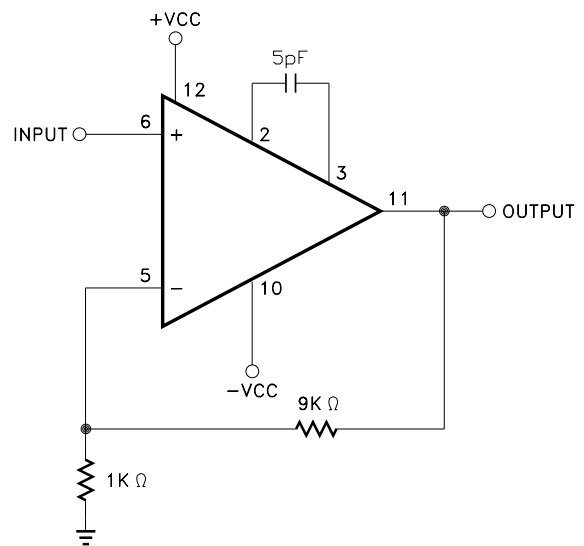
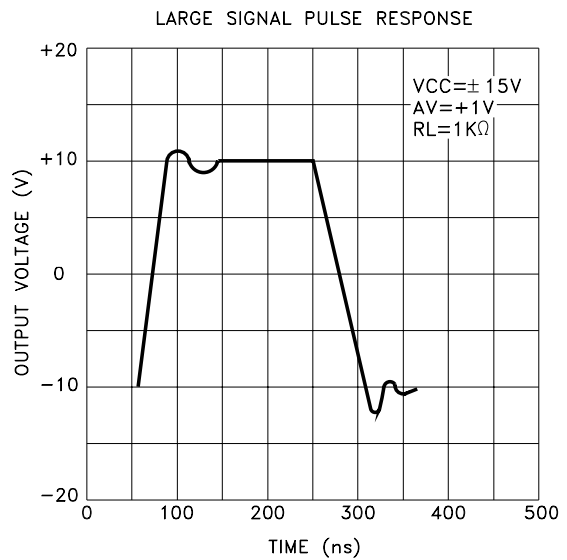
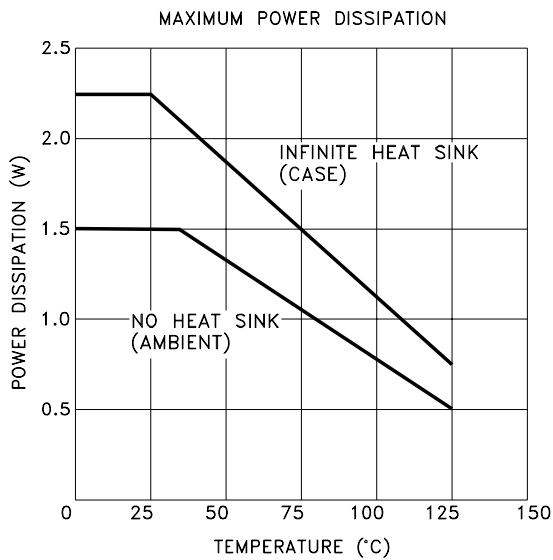
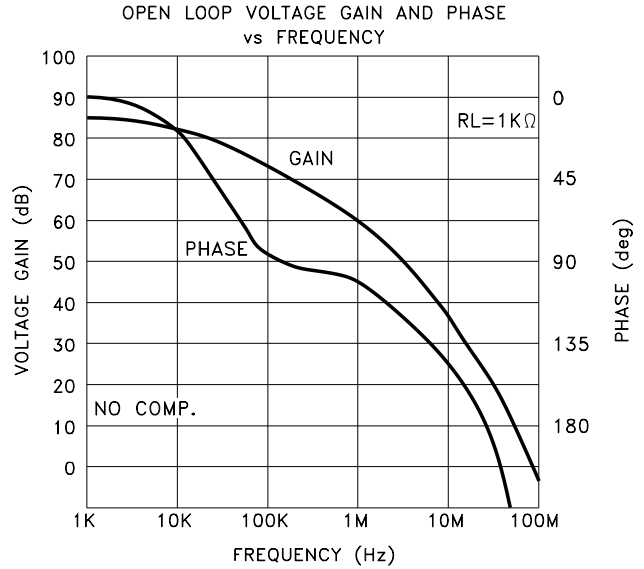
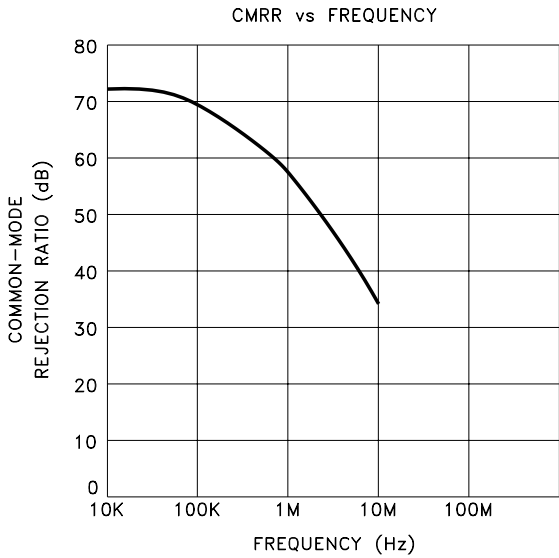
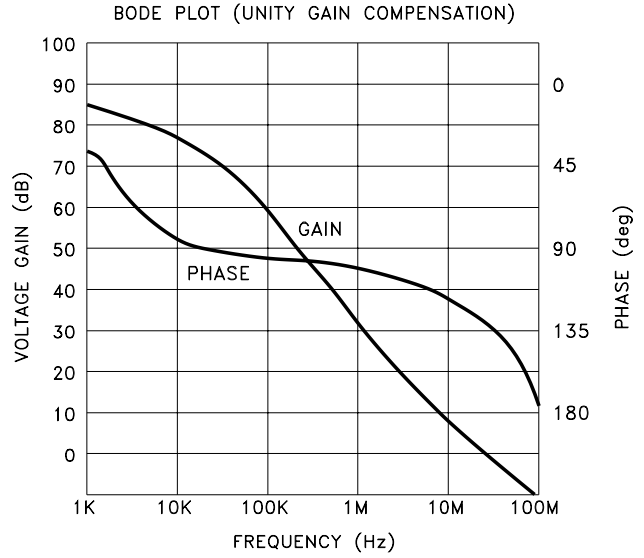
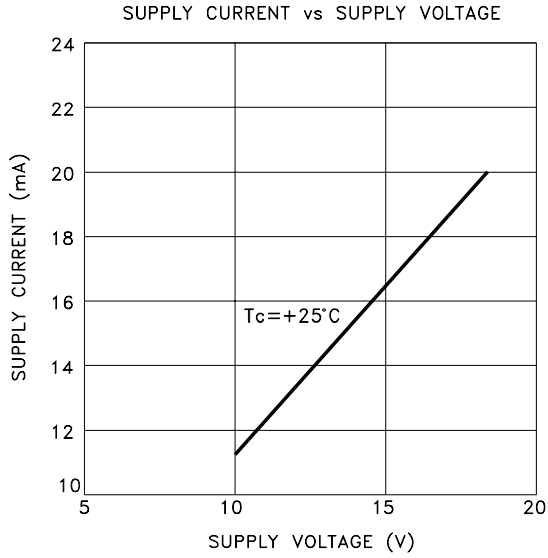

Figure 4

### POWER SUPPLY BYPASSING

Both the negative and the positive power supplies must be effectively decoupled with a high and low frequency bypass circuit to avoid power supply induced oscillation. An effective decoupling scheme consists of a 0.1 microfarad ceramic capacitor in parallel with a 4.7 microfarad tantalum capacitor from each power supply pin to ground.

# TYPICAL PERFORMANCE CURVES



# MECHANICAL SPECIFICATIONS

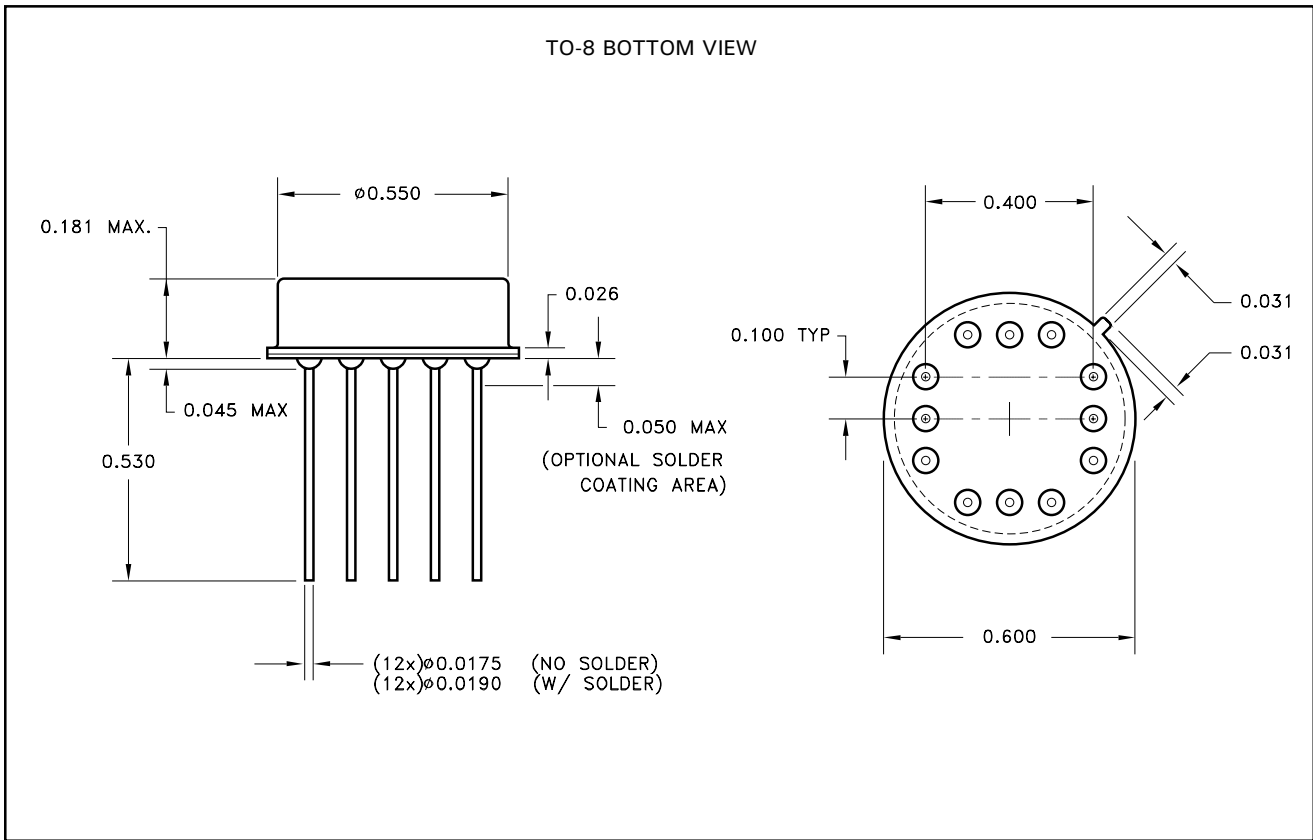

ALL DIMENSIONS ARE  $\pm 0.010$  INCHES UNLESS OTHERWISE LABELED

## ORDERING INFORMATION

Part Number	Screening Level
MSK0032	Industrial
MSK0032B	Military-Mil-PRF-38534
5962-80013	DSCC-SMD

**M.S. Kennedy Corp.**  
 4707 Dey Road, Liverpool, New York 13088  
 Phone (315) 701-6751  
 FAX (315) 701-6752  
[www.mskennedy.com](http://www.mskennedy.com)

The information contained herein is believed to be accurate at the time of printing. MSK reserves the right to make changes to its products or specifications without notice, however, and assumes no liability for the use of its products.