

RoHS Compliant Product
A suffix of "-C" specifies halogen and lead-free

DESCRIPTION

The STT3981 utilized advance processing techniques to achieve the lowest possible on-resistance, extremely efficient and cost-effectiveness device. The STT3981 is universally used for all commercial-industrial applications.

FEATURES

- Low On-Resistance
- Low Gate Charge

PACKAGE DIMENSIONS

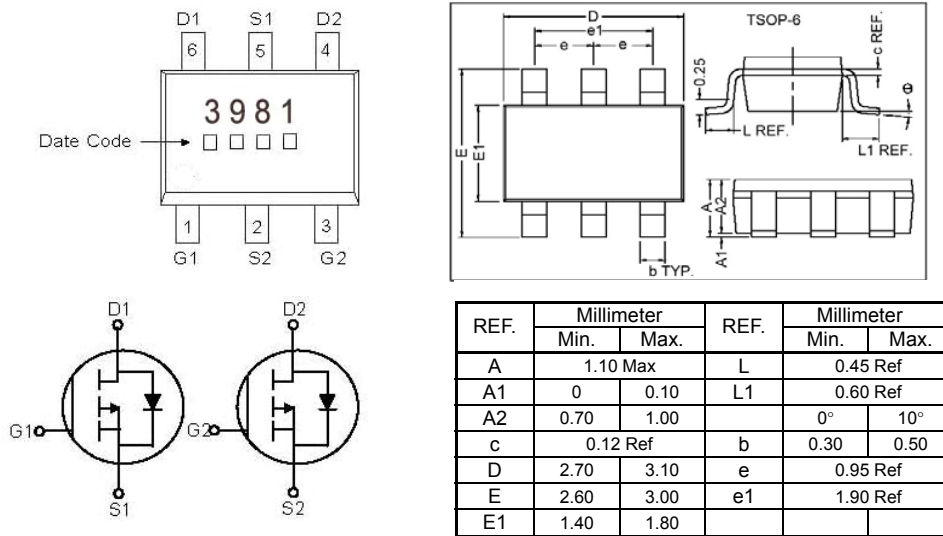

ABSOLUTE MAXIMUM RATINGS

Parameter	Symbol	Ratings	Unit
Drain-Source Voltage	V_{DS}	-20	V
Gate-Source Voltage	V_{GS}	±8	V
Continuous Drain Current ³	$I_D @ T_A=25^\circ C$	-1.6	A
	$I_D @ T_A=70^\circ C$	-1.3	A
Pulsed Drain Current ¹	I_{DM}	-8	A
Power Dissipation	$P_D @ T_A=25^\circ C$	0.8	W
Linear Derating Factor		0.006	W/°C
Operating Junction and Storage Temperature Range	T_J, T_{STG}	-55 ~ +150	°C

THERMAL DATA

Parameter	Symbol	Ratings	Unit
Thermal Resistance Junction-ambient ³ (Max)	$R_{\theta JA}$	150	°C/W

ELECTRICAL CHARACTERISTICS ($T_A = 25^\circ\text{C}$ unless otherwise specified)

Parameter	Symbol	Min	Typ	Max	Unit	Test Conditions
Static						
Drain-Source Breakdown Voltage	BV_{DSS}	-20	-	-	V	$V_{GS} = 0, I_D = 250 \mu\text{A}$
Gate Threshold Voltage	$V_{GS(th)}$	-0.4	-	-1.1	V	$V_{DS} = V_{GS}, I_D = 250 \mu\text{A}$
Gate Leakage Current	I_{GSS}	-	-	± 100	nA	$V_{GS} = \pm 8 \text{ V}$
Drain-Source Leakage Current ($T_j = 25^\circ\text{C}$)	I_{DSS}	-	-	-1	uA	$V_{DS} = -20 \text{ V}, V_{GS} = 0$
Drain-Source Leakage Current ($T_j = 70^\circ\text{C}$)		-	-	-20		$V_{DS} = -16 \text{ V}, V_{GS} = 0$
Drain-Source On-Resistance	$R_{DS(ON)}$	-	100	150	mΩ	$V_{GS} = -4.5 \text{ V}, I_D = -1.9 \text{ A}$
		-	160	210		$V_{GS} = -2.5 \text{ V}, I_D = -1.6 \text{ A}$
		-	260	300		$V_{GS} = -1.8 \text{ V}, I_D = -0.7 \text{ A}$
Forward Transconductance	g_{fs}	-	4	-	S	$V_{DS} = -5 \text{ V}, I_D = -1.9 \text{ A}$
Diode Forward Voltage ²	V_{SD}	-	-0.84	-1.1	V	$I_S = -1.0 \text{ A}, V_{GS} = 0 \text{ V}$
Dynamic						
Total Gate Charge ²	Q_g	-	6	7.5	nC	$I_D = -1.9 \text{ A}$ $V_{DS} = -10 \text{ V}$ $V_{GS} = -4.5 \text{ V}$
Gate-Source Charge	Q_{gs}	-	0.52	-		
Gate-Drain ("Miller") Charge	Q_{gd}	-	1.02	-		
Turn-on Delay Time ²	$T_{d(on)}$	-	50	65	nS	$V_{DS} = -10 \text{ V}$ $I_D = -1 \text{ A}$ $V_{GEN} = -4.5 \text{ V}$ $R_G = 6 \Omega$ $R_L = 10 \Omega$
Rise Time	T_r	-	40	60		
Turn-off Time	$T_{d(off)}$	-	168	180		
Fall Time	T_f	-	64	75		
Input Capacitance	C_{iss}	-	450	-	pF	$V_{GS} = 0 \text{ V}$ $V_{DS} = -15 \text{ V}$ $f = 1.0 \text{ MHz}$
Output Capacitance	C_{oss}	-	60	-		
Reverse Transfer Capacitance	C_{rss}	-	47	-		

- Notes: 1. Pulse width limited by maximum junction temperature.
 2. Pulse width $\leq 300 \mu\text{s}$, duty cycle $\leq 2\%$.
 3. Surface mounted on 1 in² copper pad of FR4 board; 180 °C/W when mounted on minimum copper pad.

CHARACTERISTIC CURVES

