

**Low Phase Noise VCXO (20MHz to 52MHz)**

**FEATURES**

- Integrated voltage-controlled crystal oscillator circuitry (VCXO) (pull range 380ppm minimum).
- VCXO tuning range: 0V -  $V_{DD}$ .
- Uses inexpensive fundamental-mode parallel resonant crystals (from 20 to 52MHz).
- 2.5V or 3.3V supply voltage.
- Selectable High Drive (30mA) or Standard Drive (10mA) CMOS output.
- Available in 8-Pin SOIC or TSSOP.

**PIN CONFIGURATION**

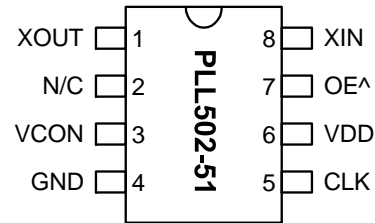

Note: ^ denotes internal pull up

**DESCRIPTION**

The PLL502-51 is a monolithic low jitter, high performance CMOS VCXO IC. It allows control of the output frequency with an input voltage (VCON), using a low cost crystal. This makes the PLL502-51 ideal for a wide range of applications from 20MHz to 52MHz (including 27MHz, 35.328MHz, etc.).

**OUTPUT RANGE**

MULTIPLIER	FREQUENCY RANGE	OUTPUT BUFFER
No PLL	20 - 52MHz	CMOS

**BLOCK DIAGRAM**

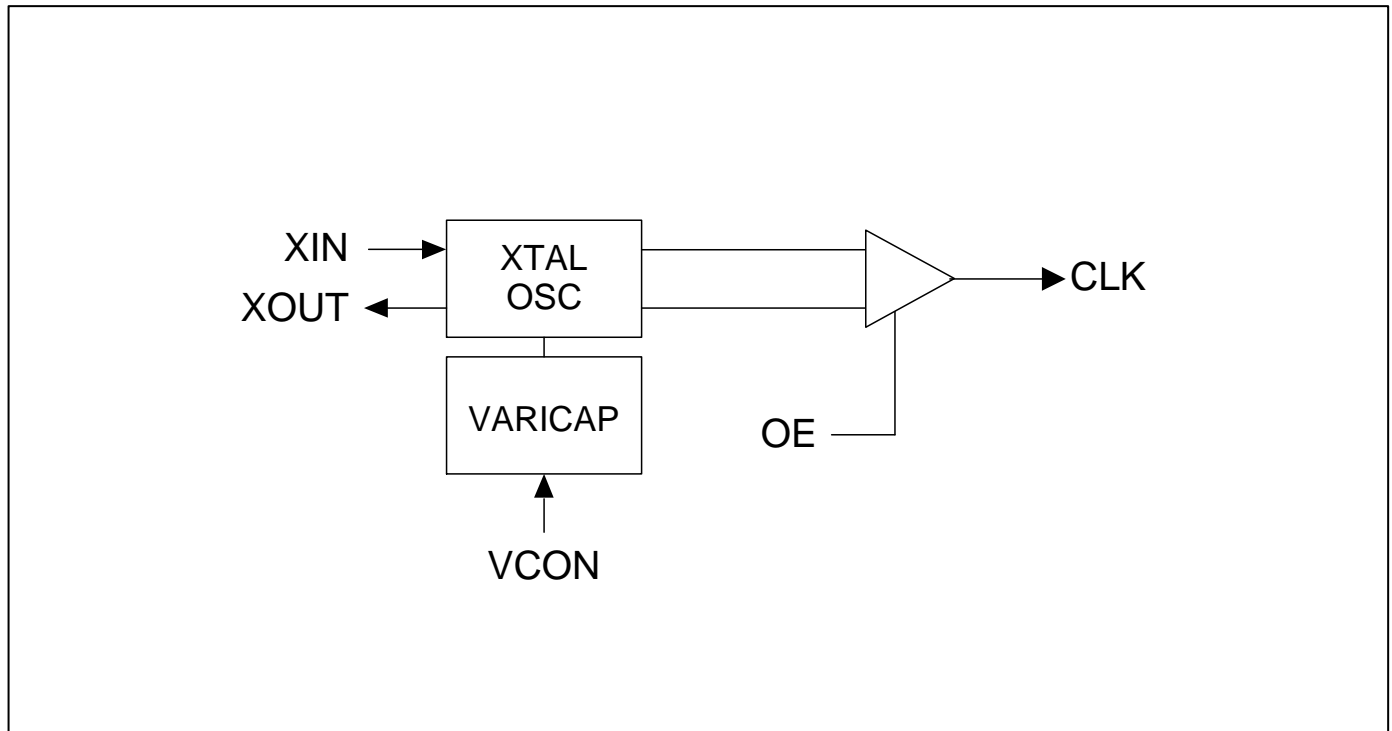

## Low Phase Noise VCXO (20MHz to 52MHz)

### PIN DESCRIPTIONS

Name	Number	Type	Description
XOUT	1	I	Crystal output. See Crystal Specification on page 4.
N/C	2	-	Not connected.
VCON	3	I	Voltage Control input.
GND	4	P	Ground.
CLK	5	O	Output clock.
VDD	6	P	Power supply.
OE	7	I	Output enable input. Disables (tri-state) output when low. Internal pull-up enables output by default if pin is not connected to low.
XIN	8	I	Crystal input. See Crystal Specification on page 4.

### ELECTRICAL SPECIFICATIONS

#### 1. Absolute Maximum Ratings

PARAMETERS	SYMBOL	MIN.	MAX.	UNITS
Supply Voltage	$V_{DD}$		4.6	V
Input Voltage, dc	$V_I$	-0.5	$V_{DD}+0.5$	V
Output Voltage, dc	$V_O$	-0.5	$V_{DD}+0.5$	V
Storage Temperature	$T_S$	-65	150	°C
Ambient Operating Temperature*	$T_A$	-40	85	°C
Junction Temperature	$T_J$		125	°C
Lead Temperature (soldering, 10s)			260	°C
ESD Protection, Human Body Model			2	kV

Exposure of the device under conditions beyond the limits specified by Maximum Ratings for extended periods may cause permanent damage to the device and affect product reliability. These conditions represent a stress rating only, and functional operations of the device at these or any other conditions above the operational limits noted in this specification is not implied.

\* **Note:** Operating Temperature is guaranteed by design for all parts (COMMERCIAL and INDUSTRIAL), but tested for COMMERCIAL grade only.

#### 2. DC Electrical Specifications

PARAMETERS	SYMBOL	CONDITIONS	MIN.	TYP.	MAX.	UNITS
Supply Current, Dynamic, with Loaded Outputs	$I_{DD}$	$F_{XIN} = 20 - 52\text{MHz}$ Output load of 10pF		10		mA
Operating Voltage	$V_{DD}$		2.25		3.63	V
Output drive current (High Drive)	$I_{OH}$	$V_{OH} = V_{DD}-0.4V, V_{DD}=3.3V$	30			mA
	$I_{OL}$	$V_{OL} = 0.4V, V_{DD} = 3.3V$	30			mA
Output drive current (Standard Drive)	$I_{OH}$	$V_{OH} = V_{DD}-0.4V, V_{DD}=3.3V$	10			mA
	$I_{OL}$	$V_{OL} = 0.4V, V_{DD} = 3.3V$	10			mA
Short Circuit Current				±50		mA
VCXO Control Voltage	VCON		0		$V_{DD}$	V

## Low Phase Noise VCXO (20MHz to 52MHz)

### 3. AC Electrical Specifications

PARAMETERS	SYMBOL	CONDITIONS	MIN.	TYP.	MAX.	UNITS
Input Crystal Frequency			20		52	MHz
Output Clock Rise/Fall Time (Standard Drive)		0.3V ~ 3.0V with 15 pF load		2.4		ns
Output Clock Rise/Fall Time (High Drive)		0.3V ~ 3.0V with 15 pF load		1.2		
Output Clock Duty Cycle		Measured @ 50% V <sub>DD</sub>	45	50	55	%

### 4. Voltage Control Crystal Oscillator (3.3V)

PARAMETERS	SYMBOL	CONDITIONS	MIN.	TYP.	MAX.	UNITS
VCXO Stabilization Time *	T <sub>VCXOSTB</sub>	From power valid			10	ms
VCXO Tuning Range		F <sub>XIN</sub> = 20 - 52MHz; XTAL C <sub>0</sub> /C <sub>1</sub> < 250 0V ≤ VCON ≤ 3.3V		500		ppm
CLK output pullability		VCON=1.65V ±1.65V	±200			ppm
VCXO Tuning Characteristic				150		ppm/V
Pull range linearity					10	%
VCON input impedance				80		kΩ
VCON modulation BW		0V ≤ VCON ≤ 3.3V, -3dB	10			kHz

Note: Parameters denoted with an asterisk (\*) represent nominal characterization data and are not production tested to any specific limits.

### 5. Jitter Specifications

PARAMETERS	CONDITIONS	MIN.	TYP.	MAX.	UNITS
Period jitter RMS	35.328 MHz		2.3		ps
Period jitter peak-to-peak	35.328MHz		18		ps
Integrated jitter RMS	Integrated 12 kHz to 20 MHz at 35.328MHz		1		ps

### 6. Phase Noise Specifications

PARAMETERS	FREQUENCY	@10Hz	@100Hz	@1kHz	@10kHz	@100kHz	UNITS
Phase Noise relative to carrier	51.85MHz	-65	-90	-120	-140	-147	dBc/Hz

Note: Phase Noise at VCON = 0V

**Low Phase Noise VCXO (20MHz to 52MHz)**

**7. Crystal Specifications**

PARAMETERS	SYMBOL	CONDITIONS	MIN.	TYP.	MAX.	UNITS
Crystal Resonator Frequency	$F_{XIN}$	Parallel Fundamental Mode	20		52	MHz
Crystal Loading Rating	$C_L (xtal)$	At $V_{con} = 1.65V$		9.5		pF
Crystal Pullability	$C_0/C_1 (xtal)$	AT cut			250	-
Recommended ESR	$R_E$	AT cut			30	$\Omega$

**Note:** Crystal Loading rating: 9.5pF is the loading the crystal sees from the VCXO chip at  $V_{CON} = 1.65V$ . It is assumed that the crystal will be at nominal frequency at this load. If the crystal requires more load to be at nominal frequency, the additional load must be added externally. This however may reduce the pull range

**PACKAGE INFORMATION**

8 PIN ( dimensions in mm )				
Symbol	Narrow SOIC		TSSOP	
	Min.	Max.	Min.	Max.
A	1.47	1.73	-	1.20
A1	0.10	0.25	0.05	0.15
B	0.33	0.51	0.19	0.30
C	0.19	0.25	0.09	0.20
D	4.80	4.95	2.90	3.10
E	3.80	4.00	4.30	4.50
H	5.80	6.20	6.20	6.60
L	0.38	1.27	0.45	0.75
e	1.27 BSC		0.65 BSC	

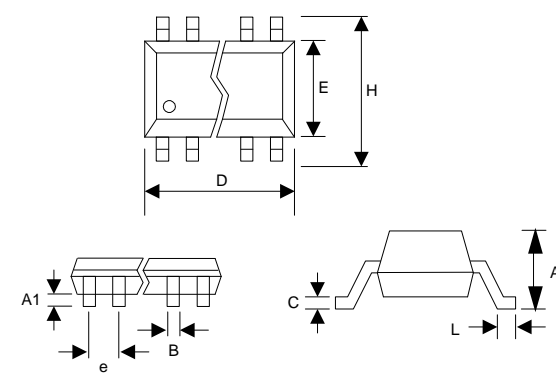

**Low Phase Noise VCXO (20MHz to 52MHz)**

**ORDERING INFORMATION**

**For part ordering, please contact our Sales Department:**

47745 Fremont Blvd., Fremont, CA 94538, USA

Tel: (510) 492-0990 Fax: (510) 492-0991

**PART NUMBER**

The order number for this device is a combination of the following:  
Device number, Package type and Operating temperature range

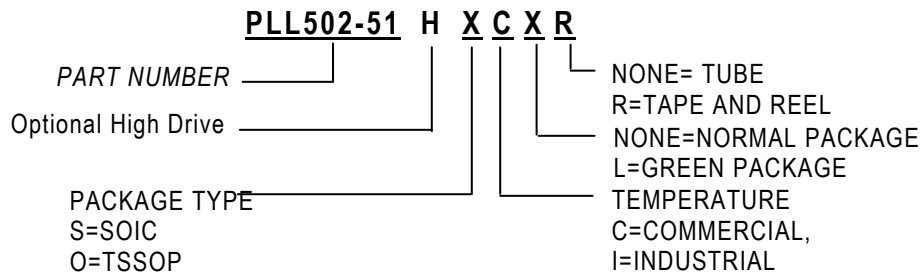

Order Number	Marking	Package Option
PLL502-51OC	P502-51OC	TSSOP – Tube
PLL502-51OC-R	P502-51OC	TSSOP - Tape and Reel
PLL502-51OCL	P502-51OCL	TSSOP – Tube, GREEN
PLL502-51OCL-R	P502-51OCL	TSSOP - Tape and Reel, GREEN
PLL502-51HOC	P502-51HOC	TSSOP – Tube
PLL502-51HOC-R	P502-51HOC	TSSOP - Tape and Reel
PLL502-51HOCL	P502-51HOCL	TSSOP – Tube, GREEN
PLL502-51HOCL-R	P502-51HOCL	TSSOP - Tape and Reel, GREEN
PLL502-51SC	P502-51SC	SOIC - Tube
PLL502-51SC-R	P502-51SC	SOIC - Tape and Reel
PLL502-51SCL	P502-51SCL	SOIC – Tube, GREEN
PLL502-51SCL-R	P502-51SCL	SOIC - Tape and Reel, GREEN
PLL502-51HSC	P502-51HSC	SOIC - Tube
PLL502-51HSC-R	P502-51HSC	SOIC - Tape and Reel
PLL502-51HSCL	P502-51HSCL	SOIC – Tube, GREEN
PLL502-51HSCL-R	P502-51HSCL	SOIC - Tape and Reel, GREEN

PhaseLink Corporation, reserves the right to make changes in its products or specifications, or both at any time without notice. The information furnished by Phaselink is believed to be accurate and reliable. However, PhaseLink makes no guarantee or warranty concerning the accuracy of said information and shall not be responsible for any loss or damage of whatever nature resulting from the use of, or reliance upon this product.

**LIFE SUPPORT POLICY:** PhaseLink's products are not authorized for use as critical components in life support devices or systems without the express written approval of the President of PhaseLink Corporation.