

CXM3531XR

Description

The CXM3531XR is a high power SP4T antenna switch for CDMA/UMTS applications. The antenna port can be routed to either of the 4TRx ports. The low insertion loss on transmit means increased talk time as the Tx power amplifier can be operated at a lower output level. Built-in decoder reduces component count and simplifies PCB layout by allowing direct connection of the switch to digital base band control lines with the 1.8V CMOS logic levels. The Sony GaAs JPHEMT MMIC Process is used for low insertion loss and high linearity. (Applications: CDMA/UMTS handsets)

Features

- ◆ Low insertion Loss (Tx): 0.28dB (Typ.) @27dBm (450MHz)
0.30dB (Typ.) @27dBm (Cellular)
0.36dB (Typ.) @27dBm (PCS)
0.38dB (Typ.) @27dBm (IMT2000)
0.45dB (Typ.) @27dBm (2.6GHz)
- ◆ High linearity: IIP3 = 70dBm
- ◆ No DC Blocking Capacitors required on RF ports.
- ◆ Lead-Free and RoHS Compliant

Package

Small package: 20pin XQFN (2.7mm × 2.7mm × 0.35mm Typ.)

Structure

GaAs JPHEMT MMIC

This IC is ESD sensitive device. Special handling precautions are required.

Sony reserves the right to change products and specifications without prior notice. This information does not convey any license by any implication or otherwise under any patents or other right. Application circuits shown, if any, are typical examples illustrating the operation of the devices. Sony cannot assume responsibility for any problems arising out of the use of these circuits.

 **Absolute Maximum Ratings**

◆ Bias voltage	V _{DD}	4V (Ta = 25°C)
◆ Control voltage	V _{ctl}	4V (Ta = 25°C)
◆ Input power Max. [Ant, RF1, RF2, RF3, RF4]		32dBm (410 to 2690MHz, Ta = 25°C)
◆ Operating temperature		-35 to +85°C
◆ Storage temperature		-65 to +150°C
◆ Maximum power dissipation	P _D	500mW *1

*1 25mm × 25mm × t:0.8mm Mounted on standard board (FR-4)

Block Diagram

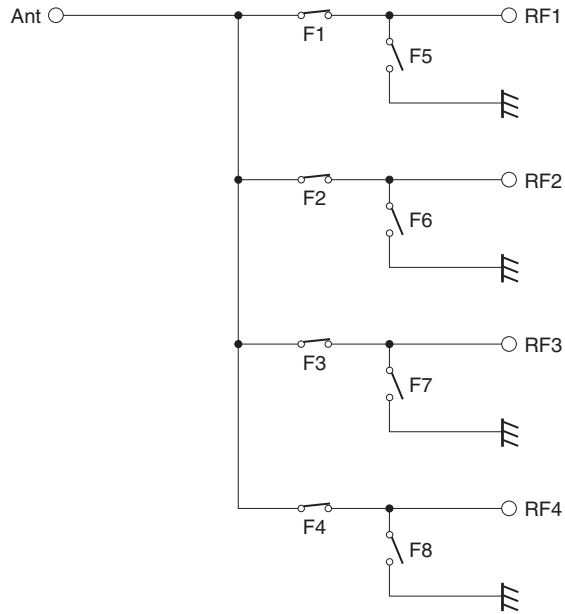

Pin Configuration

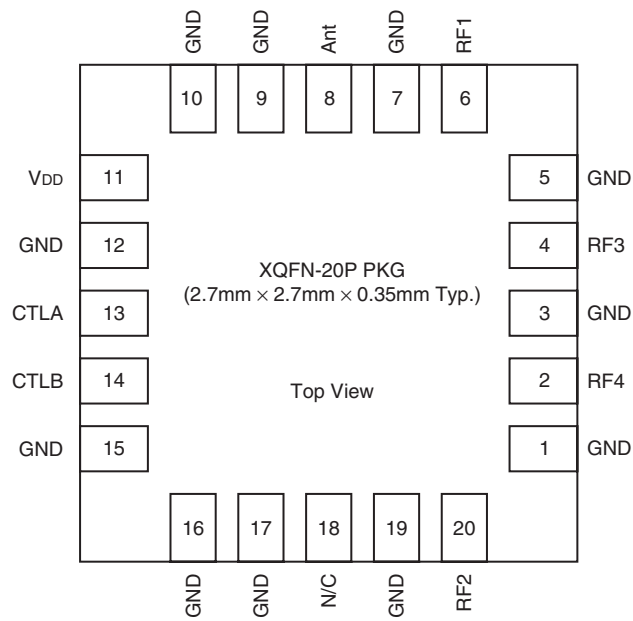

Truth Table

ON Path	CTLA	CTLB	F1	F2	F3	F4	F5	F6	F7	F8
ANT – RF1	L	L	ON	OFF	OFF	OFF	OFF	ON	ON	ON
ANT – RF2	H	L	OFF	ON	OFF	OFF	ON	OFF	ON	ON
ANT – RF3	L	H	OFF	OFF	ON	OFF	ON	ON	OFF	ON
ANT – RF4	H	H	OFF	OFF	OFF	ON	ON	ON	ON	OFF

DC Bias Condition

(Ta = 25°C)

Item	Min.	Typ.	Max.	Unit
Vctl (H)	1.3	1.8	3.2	V
Vctl (L)	0	—	0.3	
VDD	2.5	2.8	3.2	

Electrical Characteristics

Electrical Characteristics 1

(Ta = +25°C, V_{DD} = 2.8V, V_{ctl} = 0/1.8V)

Item	Symbol	Path	Condition	Min.	Typ.	Max.	Unit
Insertion Loss	IL	ANT-RF1	*1	—	0.28	0.43	dB
			*2	—	0.30	0.45	
			*3	—	0.36	0.51	
			*4	—	0.38	0.53	
			*5	—	0.45	0.60	
		ANT-RF2	*1	—	0.28	0.43	
			*2	—	0.30	0.45	
			*3	—	0.36	0.51	
			*4	—	0.38	0.53	
			*5	—	0.46	0.61	
		ANT-RF3	*1	—	0.25	0.40	
			*2	—	0.27	0.42	
			*3	—	0.33	0.48	
			*4	—	0.35	0.50	
			*5	—	0.42	0.57	
		ANT-RF4	*1	—	0.25	0.40	
			*2	—	0.27	0.42	
			*3	—	0.33	0.48	
			*4	—	0.35	0.50	
			*5	—	0.42	0.57	
Isolation	ISO.	ANT-RF1, 2, 3, 4	*1	30	41	—	dB
			*2	25	36	—	
			*3	22	27	—	
			*4	21	26	—	
			*5	18	23	—	

Electrical Characteristics are measured with all RF ports terminated in 50Ω.

- *1 freq = 410 to 495MHz
- *2 freq = 698 to 960MHz
- *3 freq = 1710 to 1990MHz
- *4 freq = 2110 to 2170MHz
- *5 freq = 2500 to 2690MHz

Electrical Characteristics 2

(Ta = +25°C, VDD = 2.8V, Vctl = 0/1.8V)

Item	Symbol	Path	Condition	Min.	Typ.	Max.	Unit
VSWR	VSWR		410 to 2170MHz	—	1.1	1.4	—
			2500 to 2690MHz	—	1.3	1.7	
Harmonics	2fo	ANT-RF1, 2, 3, 4	*1	—	-68	-40	dBm
	3fo			—	-68	-40	
	2fo		*2	—	-66	-40	
	3fo			—	-66	-40	
	2fo		*3	—	-66	-40	
	3fo			—	-63	-40	
	2fo		*4	—	-66	-40	
	3fo			—	-63	-40	
	2fo		*5	—	-62	-40	
	3fo			—	-59	-40	
P0.2dB compression input power	P0.2dB	ANT-RF1, 2, 3, 4	*1, *2, *3, *4, *5	31	—	—	dBm
Inter modulation product power in Rx band	IMD2	ANT-RF1, 2, 3, 4	*6-9, *17	—	-110	-105	dBm
	IMD3		*10-13, *17	—	-110	-105	
Input IP3	IIP3	ANT-RF1, 2, 3, 4	*14, *17	65	70	—	dBm
			*15, *17	65	70	—	
			*16, *17	65	70	—	
Control current	Ictl		Vctl = 1.8V	—	0.005	10	μA
Supply current	IDD		VDD = 2.8V	—	0.2	0.4	mA
Switching speed	Swt	RF1, 2, 3, 4	50% Ctl to 90% RF	—	2	5	μs

Electrical Characteristics are measured with all RF ports terminated in 50Ω.

- *1 Pin = 27dBm, freq = 410 to 484MHz
- *2 Pin = 27dBm, freq = 698 to 915MHz
- *3 Pin = 27dBm, freq = 1710 to 1910MHz
- *4 Pin = 27dBm, freq = 1920 to 1980MHz
- *5 Pin = 27dBm, freq = 2500 to 2570MHz
- *6 Pin on RF: 20dBm, 1950MHz, Pin on ANT: -15dBm, 190MHz
- *7 Pin on RF: 20dBm, 1745MHz, Pin on ANT: -15dBm, 95MHz
- *8 Pin on RF: 20dBm, 1880MHz, Pin on ANT: -15dBm, 80MHz
- *9 Pin on RF: 20dBm, 835MHz, Pin on ANT: -15dBm, 45MHz
- *10 Pin on RF: 20dBm, 1950MHz, Pin on ANT: -15dBm, 1760MHz
- *11 Pin on RF: 20dBm, 1745MHz, Pin on ANT: -15dBm, 1650MHz
- *12 Pin on RF: 20dBm, 1880MHz, Pin on ANT: -15dBm, 1800MHz
- *13 Pin on RF: 20dBm, 835MHz, Pin on ANT: -15dBm, 790MHz
- *14 Pin = 27 + 27dBm, 450 + 451MHz, IIP3 = (3 × Pout - IM3) / 2 + Loss
- *15 Pin = 27 + 27dBm, 835 + 836MHz, IIP3 = (3 × Pout - IM3) / 2 + Loss
- *16 Pin = 27 + 27dBm, 1950 + 1951MHz, IIP3 = (3 × Pout - IM3) / 2 + Loss
- *17 Measured with the recommended circuit

Electrical Characteristics 3

(Ta = +25°C, VDD = 2.8V, Vctl = 0/1.8V)

Item	Symbol	Path	Condition				Min.	Typ.	Max.	Unit	
Triple beat ratio	TBR		PTx at RF*			Jammer at Ant -30dBm [MHz]	Triple beat product at RF* [MHz]				
			Pin [dBm]	PTx1 [MHz]	PTx2 [MHz]						
		ANT-RF1, RF2, RF3, RF4	21.5	835.5	836.5	881.5	881.5 ± 1	81	—	—	dBc
			21.5	1880	1881	1960	1960 ± 1	81	—	—	
13.5	1732	1733	2132	2132 ± 1	81	—	—				

Electrical Characteristics are measured with all RF ports terminated in 50Ω.
Measured with the recommended circuit

Electrical Characteristics 4

(Ta = +25°C, VDD = 2.8V, Vctl = 0/1.8V)

Item	Symbol	Path	Condition			Min.	Typ.	Max.	Unit
Input IP2	IIP2	Ant-RF1, RF2, RF3, RF4	PTx at RF* 24dBm [MHz]	Jammer at ANT -20dBm [MHz]	IM2product at RF* [MHz]				dBm
			836.61	1718.61	881.61	113.5	—	—	
			836.61	45	881.61	95.5	—	—	
			1885	3850	1965	95.5	—	—	
			1885	80	1965	95.5	—	—	
			1732.5	3865	2132.5	95.5	—	—	
1732.5	400	2132.5	95.5	—	—				

Electrical Characteristics are measured with all RF ports terminated in 50Ω.
Measured with the recommended circuit

Recommended Circuit

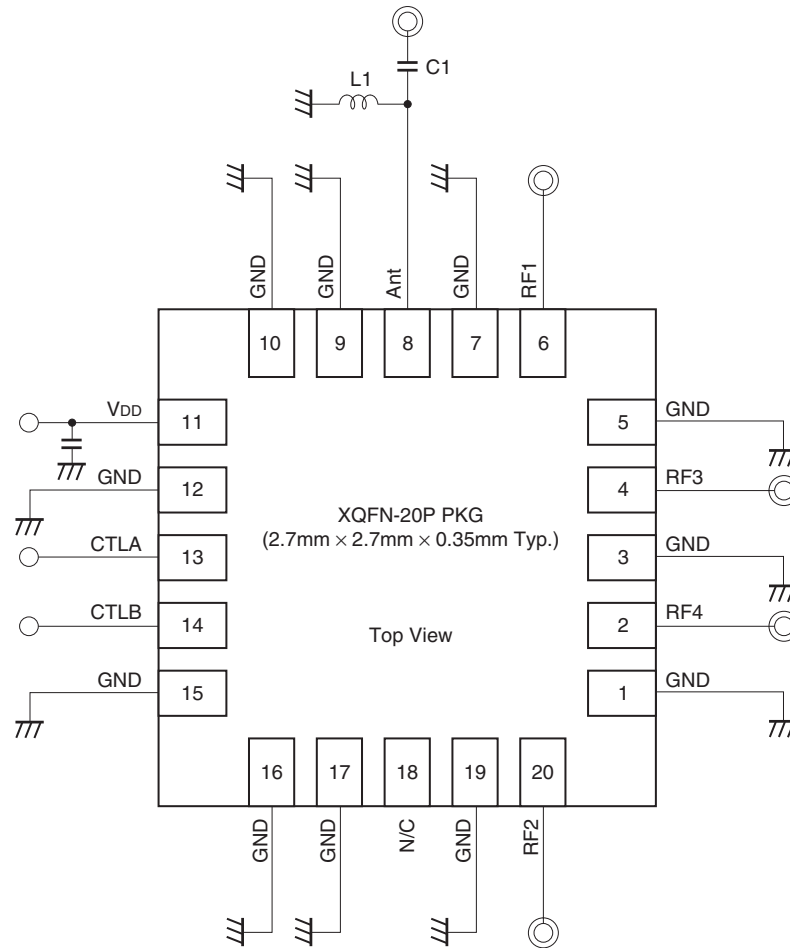

- Note) 1. No DC blocking capacitors are required on all RF ports.
 2. DC levels of all RF ports are GND.
 3. L1 (27nH) and C1 (12pF) are recommended on Ant port for ESD protection.

PCB Layout Template

XQFN-20P-01 Macro (Reference)

- ◆ PKG size: □ 2.7mm × t0.35mm
- ◆ Terminal pitch: 0.4mm
- ◆ Terminal length: 0.4mm
- ◆ Mask thickness: 0.11mm

- : Land area
- ▨ : Mask open area (Solder printing area)
- : Board resist open area
- ▩ : Metal area in board (*1)

*1 This metal is for heat loss reduction in package and recommend to connect to GND.

