

### Description

The CXM3544XR can be used in wireless communication systems, for example, dual-band/triple-band and antenna diversity CDMA handsets. This CXM3544XR has an integrated decoder 4 CMOS control inputs. The Sony JPHEMT process is used for low insertion loss and low distortion characteristic. (Applications: Antenna Switch for Cellular Handsets, Dual-band/Triple-band and Antenna Diversity)

### Features

- ◆ Low insertion loss: 0.30dB (Typ.) @900MHz, 0.4dB (Typ.) @2GHz
- ◆ High linearity: IIP3 = 63dBm (Min.)
- ◆ Low voltage operation:  $V_{DD} = 2.5V$
- ◆ No DC blocking capacitors
- ◆ 4 CMOS compatible control line
- ◆ Lead-Free and RoHS compliant

### Package

Small package XQFN 22pin (2.4mm × 3.3mm × 0.35mm) (Typ.)

### Structure

GaAs JPHEMT MMIC, CMOS Logic

### Absolute Maximum Ratings

◆ Bias voltage	$V_{DD}$	4	V (Ta = 25°C)
◆ Control voltage	$V_{ctl}$	4	V (Ta = 25°C)
◆ Operating temperature	$T_{opr}$	-35 to +90	°C
◆ Storage temperature	$T_{stg}$	-65 to +150	°C

This IC is ESD sensitive device. Special handling precautions are required.

Sony reserves the right to change products and specifications without prior notice. This information does not convey any license by any implication or otherwise under any patents or other right. Application circuits shown, if any, are typical examples illustrating the operation of the devices. Sony cannot assume responsibility for any problems arising out of the use of these circuits.

Block Diagram

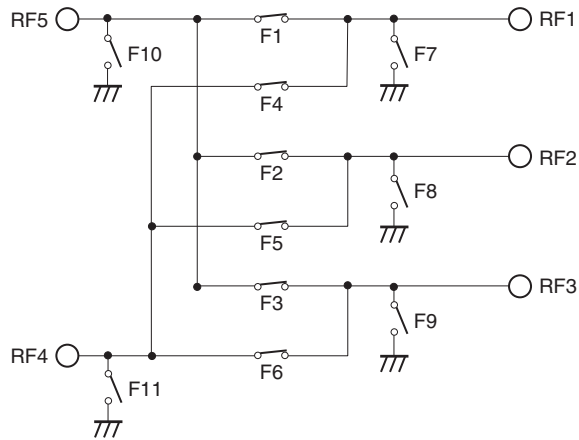

Pin Configuration

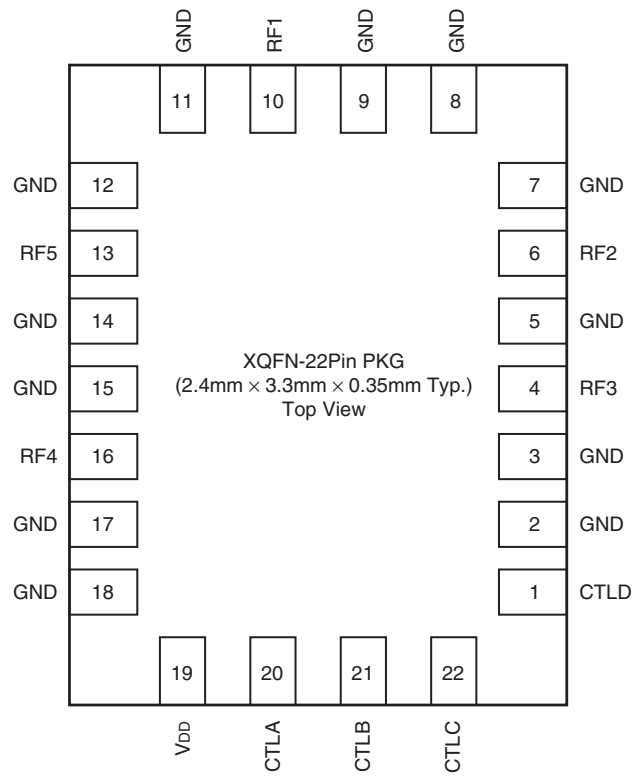

Truth Table

State	CTLA	CTLB	CTLC	CTLD	RF5 (Ant1)	RF4 (Ant2)	F1	F2	F3	F4	F5	F6	F7	F8	F9	F10	F11
1	H	L	L	L	RF1	OFF	ON	OFF	OFF	OFF	OFF	OFF	OFF	ON	ON	OFF	ON
2	L	H	L	L	RF2	OFF	OFF	ON	OFF	OFF	OFF	OFF	ON	OFF	ON	OFF	ON
3	L	L	L	L	RF3	OFF	OFF	OFF	ON	OFF	OFF	OFF	ON	ON	OFF	OFF	ON
4	H	L	H	L	OFF	RF1	OFF	OFF	OFF	ON	OFF	OFF	OFF	ON	ON	ON	OFF
5	L	H	H	L	OFF	RF2	OFF	OFF	OFF	OFF	ON	OFF	ON	OFF	ON	ON	OFF
6	L	L	H	L	OFF	RF3	OFF	OFF	OFF	OFF	OFF	ON	ON	ON	OFF	ON	OFF
7	H	H	L	H	RF1	RF2	ON	OFF	OFF	OFF	ON	OFF	OFF	OFF	ON	OFF	OFF
8	H	L	L	H	RF1	RF3	ON	OFF	OFF	OFF	OFF	ON	OFF	ON	OFF	OFF	OFF
9	H	H	H	H	RF2	RF1	OFF	ON	OFF	ON	OFF	OFF	OFF	OFF	ON	OFF	OFF
10	L	H	L	H	RF2	RF3	OFF	ON	OFF	OFF	OFF	ON	ON	OFF	OFF	OFF	OFF
11	H	L	H	H	RF3	RF1	OFF	OFF	ON	ON	OFF	OFF	OFF	ON	OFF	OFF	OFF
12	L	L	L	H	RF3	RF2	OFF	OFF	ON	OFF	ON	OFF	ON	OFF	OFF	OFF	OFF

DC Bias Condition

(Ta = -35 to +90°C)

Item	Min.	Typ.	Max.	Unit
Vctl (H)	1.3	1.8	3.2	V
Vctl (L)	0	—	0.3	
VDD	2.5	2.8	3.2	

**Electrical Characteristics 1**

(Ta = +25°C, VDD = 2.8V, Vctl = 0/1.8V)

Item	Symbol	Condition	Min.	Typ.	Max.	Unit
Control current	Ictl	Vctl = 1.8V, per 1 ctl pin	—	1	5	μA
Supply current	IDD	VDD = 2.8V	—	150	250	μA
Switching speed	Swt	VDD = 2.8V, Vctl = 0V/1.8V	—	—	5	μs

Electrical characteristics are measured with all RF ports terminated in 50Ω.

(Ta = +25°C, VDD = 2.8V, Vctl = 0/1.8V)

Item	Symbol	Path	Condition	Min.	Typ.	Max.	Unit
VSWR	VSWR	All port in active paths	824 to 2170MHz	—	1.1	1.4	—
P0.2dB Compression input power	P0.2dB	RF4 (Ant2) –RF1, 2, 3 RF5 (Ant1) –RF1, 2, 3	824 to 930MHz 1710 to 1980MHz	33	—	—	dBm
Input IP3	IIP3	RF4 (Ant2) –RF1, 2, 3 RF5 (Ant1) –RF1, 2, 3	*1, *3	65	—	—	dBm
			*2, *3	65	—	—	

Electrical characteristics are measured with all RF ports terminated in 50Ω.

\*1 Pin = 27 + 27dBm, 835 + 836MHz, IIP3 = (3 × Pout – IM3)/2 + Loss

\*2 Pin = 27 + 27dBm, 1950 + 1951MHz, IIP3 = (3 × Pout – IM3)/2 + Loss

\*3 Measured with recommended circuit

(Ta = +25°C, VDD = 2.8V, Vctl = 0/1.8V)

Item	Symbol	State *1	Path	Condition	Min.	Typ.	Max.	Unit
Insertion loss	IL	1-6	RF4 (Ant2) -RF1, 2, 3	Pin= 34dBm, 824 to 960MHz	—	0.30	0.45	dB
				Pin= 32dBm, 1710 to 1990MHz	—	0.35	0.50	
				Pin= 10dBm, 2110 to 2170MHz	—	0.40	0.55	
				Pin= 10dBm, 2500 to 2690MHz	—	0.45	0.60	
			RF5 (Ant1) -RF1, 2, 3	Pin= 34dBm, 824 to 960MHz	—	0.30	0.45	
				Pin= 32dBm, 1710 to 1990MHz	—	0.35	0.50	
				Pin= 10dBm, 2110 to 2170MHz	—	0.40	0.55	
				Pin= 10dBm, 2500 to 2690MHz	—	0.45	0.60	
		7-12	RF4 (Ant2) -RF1, 2, 3	Pin= 34dBm, 824 to 960MHz	—	0.33	0.48	dB
				Pin= 32dBm, 1710 to 1990MHz	—	0.45	0.60	
				Pin= 10dBm, 2110 to 2170MHz	—	0.50	0.65	
				Pin= 10dBm, 2500 to 2690MHz	—	0.60	0.75	
			RF5 (Ant1) -RF1, 2, 3	Pin= 34dBm, 824 to 960MHz	—	0.33	0.48	
				Pin= 32dBm, 1710 to 1990MHz	—	0.45	0.60	
				Pin= 10dBm, 2110 to 2170MHz	—	0.50	0.65	
				Pin= 10dBm, 2500 to 2690MHz	—	0.60	0.75	
Isolation	ISO	1-6	RF4 (Ant2) -RF1, 2, 3	Pin= 34dBm, 824 to 960MHz	25	35	—	dB
				Pin= 32dBm, 1710 to 1990MHz	20	28	—	
				Pin= 10dBm, 2110 to 2170MHz	20	27	—	
				Pin= 10dBm, 2500 to 2690MHz	20	25	—	
			RF5 (Ant1) -RF1, 2, 3	Pin= 34dBm, 824 to 960MHz	25	36	—	
				Pin= 32dBm, 1710 to 1990MHz	20	29	—	
				Pin= 10dBm, 2110 to 2170MHz	20	28	—	
				Pin= 10dBm, 2500 to 2690MHz	20	25	—	
		7-12	RF4 (Ant2) -RF1, 2, 3	Pin= 34dBm, 824 to 960MHz	21	—	—	dB
				Pin= 32dBm, 1710 to 1990MHz	16	—	—	
				Pin= 10dBm, 2110 to 2170MHz	15	—	—	
				Pin= 10dBm, 2500 to 2690MHz	13	—	—	
			RF5 (Ant1) -RF1, 2, 3	Pin= 34dBm, 824 to 960MHz	21	—	—	
				Pin= 32dBm, 1710 to 1990MHz	16	—	—	
				Pin= 10dBm, 2110 to 2170MHz	15	—	—	
				Pin= 10dBm, 2500 to 2690MHz	13	—	—	

Electrical characteristics are measured with all RF ports terminated in 50Ω.

\*1 Control state on truth table. (State 1-6: Single path mode, State 7-12: Simultaneous mode)

(Ta = +25°C, VDD = 2.8V, Vctl = 0/1.8V)

Item	Symbol	State *1	Path	Condition	Min.	Typ.	Max.	Unit
Harmonics	2f0	1-12	RF4 (Ant2) -RF1, 2, 3	Pin= 34dBm, 824 to 960MHz	—	-48	-36	dBm
	3f0				—	-44	-36	
	2f0			Pin= 32dBm, 1710 to 1990MHz	—	-46	-36	
	3f0				—	-47	-36	
	2f0			Pin= 26dBm, 1428 to 1453MHz	—	-65	-45	
	3f0				—	-65	-45	
	2f0		Pin= 26dBm, 1920 to 1980MHz	—	-61	-45		
	3f0			—	-64	-45		
	2f0		RF5 (Ant1) -RF1, 2, 3	Pin= 34dBm, 824 to 960MHz	—	-50	-36	dBm
	3f0				—	-44	-36	
	2f0			Pin= 32dBm, 1710 to 1990MHz	—	-52	-36	
	3f0				—	-46	-36	
	2f0	Pin= 26dBm, 1428 to 1453MHz		—	-65	-45		
	3f0			—	-65	-45		
2f0	Pin= 26dBm, 1920 to 1980MHz	—	-62	-45				
3f0		—	-65	-45				

Electrical characteristics are measured with all RF ports terminated in 50Ω.

\*1 Control state on truth table. (State 1-6: Single path mode, State 7-12: Simultaneous mode)

(Ta = +25°C, VDD = 2.8V, Vctl = 0/1.8V)

Item	Symbol	State *1	Path	Condition	Min.	Typ.	Max.	Unit
Intermodulation distortion	IMD2	1-12	RF4 (Ant2) -RF1, 2, 3	Ptx = 21.5dBm, Pjam = -15dBm, ftx = 835MHz, fjam = 45MHz, fim = 880MHz	—	-122	-105	dBm
				Ptx = 21.5dBm, Pjam = -15dBm, ftx = 835MHz, fjam = 1715MHz, fim = 880MHz	—	-118	-105	
				Ptx = 21.5dBm, Pjam = -15dBm, ftx = 1950MHz, fjam = 190MHz, fim = 2140MHz	—	-115	-105	
				Ptx = 21.5dBm, Pjam = -15dBm, ftx = 1950MHz, fjam = 4090MHz, fim = 2140MHz	—	-106	-102	
			RF5 (Ant1) -RF1, 2, 3	Ptx = 21.5dBm, Pjam = -15dBm, ftx = 835MHz, fjam = 45MHz, fim = 880MHz	—	-120	-105	
				Ptx = 21.5dBm, Pjam = -15dBm, ftx = 835MHz, fjam = 1715MHz, fim = 880MHz	—	-120	-105	
				Ptx = 21.5dBm, Pjam = -15dBm, ftx = 1950MHz, fjam = 190MHz, fim = 2140MHz	—	-107	-103	
				Ptx = 21.5dBm, Pjam = -15dBm, ftx = 1950MHz, fjam = 4090MHz, fim = 2140MHz	—	-112	-105	
	IMD3	1-12	RF4 (Ant2) -RF1, 2, 3	Ptx = 21.5dBm, Pjam = -15dBm, ftx = 835MHz, fjam = 790MHz, fim = 880MHz	—	-110	-105	dBm
				Ptx = 21.5dBm, Pjam = -15dBm, ftx = 835MHz, fjam = 2550MHz, fim = 880MHz	—	-113	-105	
				Ptx = 21.5dBm, Pjam = -15dBm, ftx = 1950MHz, fjam = 1760MHz, fim = 2140MHz	—	-108	-104	
				Ptx = 21.5dBm, Pjam = -15dBm, ftx = 1950MHz, fjam = 6040MHz, fim = 2140MHz	—	-111	-105	
			RF5 (Ant1) -RF1, 2, 3	Ptx = 21.5dBm, Pjam = -15dBm, ftx = 835MHz, fjam = 790MHz, fim = 880MHz	—	-110	-105	
				Ptx = 21.5dBm, Pjam = -15dBm, ftx = 835MHz, fjam = 2550MHz, fim = 880MHz	—	-113	-105	
				Ptx = 21.5dBm, Pjam = -15dBm, ftx = 1950MHz, fjam = 1760MHz, fim = 2140MHz	—	-108	-104	
				Ptx = 21.5dBm, Pjam = -15dBm, ftx = 1950MHz, fjam = 6040MHz, fim = 2140MHz	—	-111	-105	

Electrical characteristics are measured with all RF ports terminated in 50Ω.  
Measured with the recommended circuit.

\*1 Control state on truth table. (State 1-6: Single path mode, State 7-12: Simultaneous mode)

(Ta = +25°C, VDD = 2.8V, Vctl = 0/1.8V)

Item	Symbol	Path	Condition				Min.	Typ.	Max.	Unit	
			PTx at RF			Jammer at Ant -30dBm [dBm]					Triple beat product at RF [MHz]
			Pin [dBm]	PTx1 [MHz]	PTx2 [MHz]						
Triple beat ratio	TBR	RF4 (Ant2) -RF1, 2, 3	21.5	835.5	836.5	881.5	881.5 ± 1	81	—	dBc	
		RF5 (Ant1) -RF1, 2, 3	21.5	1880	1881	1960	1960 ± 1	81	—		
			13.5	1732	1733	2132	2132 ± 1	81	—		

Electrical characteristics are measured with all RF ports terminated in 50Ω.  
Measured with the recommended circuit.

(Ta = +25°C, VDD = 2.8V, Vctl = 0/1.8V)

Item	Symbol	Path	Condition			Min.	Typ.	Max.	Unit
			PTx at RF 24dBm [MHz]	Jammer at Ant -20dBm [MHz]	IM2 Product at RF [MHz]				
Input IP2	IIP2	RF4 (Ant2) -RF1, 2, 3 RF5 (Ant1) -RF1, 2, 3	836.61	1718.22	881.61	113.5	—	—	dBm
			836.61	45	881.61	95.5	—	—	
			1885	3850	1965	95.5	—	—	
			1885	80	1965	95.5	—	—	
			1732.5	3865	2132.5	95.5	—	—	
			1732.5	400	2132.5	95.5	—	—	

Electrical characteristics are measured with all RF ports terminated in 50Ω.  
Measured with the recommended circuit.



**Electrical Characteristics 2**

(Ta = -35 to +90°C , VDD = 2.5 to 3.2V, Vctl = 0/1.8V)

Item	Symbol	Condition	Min.	Typ.	Max.	Unit
Control current	Ictl	Vctl = 1.8V, per 1 ctl pin	—	—	5	μA
Supply current	IDD		—	—	350	μA
Switching speed	Swt	Vctl = 0V/1.8V	—	—	5	μs

Electrical characteristics are measured with all RF ports terminated in 50Ω.

(Ta = -35 to +90°C , VDD = 2.5 to 3.2V, Vctl = 0/1.8V)

Item	Symbol	Path	Condition	Min.	Typ.	Max.	Unit
VSWR	VSWR	All port in active paths	824 to 2170MHz	—	1.1	—	—
P0.2dB Compression input power	P0.2dB	RF4 (Ant2) -RF1, 2, 3 RF5 (Ant1) -RF1, 2, 3	824 to 930MHz 1710 to 1980MHz	33	—	—	dBm
Input IP3	IIP3	RF4 (Ant2) -RF1, 2, 3 RF5 (Ant1) -RF1, 2, 3	*1, *3	63	—	—	dBm
			*2, *3	63	—	—	

Electrical characteristics are measured with all RF ports terminated in 50Ω.

\*1 Pin = 27 + 27dBm, 835 + 836MHz, IIP3 = (3 × Pout - IM3)/2 + Loss

\*2 Pin = 27 + 27dBm, 1950 + 1951MHz, IIP3 = (3 × Pout - IM3)/2 + Loss

\*3 Measured with recommended circuit

(Ta = -35 to +90°C , VDD = 2.5 to 3.2V, Vctl = 0/1.8V)

Item	Symbol	State *1	Path	Condition	Min.	Typ.	Max.	Unit
Insertion loss	IL	1-6	RF4 (Ant2) -RF1, 2, 3	Pin= 34dBm, 824 to 960MHz	—	—	0.55	dB
				Pin= 32dBm, 1710 to 1990MHz	—	—	0.60	
				Pin= 10dBm, 2110 to 2170MHz	—	—	0.65	
				Pin= 10dBm, 2500 to 2690MHz	—	—	0.70	
			RF5 (Ant1) -RF1, 2, 3	Pin= 34dBm, 824 to 960MHz	—	—	0.55	
				Pin= 32dBm, 1710 to 1990MHz	—	—	0.60	
				Pin= 10dBm, 2110 to 2170MHz	—	—	0.65	
				Pin= 10dBm, 2500 to 2690MHz	—	—	0.70	
		7-12	RF4 (Ant2) -RF1, 2, 3	Pin= 34dBm, 824 to 960MHz	—	—	0.58	dB
				Pin= 32dBm, 1710 to 1990MHz	—	—	0.70	
				Pin= 10dBm, 2110 to 2170MHz	—	—	0.75	
				Pin= 10dBm, 2500 to 2690MHz	—	—	0.85	
			RF5 (Ant1) -RF1, 2, 3	Pin= 34dBm, 824 to 960MHz	—	—	0.58	
				Pin= 32dBm, 1710 to 1990MHz	—	—	0.70	
				Pin= 10dBm, 2110 to 2170MHz	—	—	0.75	
				Pin= 10dBm, 2500 to 2690MHz	—	—	0.85	
Isolation	ISO	1-6	RF4 (Ant2) -RF1, 2, 3	Pin= 34dBm, 824 to 960MHz	25	—	—	dB
				Pin= 32dBm, 1710 to 1990MHz	20	—	—	
				Pin= 10dBm, 2110 to 2170MHz	20	—	—	
				Pin= 10dBm, 2500 to 2690MHz	20	—	—	
			RF5 (Ant1) -RF1, 2, 3	Pin= 34dBm, 824 to 960MHz	25	—	—	
				Pin= 32dBm, 1710 to 1990MHz	20	—	—	
				Pin= 10dBm, 2110 to 2170MHz	20	—	—	
				Pin= 10dBm, 2500 to 2690MHz	20	—	—	
		7-12	RF4 (Ant2) -RF1, 2, 3	Pin= 34dBm, 824 to 960MHz	20	—	—	dB
				Pin= 32dBm, 1710 to 1990MHz	15	—	—	
				Pin= 10dBm, 2110 to 2170MHz	14	—	—	
				Pin= 10dBm, 2500 to 2690MHz	12	—	—	
			RF5 (Ant1) -RF1, 2, 3	Pin= 34dBm, 824 to 960MHz	20	—	—	
				Pin= 32dBm, 1710 to 1990MHz	15	—	—	
				Pin= 10dBm, 2110 to 2170MHz	14	—	—	
				Pin= 10dBm, 2500 to 2690MHz	12	—	—	

Electrical characteristics are measured with all RF ports terminated in 50Ω.

\*1 Control state on truth table. (State 1-6: Single path mode, State 7-12: Simultaneous mode)

(Ta = -35 to +90°C , VDD = 2.5 to 3.2V, Vctl = 0/1.8V)

Item	Symbol	State *1	Path	Condition	Min.	Typ.	Max.	Unit			
Harmonics	2f0	1-12	RF4 (Ant2) -RF1, 2, 3	Pin= 34dBm, 824 to 960MHz	—	—	-36	dBm			
	3f0				—	—	-36				
	2f0			Pin= 32dBm, 1710 to 1990MHz	—	—	-36				
	3f0				—	—	-36				
	2f0			Pin= 26dBm, 1428 to 1453MHz	—	—	-45				
	3f0				—	—	-45				
	2f0		Pin= 26dBm, 1920 to 1980MHz	—	—	-45					
	3f0			—	—	-45					
	Harmonics		2f0	1-12	RF5 (Ant1) -RF1, 2, 3	Pin= 34dBm, 824 to 960MHz	—		—	-36	dBm
			3f0				—		—	-36	
			2f0			Pin= 32dBm, 1710 to 1990MHz	—		—	-36	
			3f0				—		—	-36	
			2f0			Pin= 26dBm, 1428 to 1453MHz	—		—	-45	
			3f0				—		—	-45	
2f0		Pin= 26dBm, 1920 to 1980MHz	—			—	-45				
3f0			—			—	-45				

Electrical characteristics are measured with all RF ports terminated in 50Ω.

\*1 Control state on truth table. (State 1-6: Single path mode, State 7-12: Simultaneous mode)

(Ta = -35 to +90°C , VDD = 2.5 to 3.2V, Vctl = 0/1.8V)

Item	Symbol	State *1	Path	Condition	Min.	Typ.	Max.	Unit
Intermodulation distortion	IMD2	1-12	RF4 (Ant2) -RF1, 2, 3	Ptx = 21.5dBm, Pjam = -15dBm, ftx = 835MHz, fjam = 45MHz, fim = 880MHz	—	—	-102	dBm
				Ptx = 21.5dBm, Pjam = -15dBm, ftx = 835MHz, fjam = 1715MHz, fim = 880MHz	—	—	-102	
				Ptx = 21.5dBm, Pjam = -15dBm, ftx = 1950MHz, fjam = 190MHz, fim = 2140MHz	—	—	-102	
				Ptx = 21.5dBm, Pjam = -15dBm, ftx = 1950MHz, fjam = 4090MHz, fim = 2140MHz	—	—	-99	
			RF5 (Ant1) -RF1, 2, 3	Ptx = 21.5dBm, Pjam = -15dBm, ftx = 835MHz, fjam = 45MHz, fim = 880MHz	—	—	-102	
				Ptx = 21.5dBm, Pjam = -15dBm, ftx = 835MHz, fjam = 1715MHz, fim = 880MHz	—	—	-102	
				Ptx = 21.5dBm, Pjam = -15dBm, ftx = 1950MHz, fjam = 190MHz, fim = 2140MHz	—	—	-100	
				Ptx = 21.5dBm, Pjam = -15dBm, ftx = 1950MHz, fjam = 4090MHz, fim = 2140MHz	—	—	-102	
	IMD3	1-12	RF4 (Ant2) -RF1, 2, 3	Ptx = 21.5dBm, Pjam = -15dBm, ftx = 835MHz, fjam = 790MHz, fim = 880MHz	—	—	-102	dBm
				Ptx = 21.5dBm, Pjam = -15dBm, ftx = 835MHz, fjam = 2550MHz, fim = 880MHz	—	—	-102	
				Ptx = 21.5dBm, Pjam = -15dBm, ftx = 1950MHz, fjam = 1760MHz, fim = 2140MHz	—	—	-101	
				Ptx = 21.5dBm, Pjam = -15dBm, ftx = 1950MHz, fjam = 6040MHz, fim = 2140MHz	—	—	-102	
			RF5 (Ant1) -RF1, 2, 3	Ptx = 21.5dBm, Pjam = -15dBm, ftx = 835MHz, fjam = 790MHz, fim = 880MHz	—	—	-102	
				Ptx = 21.5dBm, Pjam = -15dBm, ftx = 835MHz, fjam = 2550MHz, fim = 880MHz	—	—	-102	
				Ptx = 21.5dBm, Pjam = -15dBm, ftx = 1950MHz, fjam = 1760MHz, fim = 2140MHz	—	—	-101	
				Ptx = 21.5dBm, Pjam = -15dBm, ftx = 1950MHz, fjam = 6040MHz, fim = 2140MHz	—	—	-102	

Electrical characteristics are measured with all RF ports terminated in 50Ω.  
Measured with the recommended circuit.

\*1 Control state on truth table. (State 1-6: Single path mode, State 7-12: Simultaneous mode)

Recommended Circuit

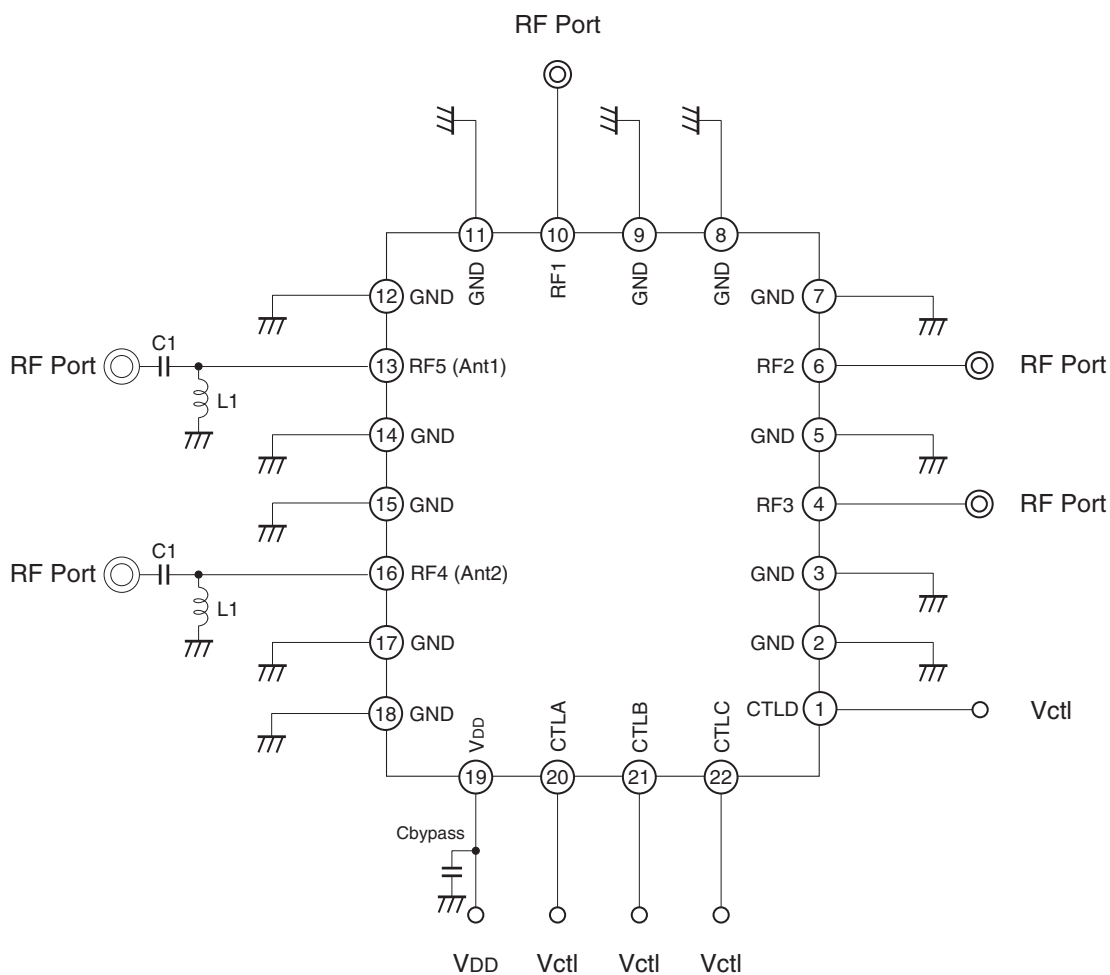

- Note) 1. No DC blocking capacitors are required on all RF ports.  
 2. The DC levels of all RF ports are GND.  
 3. L1 (27nH) and C1 (12pF) are recommended on antenna port for ESD protection.  
 4. Cbypass (100pF) is recommended on VDD for DC line filtering.

PCB Layout Template

**XQFN-22P-01 Macro for MMIC (Reference)**

**Specification**

- PKG size: 3.3mm × 2.4mm t0.35mm
- Terminal pitch: 0.4mm
- Terminal length: 0.3mm
- Mask thickness: 0.11mm

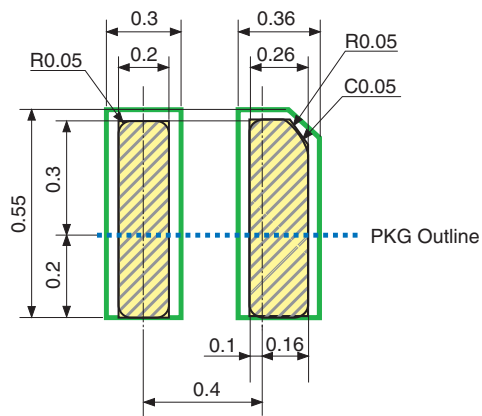
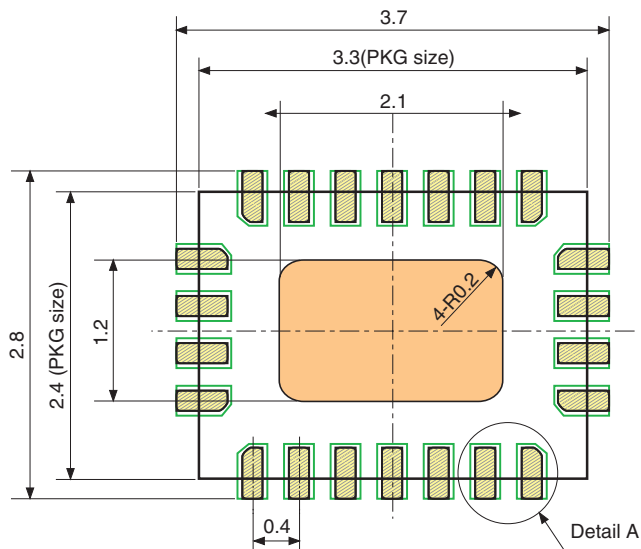

**Detail A**

- : Land area
- : Mask open area (Solder printing area)
- : Board resist open area
- : Metal area in board (GND plane is recommended.)
- : PKG outline

