



LC89170M

CD Player Text Data IC

Preliminary

Overview

The LC89170M is an IC that decodes the text data, such as song names, stored in subcode channels R to W of a compact disk's read-in area.

Features

- Accepts the channel R to W subcode data through a subcode interface.
- Can continuously output the channel R to W data for each 1PACK24 symbol.
- Performs error detection (cyclic redundancy code) and outputs both the data and the result of that check.
- Provides synchronization protection for the subcode interface.
- Supports low-voltage operation (3.3 V)
- Provided in the miniature MFP-14S package.

Package Dimensions

unit: mm

3111-MFP14S

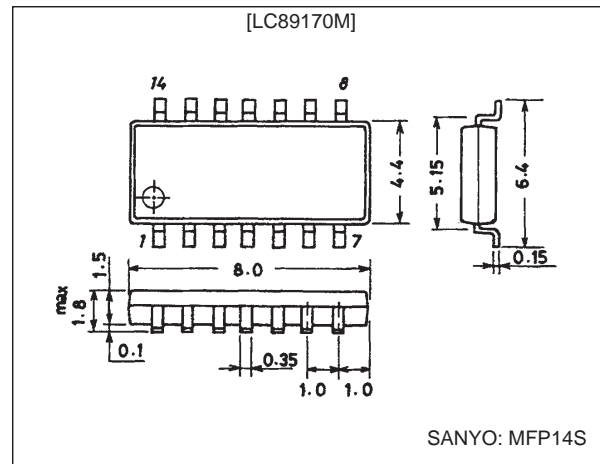

Specifications

Absolute Maximum Ratings at $T_a = 25\text{ }^\circ\text{C}$, $V_{SS} = 0\text{ V}$

Parameter	Symbol	Conditions	Ratings	Unit
Maximum supply voltage	$V_{DD\text{ max}}$		-0.3 to +7.0	V
I/O voltages	V_I, V_O		-0.3 to $V_{DD} + 0.3$	V
Input current	I_I		± 10	mA
Operating temperature	T_{opr}		-30 to +70	$^\circ\text{C}$
Storage temperature	T_{stg}		-55 to +125	$^\circ\text{C}$

Recommended Operating Conditions at $T_a = 25\text{ }^\circ\text{C}$, $V_{SS} = 0\text{ V}$

Parameter	Symbol	Conditions	Ratings			Unit
			min	typ	max	
Supply voltage	V_{DD}		3.0	5.0	5.5	V
Operating temperature	T_{opr}		-30		+70	$^\circ\text{C}$

SANYO Electric Co., Ltd. Semiconductor Business Headquarters

TOKYO OFFICE Tokyo Bldg., 1-10, 1 Chome, Ueno, Taito-ku, TOKYO, 110 JAPAN

93096HA (OT) No. 5536-1/8

LC89170M

Block Diagram

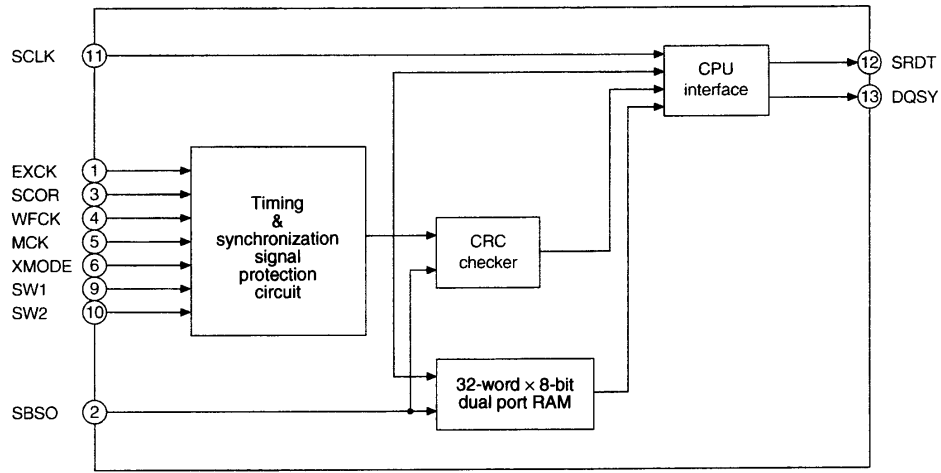

A06253

Pin Assignment

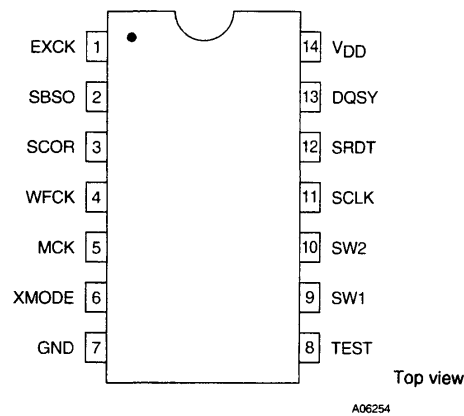

A06254

Pin Functions

Pin no.	Symbol	I/O	Function
1	EXCK	I/O	Subcode interface shift clock input and output
2	SBSO	I	Subcode interface data input
3	SCOR	I	Subcode interface block synchronization input
4	WFCCK	I	Subcode interface frame synchronization input
5	MCK	I	Clock input (16.9344 MHz)
6	XMODE	I	System reset and low power mode
7	GND		Ground
8	TEST	I	Test pin (Must be connected to ground in normal operation.)
9	SW1	I	EXCK I/O setting (L: clock output, H: clock input)
10	SW2	I	EXCK clock output pulse width selection (L: double speed support, H: normal speed)
11	SCLK	I	Command interface shift clock input
12	SRDT	O	Command interface data output
13	DQSY	O	Command interface readout enable output
14	V _{DD}		Power supply

LC89170M

DC Characteristics

DC Characteristics (1) at $T_a = -30$ to $+70^\circ\text{C}$, $V_{DD} = 4.5$ to 5.5 V, $V_{SS} = 0$ V

Parameter	Symbol	Conditions	Ratings			Unit
			min	typ	max	
Input high-level voltage	V_{IH}	CMOS compatible; 1*	$0.7 V_{DD}$			V
		CMOS compatible Schmitt; 2*	$0.8 V_{DD}$			V
Input low-level voltage	V_{IL}	CMOS compatible; 1*			$0.3 V_{DD}$	V
		CMOS compatible Schmitt; 2*			$0.2 V_{DD}$	V
Output high-level voltage	V_{OH}	$I_{OH} = -2$ mA; 3*	$V_{DD}-2.1$			V
Output low-level voltage	V_{OL}	$I_{OH} = 2$ mA; 3*			0.4	V
Current drain	I_{DD}	$V_{DD} = 5$ V, $T_a = 25^\circ\text{C}$, MCK = 16.93 MHz		0.8	1.6	mA
		$V_{DD} = 5$ V, XMODE = [L]		60	120	μA

Note: 1. The MCK, TEST, SW1, and SW2 pins
 2. The EXCK, SBSO, SCOR, WFCK, XMODE, and SCLK pins
 3. The EXCK, SRDT, and DQSY pins

DC Characteristics (2) at $T_a = -30$ to $+70^\circ\text{C}$, $V_{DD} = 3.0$ to 3.6 V, $V_{SS} = 0$ V

Parameter	Symbol	Conditions	Ratings			Unit
			min	typ	max	
Input high-level voltage	V_{IH}	CMOS compatible; 1*	$0.7 V_{DD}$			V
		CMOS compatible Schmitt; 2*	$0.75 V_{DD}$			V
Input low-level voltage	V_{IL}	CMOS compatible; 1*			$0.2 V_{DD}$	V
		CMOS compatible Schmitt; 2*			$0.15 V_{DD}$	V
Output high-level voltage	V_{OH}	$I_{OH} = -1$ mA; 3*	$V_{DD}-0.8$			V
Output low-level voltage	V_{OL}	$I_{OH} = 1$ mA; 3*			0.4	V
Current drain	I_{DD}	$V_{DD} = 3.3$ V, $T_a = 25^\circ\text{C}$, MCK = 16.93 MHz		0.5	1.0	mA
		$V_{DD} = 3.3$ V, XMODE = [L]		25	50	μA

Note: 1. The MCK, TEST, SW1, and SW2 pins
 2. The EXCK, SBSO, SCOR, WFCK, XMODE, and SCLK pins
 3. The EXCK, SRDT, and DQSY pins

AC Characteristics

- The MCK pin

AC Characteristics (1) at $T_a = -30$ to $+70^\circ\text{C}$, $V_{DD} = 3.0$ to 5.5 V, $V_{SS} = 0$ V

Parameter	Symbol	Conditions	Ratings			Unit
			min	typ	max	
High-level pulse width	t_{WH}		25		56	ns
Low-level pulse width	t_{WL}		25		56	ns
Pulse period	t_C		58		100	ns
Rise and fall times	t_R, t_F				12	ns

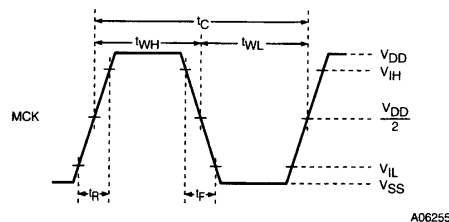

LC89170M

- The SCOR and WFCK pins

AC Characteristics (2) at Ta = -30 to +70°C, VDD = 3.0 to 5.5 V

Parameter	Symbol	Conditions	Ratings			Unit
			min	typ	max	
Subcode block period	T_B		6.0	13.3	14.7	ms
Subcode frame period	T_F		60	136	150	μ s
Subcode block synchronization pulse width	T_{BW}		60		300	μ s
Subcode frame synchronization pulse width	High-level pulse width	t_{HW}	4.0	68		μ s
	Low-level pulse width	t_{LW}	1.5	68		μ s

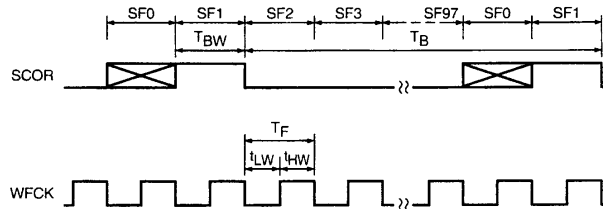

Note: The sections indicated by \boxtimes can be either level.

A06256

- The EXCK and SBSO pins

AC Characteristics (3) at Ta = -30 to +70°C, VDD = 3.0 to 5.5 V

Parameter	Symbol	Conditions	Ratings			Unit
			min	typ	max	
Synchronization clock pulse width	High-level pulse width	t_{HPW} [SW1] = [L]	0.9		6.4	μ s
		t_{HPW} [SW1] = [H]	2	4	6	μ s
	Low-level pulse width	t_{LPW} [SW1] = [L]	0.9		6.4	μ s
		t_{LPW} [SW1] = [H]	2	4	6	μ s
Shift clock delay time	t_{CD} [SW1] = [L]		10		32	μ s
	t_{CD} [SW1] = [H]		0.4			μ s
Shift clock rise and fall times	t_{RX}, t_{FX}				30	μ s
P data access time	t_{PAC}			3	10	μ s
Data hold time	t_{HD}		0			μ s

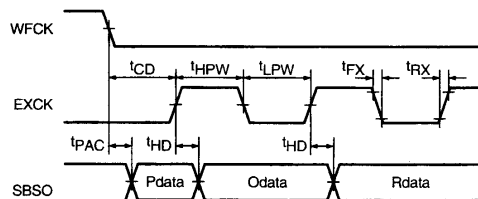

A06257

- The SCLK, SRDT, and DQSY pins

AC Characteristics (4) at Ta = -30 to +70°C, VDD = 3.0 to 5.5 V

Parameter	Symbol	Conditions	Ratings			Unit
			min	typ	max	
Readout period	t_{CW}		1.5	3.3	3.7	ms
DQSY pulse width	t_W		60	136	150	μ s
SCLK low-level pulse width	t_{WL}		100			ns
SCLK high-level pulse width	t_{WH}		100			ns
SCLK delay time	t_{D1}		100			ns
Data delay time	t_{D2}				50	ns
Data delay time	t_{D3}				50	ns

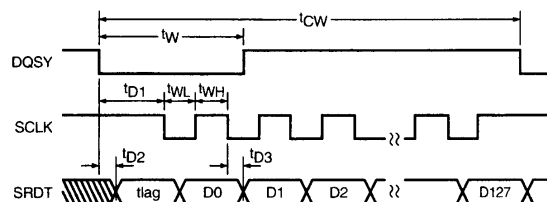

A06258

Functional Description

• Subcode interface

The LC89170M accepts subcode data from the DSP using the EXCK, SBSO, SCOR, and WFCK pins. Figure 1 shows the timing.

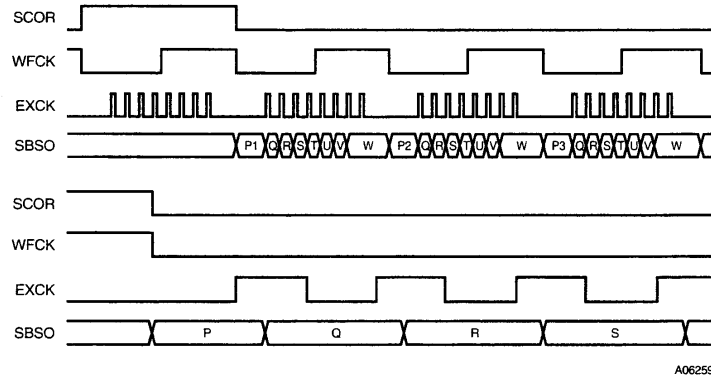

Figure 1 Subcode Interface Timing

SW1 sets the input or output state for the EXCK pin. This pin is provided for cases where a subcode interface shift clock source, such as a CD-G decoder circuit, is present in the vicinity of the LC89170M. Figure 2 shows usage examples.

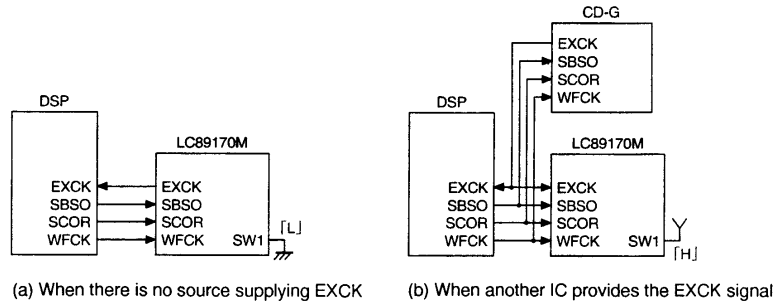

Figure 2 SW1 Usage Examples

The SW2 is selected according to the subcode block period, T_B , input to the SCOR pin.

SW2 Selection

SW2	Function	T_B	Unit
[L]	Supports up to double speed playback	6.65	ms
[H]	Only supports normal-speed playback	13.3	ms

The EXCK clock characteristics are determined by SW2 as listed in the table below.

EXCK Clock Selection by SW2

SW1	SW2	t_{CD}	t_{WH}	t_{WL}	Unit
[L]	[L]	12.28	1.89	1.89	μs
		$208T_{MCK}$	$32T_{MCK}$	$32T_{MCK}$	μs
[L]	[H]	18.90	7.56	7.56	μs
		$320T_{MCK}$	$128T_{MCK}$	$128T_{MCK}$	μs

The upper boxes assume MCK = 16.934 MHz
 The lower boxes indicate the relationship with MCK ($T_{MCK} = 1/MCK$)

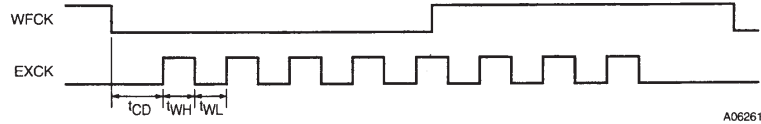

• Microcontroller interface

The LC89170M includes a 32-word \times 8-bit dual-port RAM on chip, and the 1PACK 24 symbols from subcode channels R to W can be read out once every 3.3 ms (or once every 1.66 for double-speed playback) over the microcontroller interface. Figure 3 shows the timing.

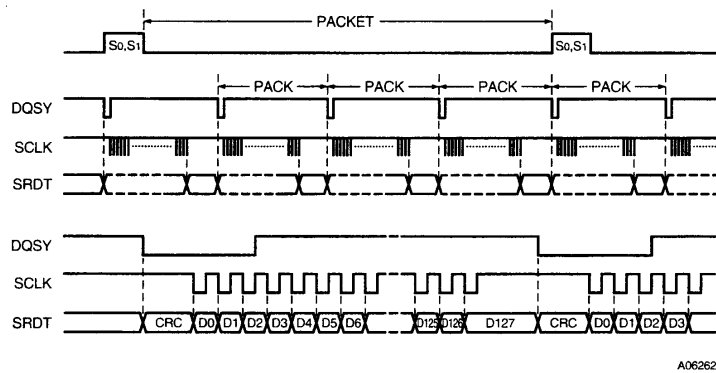

Figure 3 Microcontroller Interface Output Timing

The 1PACK 24 symbols for the subcode R to W data (18 bytes) are entered into the dual-port RAM and input to the CRC checking circuit. After the data for 1 PACK has all been input, a falling edge is output from the DQSY pin and the CRC flags are output from SRDT. A high is output for the CRC flags if the check returned OK. Next, 128 bits of data are output by inputting the SCLK clock signal. A single packet of data is output by repeating this operation four times.

• Synchronizing signal interpolation and protection

Although the LC89170M receives data from the DSP over the subcode interface, it is possible that due to reasons such as defects or damage to the disk, errors may occur in the synchronization pattern (SO, SI) making the LC89170M unable to detect that synchronization pattern, or a signal that is not a synchronizing signal (SCOR) may be recognized as a synchronizing signal making the LC89170M unable to correctly read out the data. The LC89170M includes a synchronizing signal interpolation and protection circuit to handle these problems. Figure 4 describes this interpolation and protection circuit.

Although the interpolation circuit generates a synchronizing signal for each packet, if the synchronizing signal is missing, it resets on the next detected synchronizing signal and once again generates a synchronizing signal for each packet. (1)

In the protection circuit, when a synchronizing signal is detected, if that synchronizing signal does not meet the stipulated period ($98 \times \text{WFCK}$) with respect to the previously detected synchronizing signal, the protection circuit has the LC89170M ignore that detected synchronizing signal. This prevents signals that are not synchronizing signals from being mistakenly recognized as synchronizing signals. (2)

The processing performed by these circuit is reflected in the CRC flags.

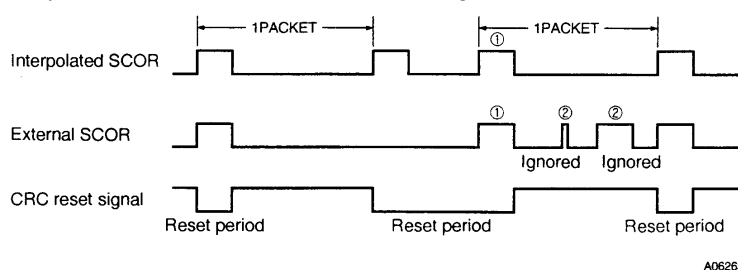

Figure 4 Synchronizing Signal Interpolation and Protection

At the point marked (1) in the figure, an external SCOR that differs from the interpolated was detected, and here the interpolation circuit is synchronized with this signal.

At the point marked (2) in the figure, an external SCOR that differs from the interpolated was detected, but this external SCOR will be ignored and the interpolation circuit will not be re-synchronized.

• System reset and low power mode

The XMODE pin functions to reset the system and to switch to low power mode. System operation can be started correctly by applying a high level to this pin after the power-supply voltage has risen above 4.5 V (or 3.0 V). Setting the XMODE pin low switches the LC89170M to low power mode.

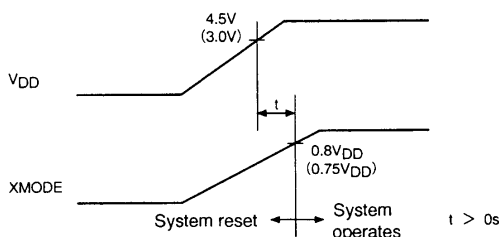

Application Circuit Example

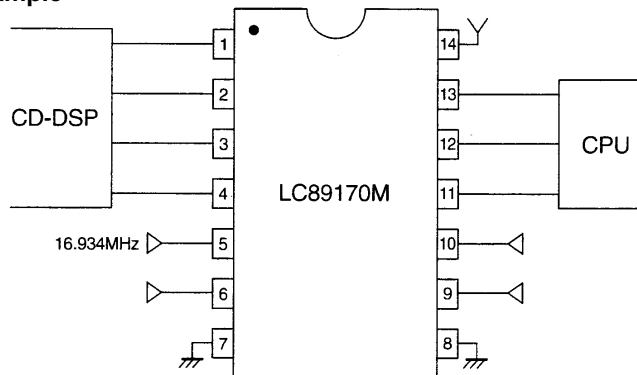

- No products described or contained herein are intended for use in surgical implants, life-support systems, aerospace equipment, nuclear power control systems, vehicles, disaster/crime-prevention equipment and the like, the failure of which may directly or indirectly cause injury, death or property loss.
- Anyone purchasing any products described or contained herein for an above-mentioned use shall:
 - ① Accept full responsibility and indemnify and defend SANYO ELECTRIC CO., LTD., its affiliates, subsidiaries and distributors and all their officers and employees, jointly and severally, against any and all claims and litigation and all damages, cost and expenses associated with such use:
 - ② Not impose any responsibility for any fault or negligence which may be cited in any such claim or litigation on SANYO ELECTRIC CO., LTD., its affiliates, subsidiaries and distributors or any of their officers and employees jointly or severally.
- Information (including circuit diagrams and circuit parameters) herein is for example only; it is not guaranteed for volume production. SANYO believes information herein is accurate and reliable, but no guarantees are made or implied regarding its use or any infringements of intellectual property rights or other rights of third parties.

This catalog provides information as of September, 1996. Specifications and information herein are subject to change without notice.