



LC89901V

CMOS Driver IC for 1/5 and 1/6 Inch Image Sensors

Overview

The LC89901V is a high breakdown voltage CMOS vertical driver IC for 1/5 and 1/6 inch image sensors. Provision of a built-in level shifter means that an external clamp circuit is no longer required.

Applications

Surveillance cameras and image input equipment

Functions

CMOS driver IC for 1/5 and 1/6 inch sensors

Features

- CMOS process fabrication for low power dissipation
- Built-in level shifter circuits to reduce the number of required peripheral circuits.
- Miniature package (SSOP-24)

Structure

- Inverter type drivers: 8 channels
Input pulses are converted to V_{CC1} , V_{CC2} and V_{EE1} , V_{EE2} levels (inversion).
These are drivers for image sensor imaging and storage sections.

- Inverter type driver: 1 channel
Input pulses are converted to V_{CCN} and V_{EE1} , V_{EE2} levels (inversion).
This circuit is an image sensor NSUB driver.

Package Dimensions

unit: mm

3175A-SSOP24

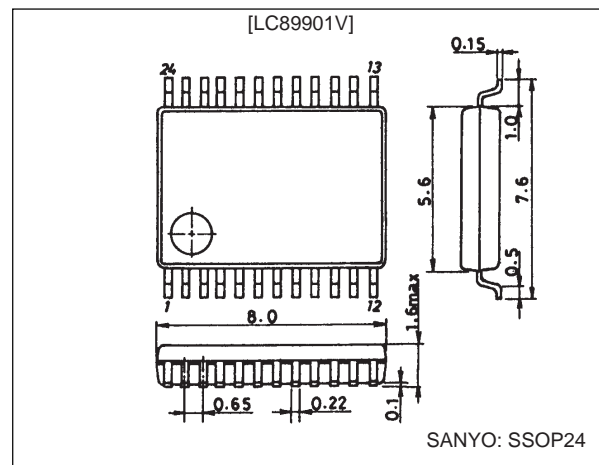

Specifications

Absolute Maximum Ratings at $T_a = 25^\circ\text{C}$

Parameter	Symbol	Conditions	Ratings	Unit
Maximum supply voltage	$V_{CC \text{ max}}$	$V_{CC1}, V_{CC2}, V_{CCN}$	-0.3 to +6.0	V
	$V_{EE \text{ max}}$	V_{EE1}, V_{EE2}	+0.3 to -11.0	V
Input voltage	V_{IN}	All input pins	-0.3 to $V_{CC} + 0.3$	V
Allowable power dissipation	$P_d \text{ max}$		350	mA
Operating temperature	T_{opr}		-10 to +70	$^\circ\text{C}$
Storage temperature	T_{stg}		-40 to +125	$^\circ\text{C}$

Allowable Operating Ranges at $T_a = 25^\circ\text{C}$

Parameter	Symbol	Conditions	Ratings	Unit
Supply voltage	V_{CC}	$V_{CC1}, V_{CC2}, V_{CCN}$: * $V_{CCN} \leq V_{CC1}, V_{CC2}$	4.5 to 5.5	V
	V_{EE}	V_{EE1}, V_{EE2}	0 to -10.5	V
Input voltage range	V_{IN}	All input pins	0 to V_{CC}	V

SANYO Electric Co.,Ltd. Semiconductor Business Headquarters

TOKYO OFFICE Tokyo Bldg., 1-10, 1 Chome, Ueno, Taito-ku, TOKYO, 110 JAPAN

73097HA (OT)/32895TH (OT) NO. 5078-1/4

LC89901V

Block Diagram

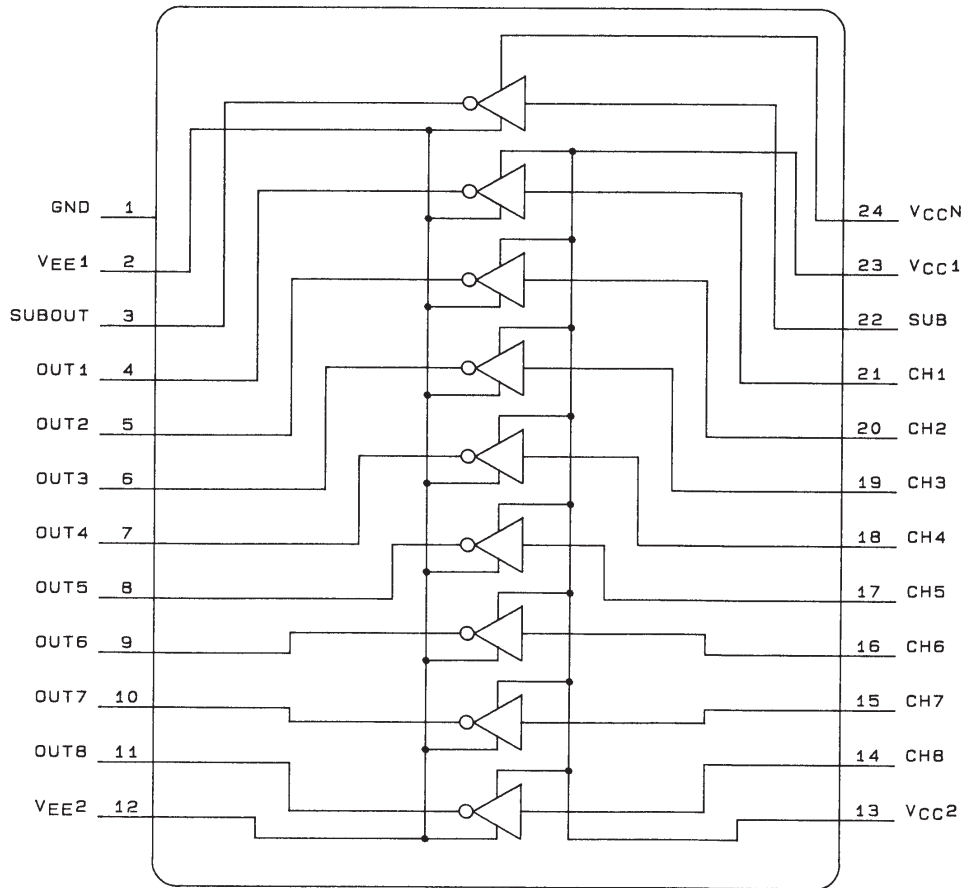

A03742

Electrical Characteristics at $T_a = 25^\circ\text{C}$, V_{CC1} , V_{CC2} , $V_{CCN} = 5.0\text{ V}$, V_{EE1} , $V_{EE2} = -10.0\text{ V}$

Parameter	Symbol	Conditions	min	typ	max	Unit
Input high level current	I_{IH}	All input pins, $V_{IN} = 5.0\text{ V}$		10		μA
Input low level current	I_{IL}	All input pins, $V_{IN} = 0\text{ V}$		5		nA
Current drain	I_{CCH+}	V_{CC1} , V_{CC2} , V_{CCN} , all input pins, $V_{IN} = 5.0\text{ V}$		1		μA
	I_{CCH-}	V_{EE1} , V_{EE2} , all input pins, $V_{IN} = 5.0\text{ V}$		-10		μA
	I_{CCL+}	V_{CC1} , V_{CC2} , V_{CCN} , all input pins, $V_{IN} = 0\text{ V}$		7		μA
	I_{CCH-}	V_{EE1} , V_{EE2} , all input pins, $V_{IN} = 0\text{ V}$		-2		μA
Output voltage	V_{OH}	All inputs, $V_{IN} = 0\text{ V}$		5.0		V
	V_{OL}	All inputs, $V_{IN} = 5.0\text{ V}$		-10.0		V
Operating output voltage*	V_{OH2}	Load = LC9997, input = LC99052		5.0		V
	V_{OL2}	Load = LC9997, input = LC99052		-10.0		V
Operating current drain*	I_{CC2+}	Load = LC9997, input = LC99052		1.62		mA
	I_{CC2-}	Load = LC9997, input = LC99052		1.61		mA

Note: Load conditions
Load circuit

$$R_L = 18\ \Omega, C_L = 780\ \text{pF}$$

* Reference values for driving an LC9997 image sensor with pulses input from an LC99052 timing LSI.

LC89901V

Switching Characteristics at $T_a = 25^\circ\text{C}$, $V_{CC1}, V_{CC2}, V_{CCN} = 5.0\text{ V}$, $V_{EE1}, V_{EE2} = -10.0\text{ V}$, $f_{IN} = 3.58\text{ MHz}$

Parameter	Symbol	Conditions	min	typ	max	Unit
Propagation delay Low level → high level t_{PLH}	t_{PLH}	All output pins		23		ns
Propagation delay High level → low level t_{PHL}	t_{PHL}	All output pins		31		ns
Rise time	t_r	All output pins		47		ns
Fall time	t_f	All output pins		42		ns

Switching Waveforms

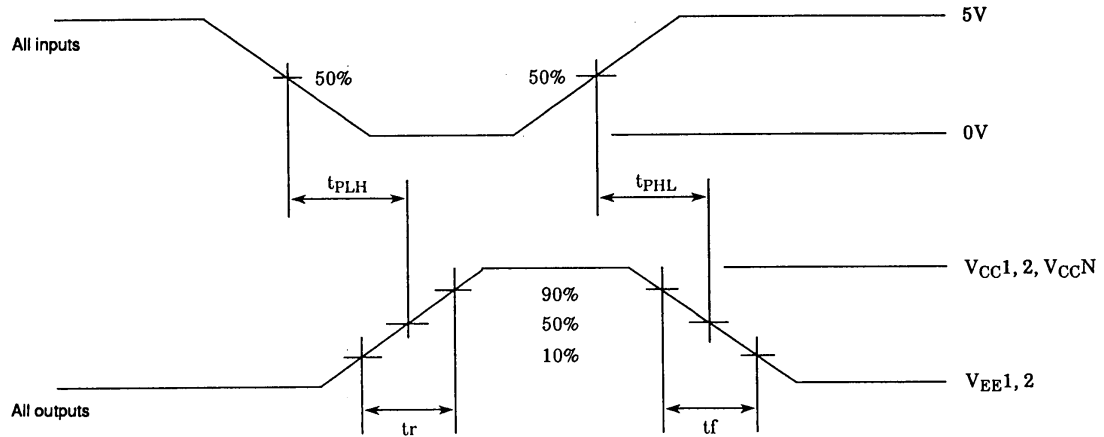

Truth table

		Output	
		H	L
Input	H	V_{OL}	V_{OH}
	L	V_{OH}	V_{OL}

Pin Functions

Pin No.	Pin	Function
1	GND	Ground
2	V_{EE1}	Negative power supply for setting the low level
3	SUBOUT	NSUB driver output
4	OUT1	Channel 1 driver output
5	OUT2	Channel 2 driver output
6	OUT3	Channel 3 driver output
7	OUT4	Channel 4 driver output
8	OUT5	Channel 5 driver output
9	OUT6	Channel 6 driver output
10	OUT7	Channel 7 driver output
11	OUT8	Channel 8 driver output
12	V_{EE2}	Negative power supply for setting the low level
13	V_{CC2}	Positive power supply for setting the high level
14	CH8	Channel 8 driver input
15	CH7	Channel 7 driver input
16	CH6	Channel 6 driver input
17	CH5	Channel 5 driver input
18	CH4	Channel 4 driver input
19	CH3	Channel 3 driver input
20	CH2	Channel 2 driver input
21	CH1	Channel 1 driver input
22	SUB	NSUB driver input
23	V_{CC1}	Positive power supply for setting the high level
24	V_{CCN}	NSUB driver positive power supply

Sample Application Circuit

This figure shows the block diagram of an image sensor based digital camera using the Sanyo LC99052-V64, LC99062-W50 and LC89901V.

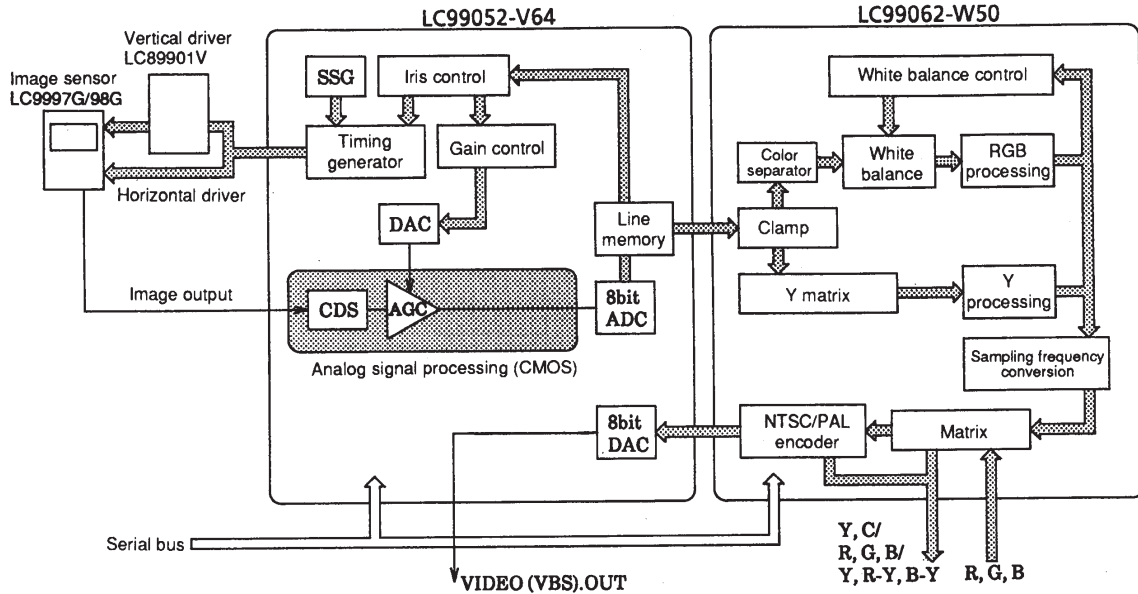

A03744

- No products described or contained herein are intended for use in surgical implants, life-support systems, aerospace equipment, nuclear power control systems, vehicles, disaster/crime-prevention equipment and the like, the failure of which may directly or indirectly cause injury, death or property loss.
- Anyone purchasing any products described or contained herein for an above-mentioned use shall:
 - ① Accept full responsibility and indemnify and defend SANYO ELECTRIC CO., LTD., its affiliates, subsidiaries and distributors and all their officers and employees, jointly and severally, against any and all claims and litigation and all damages, cost and expenses associated with such use:
 - ② Not impose any responsibility for any fault or negligence which may be cited in any such claim or litigation on SANYO ELECTRIC CO., LTD., its affiliates, subsidiaries and distributors or any of their officers and employees jointly or severally.
- Information (including circuit diagrams and circuit parameters) herein is for example only; it is not guaranteed for volume production. SANYO believes information herein is accurate and reliable, but no guarantees are made or implied regarding its use or any infringements of intellectual property rights or other rights of third parties.

This catalog provide information as of June, 1997. Specifications and information herein are subject to change without notice.