

Overview

The LC89915 and LC89915M are delay lines that produce a 1 H delayed signal for NTSC format with an external low-pass filter. It can also provide 1 H delayed signal for PAL format by changing the number of its CCD shift register.

Functions

- 453.5 bits (switchable to 456.5 bits) CCD shift register
- Auto-bias circuit
- Sync tip clamping circuit
- Sample-and-hold circuit
- Delay time switching circuit

Features

- Single 5 V power supply
- Operates on a low-amplitude clock input.
- Built-in peripheral circuits allow applications to be constructed with a minimum number of external components.
- Positive-phase signal input/positive-phase signal output
- Control pin switchable to provide a PAL 1 H delayed signal.

Package Dimensions

unit: mm

3001B-DIP8

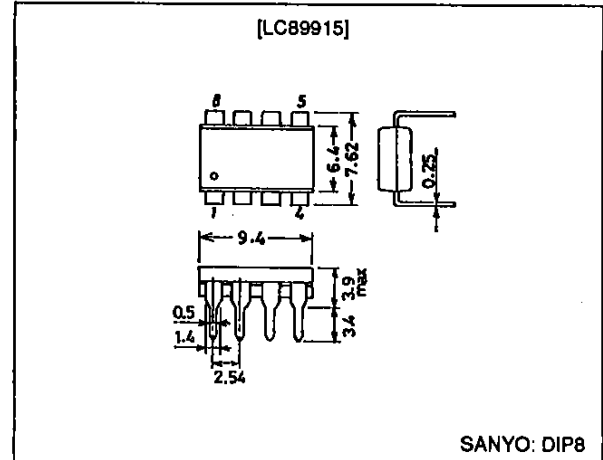

unit: mm

3032B-MFP8

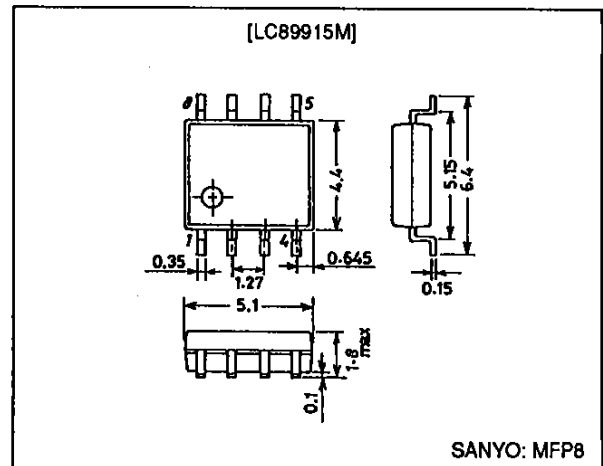

Specifications

Absolute Maximum Ratings at $T_a = 25^\circ\text{C}$

Parameter	Symbol	Conditions	Ratings	Unit
Maximum supply voltage	$V_{DD\ max}$		-0.3 to +6.0	V
Allowable power dissipation	$P_d\ max$	LC89915	400	mW
		LC89915M	140	mW
Operating temperature	T_{opr}		-10 to +60	$^\circ\text{C}$
Storage temperature	T_{stg}		-55 to +150	$^\circ\text{C}$

SANYO Electric Co., Ltd. Semiconductor Business Headquarters
TOKYO OFFICE Tokyo Bldg., 1-10, 1 Chome, Ueno, Taito-ku, TOKYO, 110 JAPAN

72595TH (OT) No. 5115-1/4

Allowable Operating Ranges at Ta = 25°C

Parameter	Symbol	Conditions	min	typ	max	Unit
Supply voltage	V _{DD}		4.75	5.00	5.25	V
Clock input amplitude	V _{CLK}	Sine wave	100	300	1000	mVp-p
Clock frequency	F _{CLK}		—	7.1590909	—	MHz
Signal input amplitude	V _{IN}	*	—	500	—	mVp-p

Note: * Connect the input signal with a low impedance to assure correct sync tip clamping.

Pin Assignment

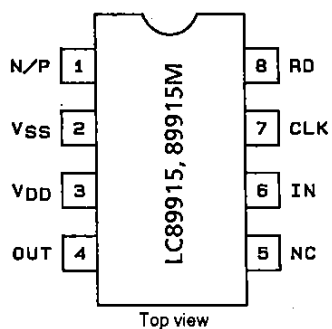

A03625

Pin Functions

Pin No.	Symbol	Function
1	N/P	Delay time switching
2	V _{SS}	GND
3	V _{DD}	Power supply
4	OUT	Delayed signal output
5	NC	
6	IN	Signal input
7	CLK	Clock input
8	RD	RD-voltage generator output

Block Diagram

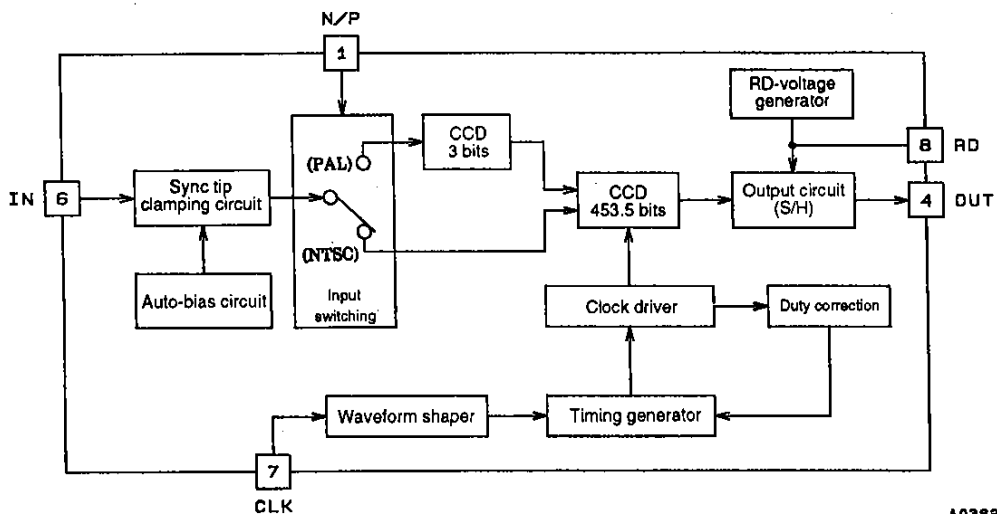

A03625

Functional Description

The delay time can be switched with the N/P control pin (pin 1).

0 V — NTSC mode

The CCD has a length of 453.5 bits and the delay time corresponds to 1 H (63.5 μs) in the NTSC format.

5 V — PAL mode

The CCD has a length of 456.5 bits and the delay time corresponds to 1 H (64.0 μs) in the PAL format.

LC89915, 89915M

Electrical Characteristics at Ta = 25°C, VDD = 5.0 V, CLK = 7.1590909 MHz; 300 mVp-p; sine wave

Parameter	Symbol	Conditions	min	typ	max	Unit
Current drain	I _{DD}	No signal input	4	8	12	mA
Voltage gain	G _V	With a 200 kHz 0.5 Vp-p input	2.5	4.5	6.5	dB
Frequency characteristics	G _f	2.0 MHz, 0.2 Vp-p/200 kHz, 0.2 Vp-p	-3.0	-1.5		dB
Linearity	L ₆	*	56	60	64	%
	L ₂	*	18	20	22	%
	L _S	*	37	40	43	%
Clock leakage	I _{CLK}	No signal input, the 2 fsc component		10	30	mVrms
Noise	N _O	No signal input, 4.2 MHz bandwidth		1.0	2.0	mVrms
Output impedance	Z _O		200	300	400	Ω
Delay time	T _{D-N}			63.44		μs
	T _{D-P}			63.88		μs

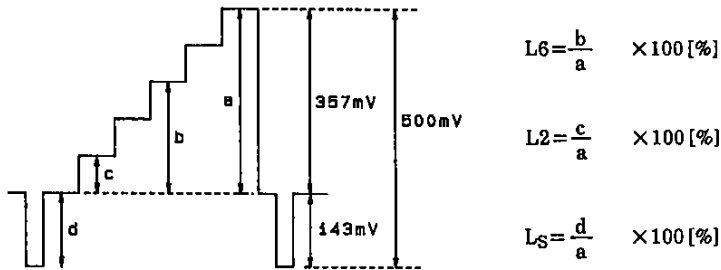

A03827

Note: * Input signal/output signal

Sample Application Circuit

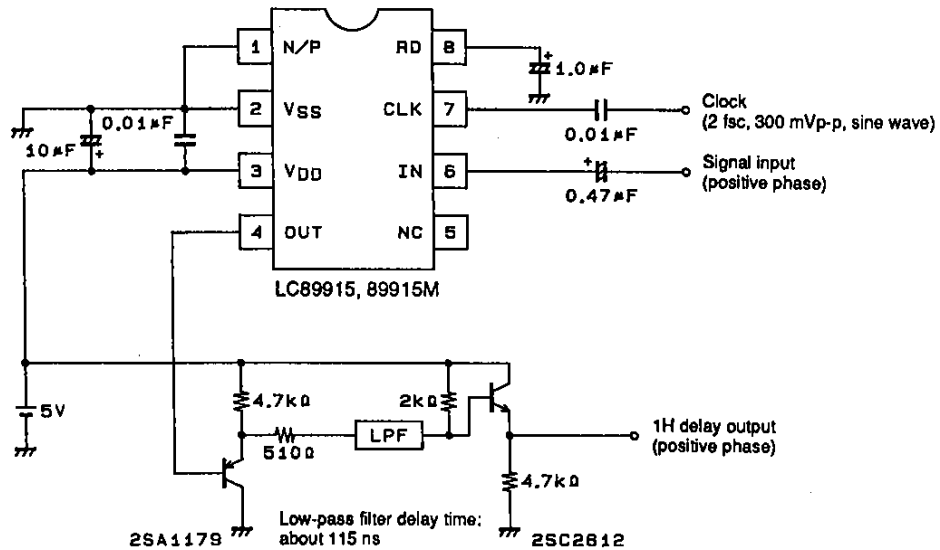

A03828

- No products described or contained herein are intended for use in surgical implants, life-support systems, aerospace equipment, nuclear power control systems, vehicles, disaster/crime-prevention equipment and the like, the failure of which may directly or indirectly cause injury, death or property loss.
- Anyone purchasing any products described or contained herein for an above-mentioned use shall:
 - ① Accept full responsibility and indemnify and defend SANYO ELECTRIC CO., LTD., its affiliates, subsidiaries and distributors and all their officers and employees, jointly and severally, against any and all claims and litigation and all damages, cost and expenses associated with such use:
 - ② Not impose any responsibility for any fault or negligence which may be cited in any such claim or litigation on SANYO ELECTRIC CO., LTD., its affiliates, subsidiaries and distributors or any of their officers and employees jointly or severally.
- Information (including circuit diagrams and circuit parameters) herein is for example only; it is not guaranteed for volume production. SANYO believes information herein is accurate and reliable, but no guarantees are made or implied regarding its use or any infringements of intellectual property rights or other rights of third parties.

This catalog provides information as of July, 1995. Specifications and information herein are subject to change without notice.