

TOSHIBA BIPOLAR LINEAR INTEGRATED CIRCUIT SILICON MONOLITHIC

**TA2149N, TA2149FN****3 V AM / FM 1 CHIP TUNER IC**

(for Digital Tuning System)

TA2149N, TA2149FN are AM / FM 1 chip tuner ICs, which are designed for portable Radios and 3 V Head phone Radios.

This is suitable for Digital Tuning System Applications. FM Local Oscillation Voltage is set up low relativity, for NEW FCC.

**FUNCTIONS**

- For NEW FCC.
- Suitable for combination with Digital Tuning System which is included IF Counter.
- One terminal type AM / FM IF count output for IF counter of Digital Tuning System.
  - FM : 1.3375 MHz (1 / 8 dividing)
  - AM : 450 kHz
- Built-in Mute Circuit for IF count output.
- For adopting ceramic Discriminator, it is not necessary to adjust the FM Quad Detector Circuit.
- Built-in FM MPX VCO circuit.
- Built-in one terminal type AM / FM Local Oscillator Buffer Output for Digital Tuning System Applications.
  - Built-in 1 / 16 Pre-scaler for FM Local OSC Buffer.
- Built-in AM Low cut circuit.
- Low supply current. ( $V_{CC} = 3 V$ ,  $T_a = 25^{\circ}C$ )
  - $I_{CCQ}$  (FM) = 13 mA (Typ.)
  - $I_{CCQ}$  (AM) = 8.5 mA (Typ.)
- Operating Supply voltage range :  $V_{CC} = 1.8 \sim 7 V$  ( $T_a = 25^{\circ}C$ )

(\*): Handle with care to prevent devices from deteriorations by static electricity.

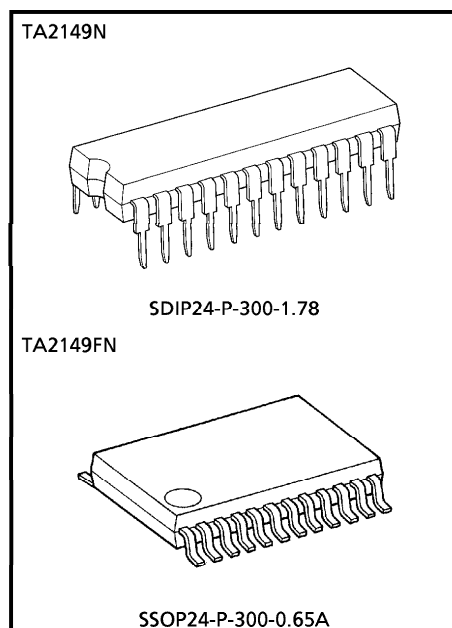

Weight  
SDIP24-P-300-1.78 : 1.2 g (Typ.)  
SSOP24-P-300-0.65A : 0.14 g (Typ.)

980910EBA1

- TOSHIBA is continually working to improve the quality and the reliability of its products. Nevertheless, semiconductor devices in general can malfunction or fail due to their inherent electrical sensitivity and vulnerability to physical stress. It is the responsibility of the buyer, when utilizing TOSHIBA products, to observe standards of safety, and to avoid situations in which a malfunction or failure of a TOSHIBA product could cause loss of human life, bodily injury or damage to property. In developing your designs, please ensure that TOSHIBA products are used within specified operating ranges as set forth in the most recent products specifications. Also, please keep in mind the precautions and conditions set forth in the TOSHIBA Semiconductor Reliability Handbook.
- The products described in this document are subject to the foreign exchange and foreign trade laws.
- The information contained herein is presented only as a guide for the applications of our products. No responsibility is assumed by TOSHIBA CORPORATION for any infringements of intellectual property or other rights of the third parties which may result from its use. No license is granted by implication or otherwise under any intellectual property or other rights of TOSHIBA CORPORATION or others.
- The information contained herein is subject to change without notice.

BLOCK DIAGRAM

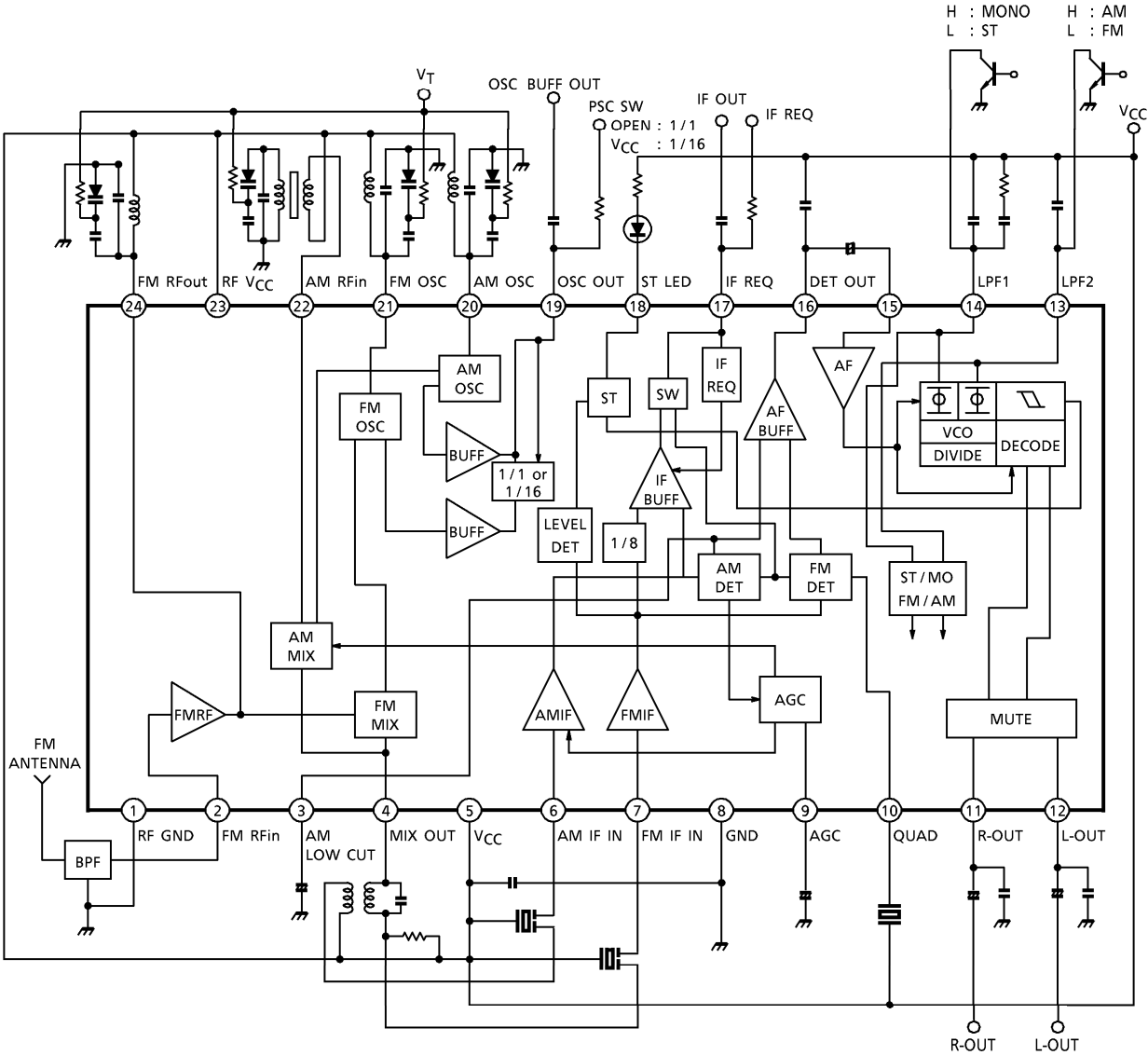

**EXPLANATION OF TERMINALS**

(Terminal Voltage : Typical terminal voltage at no signal with test circuit,  $V_{CC} = 3\text{ V}$ ,  $T_a = 25^\circ\text{C}$ )

PIN No.	CHARACTERISTIC	INTERNAL CIRCUIT	TERMINAL VOLTAGE (Typ.) (V)	
			AM	FM
1	RF GND (GND for FM RF stage)	—	0	0
2	FM-RFin		0	0.8
3	AM LOW CUT		1.0	—
4	MIX OUT		3.0	3.0
5	$V_{CC}$ ( $V_{CC}$ for AM, FM IF, FM MPX stage)	—	3.0	3.0
6	AM IF IN		2.3	2.5
7	FM IF IN		3.0	3.0

PIN No.	CHARACTERISTIC	INTERNAL CIRCUIT	TERMINAL VOLTAGE (Typ.) (V)	
			AM	FM
8	GND (GND for AM, FM IF, FM MPX stage)	—	0	0
9	AGC		0	0
10	QUAD		2.5	2.2
11 12	R-OUT L-OUT		1.2	1.2
13	<p>LPF2</p> <ul style="list-style-type: none"> <li>● LPF terminal for phase Detector.</li> <li>● Bias terminal AM / FM SW circuit.</li> </ul> <p>V<sub>13</sub> = GND → AM V<sub>13</sub> = OPEN → FM</p>		0	2.2

PIN No.	CHARACTERISTIC	INTERNAL CIRCUIT	TERMINAL VOLTAGE (Typ.) (V)	
			AM	FM
14	<p>LPF1</p> <ul style="list-style-type: none"> <li>● LPF terminal for Synchronous Detector.</li> <li>● V<sub>CO</sub> Stop terminal.</li> </ul> <p>V<sub>14</sub> = GND → V<sub>CO</sub> STOP</p>		0.7	2.4
15	MPX IN		0.7	0.7
16	DET OUT	<p>ⓐ LOW → FM, HIGH → AM          ⓑ LOW → AM, HIGH → FM</p>	1.0	0.9
17	IF REQ		—	—
18	ST LED		—	—

PIN No.	CHARACTERISTIC	INTERNAL CIRCUIT	TERMINAL VOLTAGE (Typ.) (V)	
			AM	FM
19	OSC OUT		2.8	2.7
20	AM OSC		3.0	3.0
21	FM OSC		3.0	3.0
22	AM RFin		3.0	3.0
23	RF VCC (VCC for FM RF stage)	—	3.0	3.0
24	FM RFout	Cf. pin ①	3.0	3.0

APPLICATION NOTE

1. AM Low-Cut Circuit

- The AM Low-Cut action is carried out by the bypass of the high frequency component of the positive-feedback signal at the AF AMP stage. The external capacitor : C<sub>3</sub> by-pass this component.
- The cut-off frequency f<sub>L</sub> is determined by the internal resistance 22 kΩ (Typ.) and the external capacitor C<sub>3</sub> as following ;

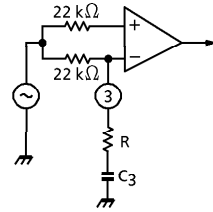

$$f_L = \frac{1}{2 \times \pi \times 22 \times 10^3 \times C_3} \text{ (Hz)}$$

- In the case of the AM Low-Cut function is not needed, set up the value of C<sub>3</sub> over 1 μF. In the condition of C<sub>3</sub> ≥ 1 μF, the frequency characteristic has flat response at the low frequency.
- It is possible to reduce the recovered output level at AM mode, by additional resistance between the pin ③ and GND line.

2. FM Detection Circuit

For the FM detection circuit, detection coil is able to use instead of ceramic discriminator. Recommended circuit and recommended coil are as follows. (In this case, please take care that V<sub>in</sub> (lim.) falls a little.)

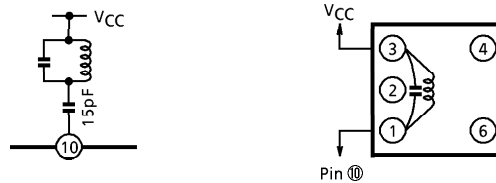

TEST FREQUENCY	C <sub>0</sub> (pF)	Q <sub>0</sub>	TURNS				WIRE (mm φ)	REFERENCE
			1-2	2-3	1-3	4-6		
10.7 MHz	51	45	—	—	30	—	0.08 UEW	TOKO Co., Ltd. 600BEAS-10018Z

3. FM/AM switch and forced monaural switch.

- FM/AM switchover and stereo/forced monaural switchover are done by pin ⑬ and pin ⑭.
- FM/AM switch (pin ⑬)  
 ( V13 : Low (Active Low, V<sub>th</sub> = 0.2 V (Typ.), I<sub>th</sub> 30 μA (Typ.) → AM )  
 ( V13 : OPEN → FM )
- Stereo/forced monaural switch (pin ⑭)  
 ( V14 : Low (Active Low, V<sub>th</sub> = 0.2 V (Typ.), I<sub>th</sub> 30 μA (Typ.) → Forced Monaural )  
 ( V14 : OPEN → Stereo )

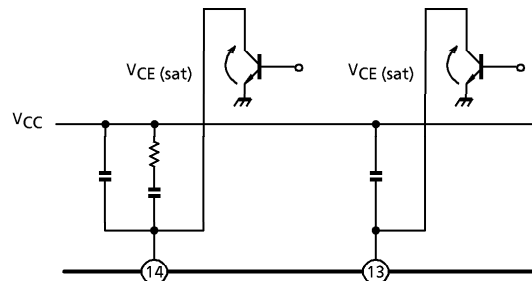

4. V<sub>CC</sub> Line

This ICs have two voltage supply terminals, V<sub>CC</sub> (for AM, FM IF, MPX stage) and RF V<sub>CC</sub> (for FM RF stage). Set up the potential difference between V<sub>CC</sub> and RF V<sub>CC</sub> 0.4 V (typ.) or less, otherwise there is the case that this IC doesn't operate normally.

5. How to control the Divider of FM OSC.

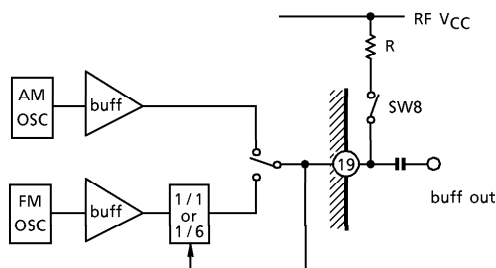

Divider of FM OSC ON/OFF switching is controlled by external pull-up resistor of pin ⑱. In case of Divider of FM OSC is used, it is necessary to set up the value of R under 470 Ω (typ.). When R is over 470 Ω, it is feared that Divider is not operating. (At this time, buffer output frequency is equal to FM OSC frequency.) Which ever Divider of FM OSC is used or not, AM OSC buffer frequency and output level is same.

MODE	SW8	OUTPUT FREQUENCY	OUTPUT LEVEL (TYP.)
FM	OPEN	1 / 1 FM OSC	35 mV <sub>rms</sub>
	ON	1 / 16 FM OSC	110 mV <sub>rms</sub>
AM	OPEN	1 / 1 AM OSC	75 mV <sub>rms</sub>
	ON		

MAXIMUM RATINGS (Ta = 25°C)

CHARACTERISTIC	SYMBOL	RATING	UNIT
Supply Voltage	V <sub>CC</sub>	8	V
LED Current	I <sub>LED</sub>	10	mA
LED Voltage	V <sub>LED</sub>	8	V
Power Dissipation	P <sub>D</sub> (Note)	1200	mW
		500	
Operating Temperature	T <sub>opr</sub>	- 25~75	°C
Storage Temperature	T <sub>stg</sub>	- 55~150	°C

(Note) : Derated above Ta = 25°C in the proportion of 9.6 mW/°C for TA2149N of 4 mW/°C for TA2149FN.



## ELECTRICAL CHARACTERISTICS

Unless otherwise specified, Ta = 25°C, VCC = 3 V, F/E : f = 98 MHz, fm = 1 kHz  
 FM IF : f = 10.7 MHz, Δf = ±75 kHz, fm = 1 kHz  
 AM : f = 1 MHz, MOD = 30%, fm = 1 kHz  
 MPX : fm = 1 kHz

CHARACTERISTIC		SYMBOL	TEST CIRCUIT	TEST CONDITION	MIN.	TYP.	MAX.	UNIT
Supply Current		ICC (FM)	—	Vin = 0, FM mode	—	13	16.5	mA
		ICC (AM)	—	Vin = 0, AM mode	—	8.5	11.0	
F/E	Input Limiting Voltage	Vin (lim)	—	Vin = 60 dBμV EMF, -3 dB limiting	—	10	—	dBμV EMF
	Local OSC Buffer Output Voltage 1	VOSC (buff) FM1	—	fOSC = 108.7 MHz	23	35	—	mVrms
	Local OSC Buffer Output Voltage 2	VOSC (buff) FM2	—	fOSC = 6.79375 MHz SW8 : ON	75	110	—	mVrms
FM IF	Input Limiting Voltage	Vin (lim) IF	—	Vin = 80 dBμV EMF, -3 dB limiting	35	40	45	dBμV EMF
	Recovered Output Voltage	VOD	—	Vin = 80 dBμV EMF	200	250	300	mVrms
	Signal To Noise Ratio	S/N	—	Vin = 80 dBμV EMF	—	75	—	dB
	Total Harmonic Distortion	THD	—	Vin = 80 dBμV EMF	—	0.3	—	%
	AM Rejection Ration	AMR	—	Vin = 80 dBμV EMF	—	60	—	dB
	IF Count Output Frequency	fIF (FM)	—	Vin = 80 dBμV EMF, SW7 : ON	1.3373	1.3375	1.3377	MHz
	IF Count Output Voltage	VIF (FM)	—	Vin = 80 dBμV EMF, SW7 : ON	200	260	—	mVp-p
	IF Count Output Sensitivity	IF sens (FM)	—	SW7 : ON	47	52	57	dBμV EMF
AM	Gain	Gv	—	Vin = 27 dBμV EMF	20	38	70	mVrms
	Recovered Output Voltage	VOD	—	Vin = 60 dBμV EMF	60	85	108	mVrms
	Signal To Noise Ratio	S/N	—	Vin = 60 dBμV EMF	—	41	—	dB
	Total Harmonic Distortion	THD	—	Vin = 60 dBμV EMF	—	0.7	—	%
	Local OSC Buffer Output Voltage	VOSC (buff) AM	—	fOSC = 1.45 MHz	55	75	—	mVrms
	IF Count Output Voltage	VIF (AM)	—	Vin = 60 dBμV EMF, SW7 : ON	200	250	—	mVp-p
	IF Count Output Sensitivity	IF sens (AM)	—	SW7 : ON	34	39	44	dBμV EMF
PIN ⑰ Output Resistance		R17	—	FM mode	—	0.75	—	kΩ
				AM mode	—	15.5	—	

CHARACTERISTIC		SYMBOL	TEST CIRCUIT	TEST CONDITION	MIN.	TYP.	MAX.	UNIT	
MPX	Input Resistance	R <sub>IN</sub>	—	—	—	55	—	kΩ	
	Output Resistance	R <sub>OUT</sub>	—	—	—	5	—	kΩ	
	Max. Composite Signal Input Voltage	V <sub>in</sub> MAX (Stereo)	—	L + R = 90%, P = 10%, SW3 : LPF ON f <sub>m</sub> = 1 kHz, THD = 3%	—	700	—	mV <sub>rms</sub>	
	Separation	Sep.	—	L + R = 180 mV <sub>rms</sub> , P = 20 mV <sub>rms</sub> SW3 : LPF ON	f <sub>m</sub> = 100 Hz	—	45	—	dB
					f <sub>m</sub> = 1 kHz	35	45	—	
					f <sub>m</sub> = 10 kHz	—	45	—	
	Total Harmonic Distortion	Monaural	THD (Monaural)	—	V <sub>in</sub> = 200 mV <sub>rms</sub>	—	0.3	—	%
		Stereo	THD (Stereo)	—	L + R = 180 mV <sub>rms</sub> , P = 20 mV <sub>rms</sub> , SW3 : LPF ON	—	0.3	—	
	Voltage Gain		G <sub>V</sub>	—	V <sub>in</sub> = 200 mV <sub>rms</sub>	-2.7	-1.2	0.2	dB
	Channel Balance		C.B.	—	V <sub>in</sub> = 200 mV <sub>rms</sub>	-1.5	0	1.5	dB
	Stereo LED Sensitivity	ON	V <sub>L</sub> (ON)	—	Pilot Input (19 kHz)	—	10	14	mV <sub>rms</sub>
		OFF	V <sub>L</sub> (OFF)	—		5	8	—	
Stereo LED Hysteresis		V <sub>H</sub>	—	To LED turn off from LED turn on	—	2	—	mV <sub>rms</sub>	
Capture Range		C.R.	—	P = 15 mV <sub>rms</sub>	—	±8	—	%	
Signal Noise Ratio		S/N	—	V <sub>in</sub> = 200 mV <sub>rms</sub>	—	80	—	dB	
Muting Attenuation		MUTE	—	V <sub>in</sub> = 200 mV <sub>rms</sub>	—	80	—	dB	

**COIL DATA**

COIL No.	TEST FREQ	L (μH)	Co (pF)	Qo	TURNS					WIRE (mmφ)	REFERENCE
					1-2	2-3	1-3	1-4	4-6		
L <sub>1</sub> FM RF	100 MHz			79			2 $\frac{1}{2}$			0.16UEW	TOKO Co., Ltd. 666SNF-305NK
L <sub>2</sub> FM OSC	100 MHz			76			2			0.16UEW	TOKO Co., Ltd. 666SNF-306NK
T <sub>1</sub> AM OSC	796 kHz	268	—	65	19	95				0.05UEW	TOKO Co., Ltd. 5PNR-5146Y
T <sub>2</sub> AM IFT	455 kHz	—	470	60			109		7	0.05UEW	TOKO Co., Ltd. 5PLG-5147X

L<sub>1</sub> : FM RF

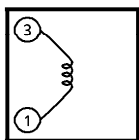

L<sub>2</sub> : FM OSC

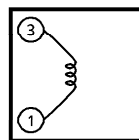

T<sub>1</sub> : AM OSC

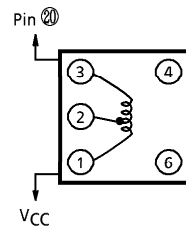

T<sub>2</sub> : AM IFT

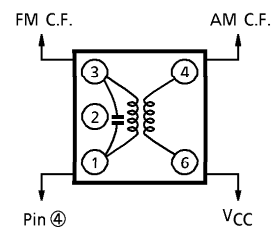

TEST CIRCUIT

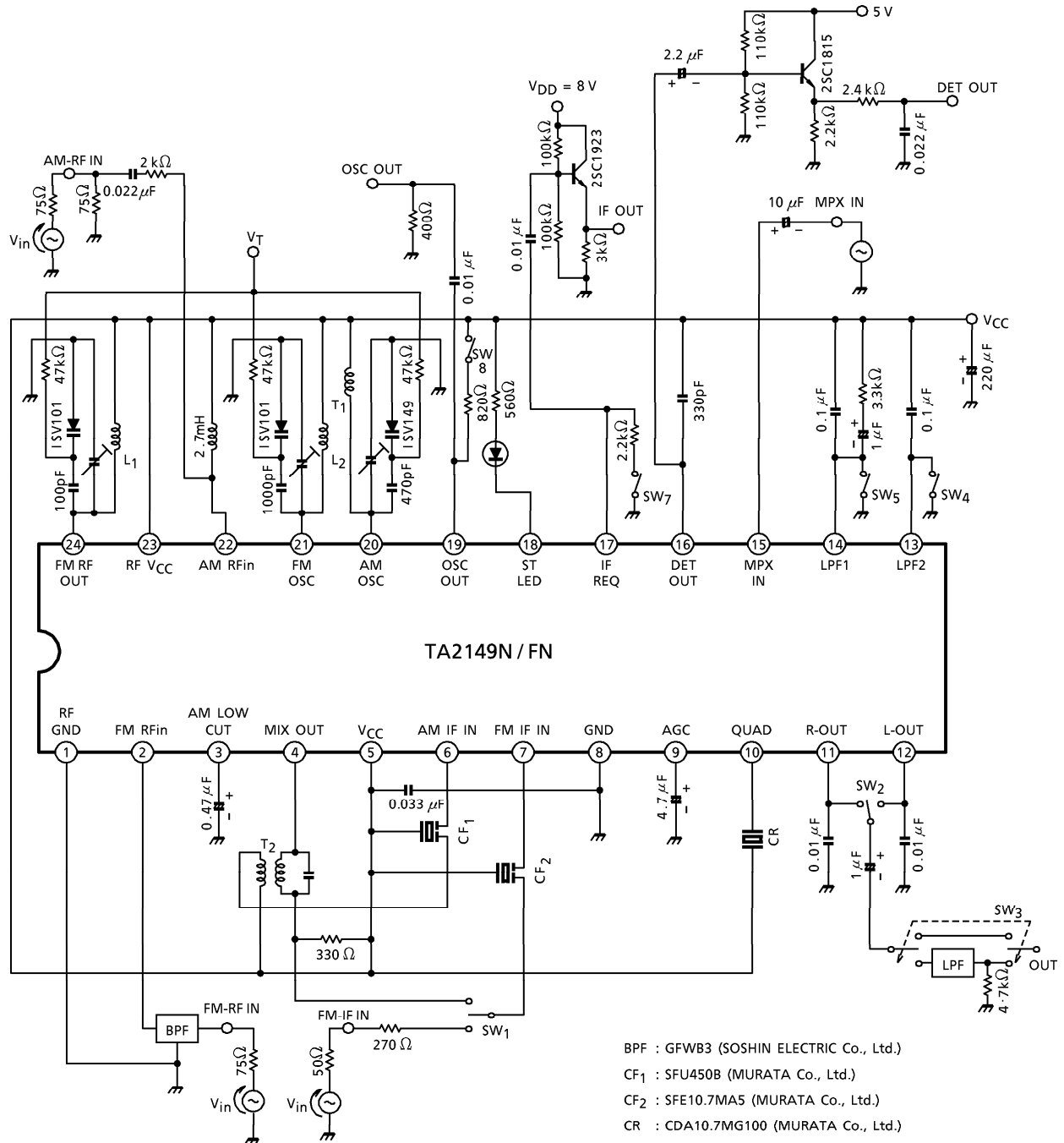

PACKAGE DIMENSIONS  
SDIP24-P-300-1.78

Unit : mm

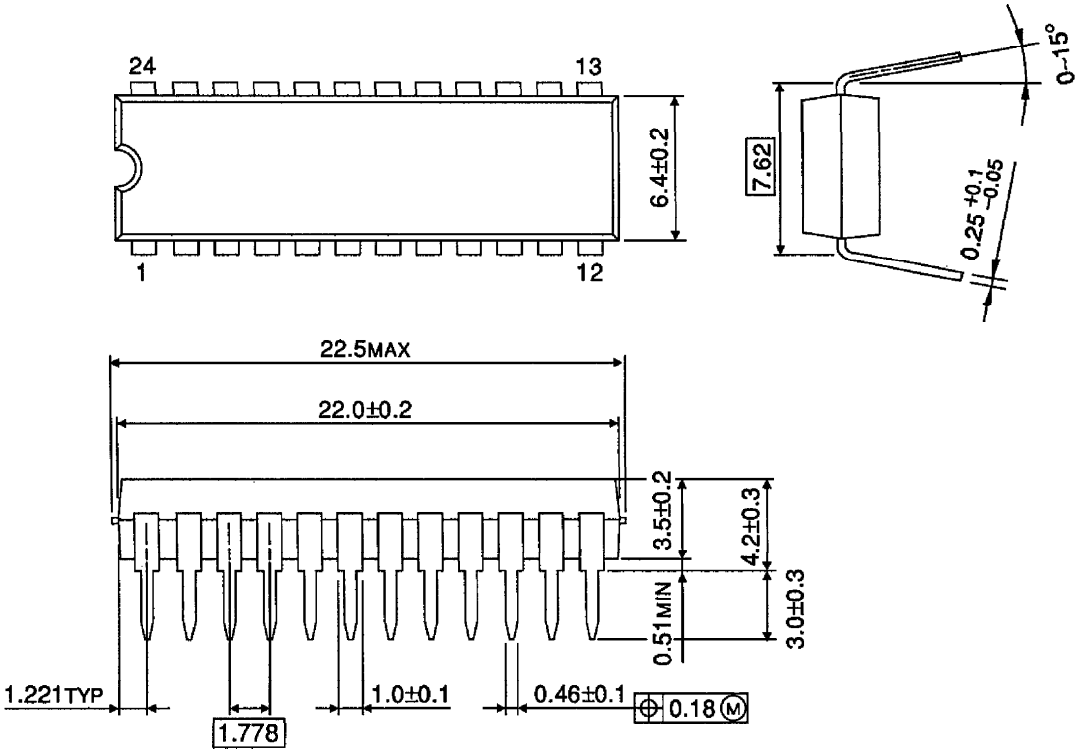

Weight : 1.2 g (Typ.)

PACKAGE DIMENSIONS  
SSOP24-P-300-0.65A

Unit : mm

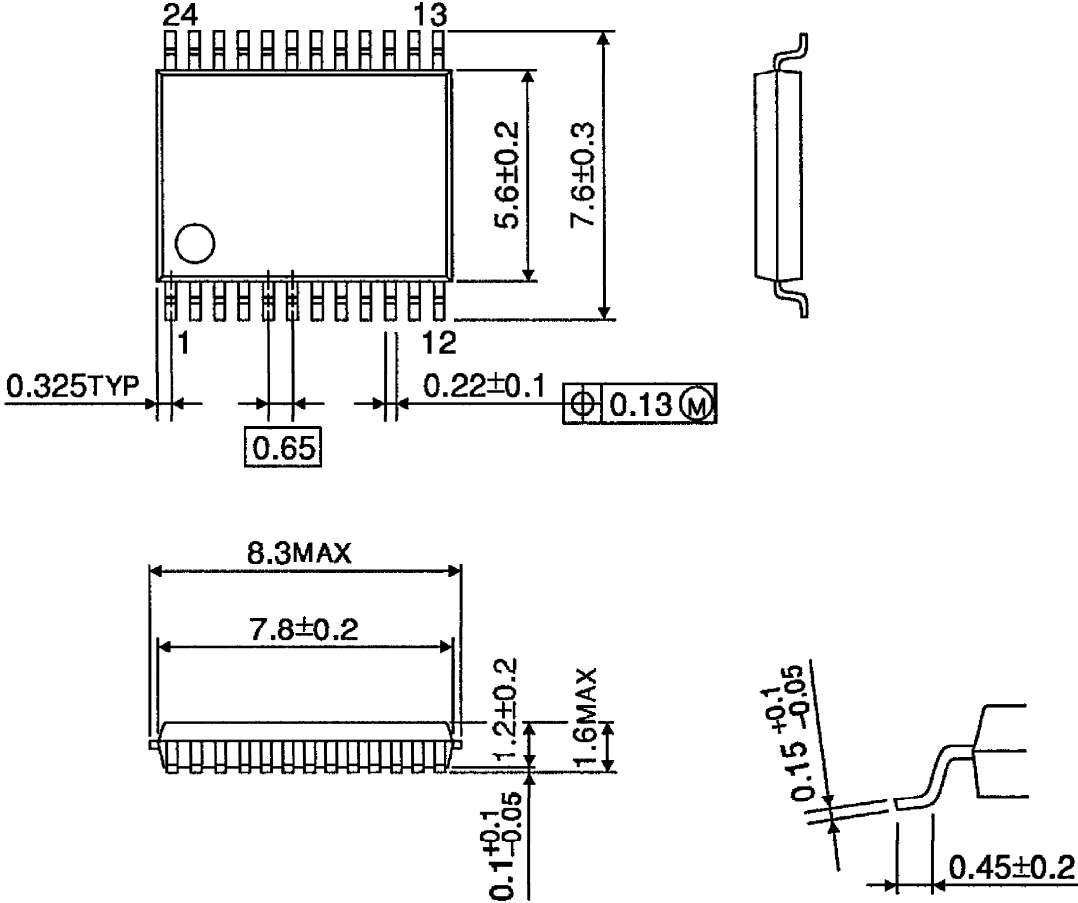

Weight : 0.14 g (Typ.)