

PROGRAMMABLE LOW POWER SINGLE OPERATIONAL AMPLIFIERS

- MICROPOWER OPERATION
- NO FREQUENCY COMPENSATION REQUIRED
- WIDE PROGRAMMING RANGE
- HIGH SLEW RATE
- SHORT-CIRCUIT PROTECTION
- PROGRAMMABLE SINGLE OP-AMP

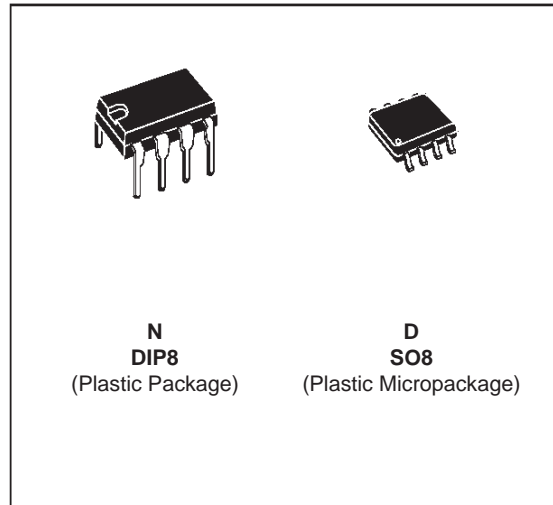

ORDER CODES

Part Number	Temperature Range	Package	
		N	D
UA776C	0°C, +70°C	•	•
UA776I	-40°C, +105°C	•	•
UA776M	-55°C, +125°C	•	•

Example : UA776CN

DESCRIPTION

The UA776 programmable operational amplifier is characterized by low supply current and low equivalent input noise voltage over a wide range of operating supply voltages.

Coupled with programmable electrical characteristics, it is a versatile amplifier for use in high accuracy, low power consumption analog applications.

Input noise voltage and current, power consumption and input current can be optimized by a single resistor or current source that sets the chip quiescent current for nano-watt power consumption or for characteristics similar to the UA741.

Internal frequency compensation, absence of latch up, high slew rate and short-circuit protection assure ease of use in long time integrators, active filters, and sample and hold circuits.

PIN CONNECTIONS (top view)

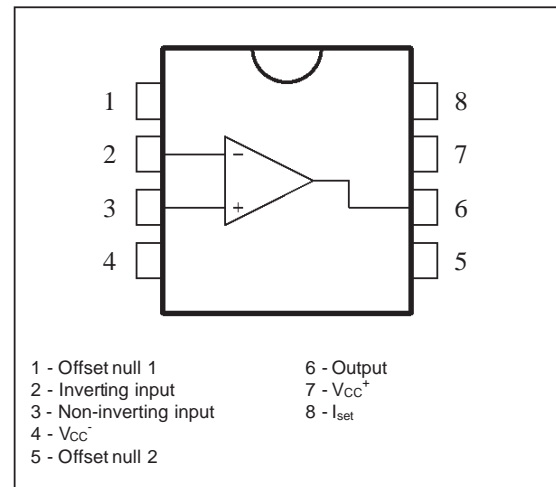

SCHEMATIC DIAGRAM

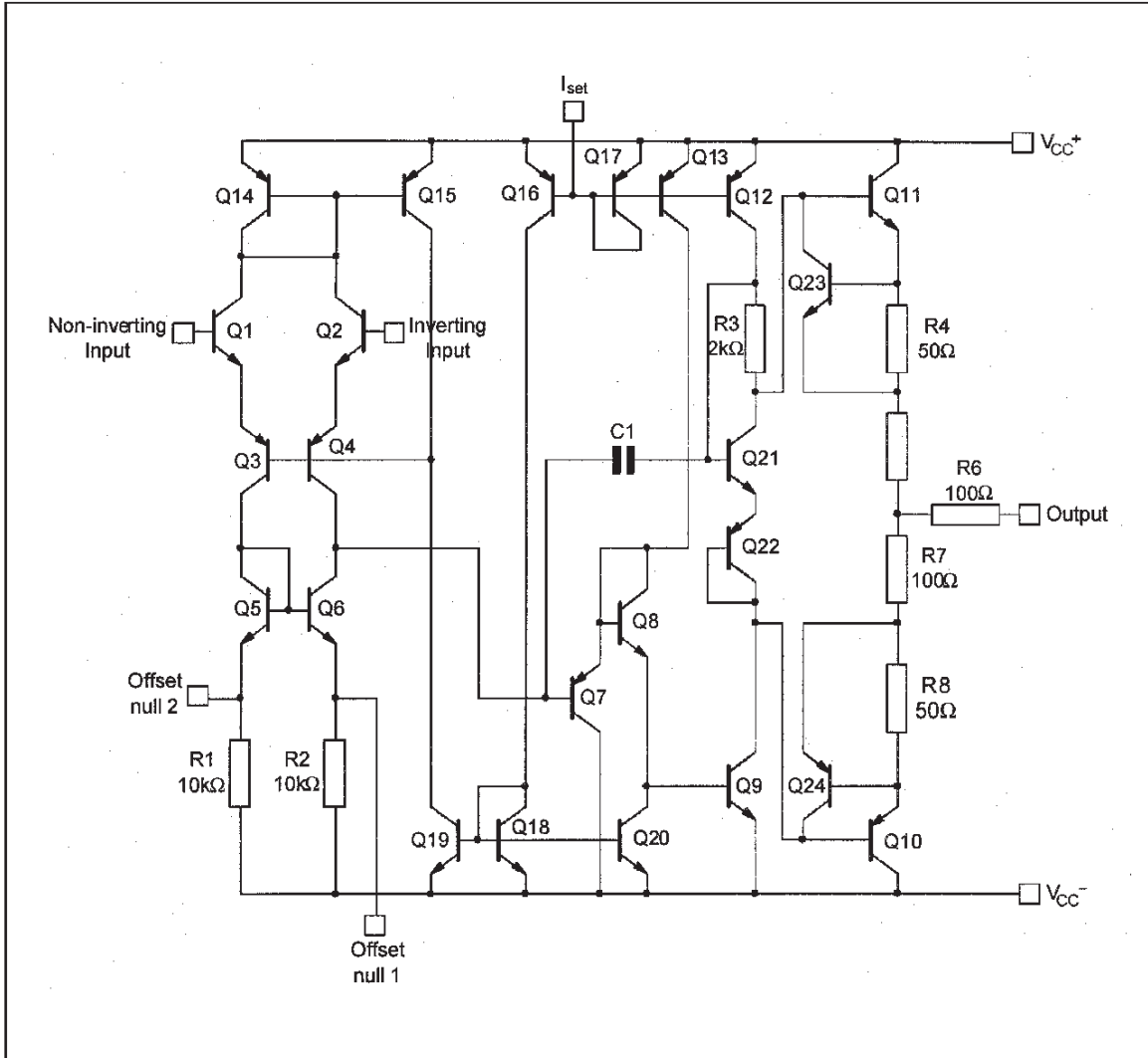

ABSOLUTE MAXIMUM RATINGS

Symbol	Parameter	UA776M	UA776I	UA776C	Unit
V_{cc}	Supply Voltage		± 18		V
V_{id}	Differential Input Voltage		± 30		V
V_i	Input Voltage - (note 1)		± 15		V
P_{tot}	Power Dissipation	500	310	310	mW
	Output Short-circuit Duration		Infinite		
T_{oper}	Operating Free Air Temperature Range	-55 to +125	-40 to +105	0 to +70	$^{\circ}C$
T_{stg}	Storage Temperature Range	-65 to +150	-65 to +150	-65 to +150	$^{\circ}C$

Note : 1. For supply voltages less than $\pm 15V$, the absolute maximum input voltage is equal to the supply voltage.

ELECTRICAL CHARACTERISTICS $V_{CC} \pm 15V, T_{amb} = +25^{\circ}C$ (unless otherwise specified)

Symbol	Parameter	$I_{set} = 1.5\mu A$			$I_{set} = 15\mu A$			Unit
		Min.	Typ.	Max.	Min.	Typ.	Max.	
V_{io}	Input Offset Voltage $T_{amb} = +25^{\circ}C$ $T_{min.} \leq T_{amb} \leq T_{max.}$		2	5 6		2	5 6	mV
I_{io}	Input Offset Current $T_{amb} = +25^{\circ}C$ $T_{min.} \leq T_{amb} \leq T_{max.}$		0.7	3 10		2	15 40	nA
I_{ib}	Input Bias Current $T_{amb} = +25^{\circ}C$ UA776M UA776L,C $T_{min.} \leq T_{amb} \leq T_{max.}$		2 2	7.5 10 20		15 15	50 50 100	nA
A_{vd}	Large Signal Voltage Gain ($V_O \pm 10V$) $T_{amb} = +25^{\circ}C$ $R_L = 75k\Omega$ $T_{min.} \leq T_{amb} \leq T_{max.}$ $R_L = 5k\Omega$ $R_L = 75k\Omega$	200 100	400		100 75	400		V/mV
SVR	Supply Voltage Rejection Ratio ($R_S \leq 10k\Omega$) $T_{amb} = +25^{\circ}C$ $T_{min.} \leq T_{amb} \leq T_{max.}$	77 77	92		77 77	92		dB
I_{CC}	Supply Current, no load $T_{amb} = +25^{\circ}C$ $T_{min.} \leq T_{amb} \leq T_{max.}$		20	25 30		160	180 200	μA
V_{icm}	Input Common Mode Voltage Range	± 10			± 10			V
CMR	Common-mode Rejection Ratio ($R_S \leq 10k\Omega$) $T_{amb} = +25^{\circ}C$ $T_{min.} \leq T_{amb} \leq T_{max.}$	70 70	90		70 70	90		dB
I_{OS}	Output Short-circuit Current	0.5	3	15	6	12	30	mA
$\pm V_{OPP}$	Output Voltage Swing $T_{amb} = +25^{\circ}C$ $R_L = 75k\Omega$ $T_{min.} \leq T_{amb} \leq T_{max.}$ $R_L = 5k\Omega$ $R_L = 75k\Omega$	12 10	14		10 10	13		V
V_{ior}	Offset Voltage Adjustment Range		9			18		mV
SR	Slew Rate ($V_i = \pm 10V, C_L = 100pF$, unity gain) $R_L = 5k\Omega$ $R_L = 75k\Omega$	0.01	0.1		0.2	0.8		V/ms
t_r	Rise Time ($V_i = \pm 20mV, C_L = 100pF$, unity gain) $R_L = 5k\Omega$ $R_L = 75k\Omega$		1.6			0.35		ms
K_{OV}	Overshoot ($V_i = \pm 20mV, C_L = 100pF$, unity gain) $R_L = 5k\Omega$ $R_L = 75k\Omega$		0			10		%
R_I	Input Resistance		50			5		$M\Omega$
C_{id}	Differential Input Capacitance		2			2		pF
R_O	Output Resistance		5			1		$k\Omega$
GBP	Gain Bandwidth Product ($C_L = 100pF, T_{amb} = 25^{\circ}C$) $f = 100kHz$ $f = 10kHz$ $R_L = 5k\Omega$ $R_L = 75k\Omega$	0.3	0.1		0.4	0.7		MHz
THD	Total Harmonic Distortion ($f = 1kHz, A_V = 20dB$, $V_O = 2V_{PP}, C_L = 100pF, T_{amb} = 25^{\circ}C$) $R_L = 5k\Omega$ $R_L = 75k\Omega$		0.8			0.025		%
e_n	Equivalent Input Noise Voltage ($f = 1kHz, R_S = 100\Omega$)		40			20		$\frac{nV}{\sqrt{Hz}}$

ELECTRICAL CHARACTERISTICS $V_{CC} \pm 3V$, $T_{amb} = +25^{\circ}C$ (unless otherwise specified)

Symbol	Parameter	$I_{set} = 1.5\mu A$			$I_{set} = 15\mu A$			Unit
		Min.	Typ.	Max.	Min.	Typ.	Max.	
V_{io}	Input Offset Voltage $T_{amb} = +25^{\circ}C$ $T_{min.} \leq T_{amb} \leq T_{max.}$		2	5 6		2	5 6	mV
I_{io}	Input Offset Current $T_{amb} = +25^{\circ}C$ $T_{min.} \leq T_{amb} \leq T_{max.}$		0.7	3 10		2	15 40	nA
I_{ib}	Input Bias Current $T_{amb} = +25^{\circ}C$ UA776M UA776I,C $T_{min.} \leq T_{amb} \leq T_{max.}$		2 2	7 10 20		15 15	50 50 100	nA
A_{vd}	Large Signal Voltage Gain ($V_O \pm 10V$) $T_{amb} = +25^{\circ}C$ $R_L = 75k\Omega$ $T_{min.} \leq T_{amb} \leq T_{max.}$ $R_L = 5k\Omega$	50 25	200		50 25	200		V/mV
SVR	Supply Voltage Rejection Ratio ($R_S \leq 10k\Omega$) $T_{amb} = +25^{\circ}C$ $T_{min.} \leq T_{amb} \leq T_{max.}$	77 77	92		77 77	92		dB
I_{CC}	Supply Current, no load $T_{amb} = +25^{\circ}C$ $T_{min.} \leq T_{amb} \leq T_{max.}$		13	20 25		130	160 180	μA
V_{icm}	Input Common Mode Voltage Range	± 1			± 1			V
CMR	Common-mode Rejection Ratio ($R_S \leq 10k\Omega$) $T_{amb} = +25^{\circ}C$ $T_{min.} \leq T_{amb} \leq T_{max.}$	70 70	90		70 70	90		dB
I_{OS}	Output Short-circuit Current	0.5	3	15	2	5	20	mA
$\pm V_{OPP}$	Output Voltage Swing $T_{amb} = +25^{\circ}C$ $R_L = 75k\Omega$ $R_L = 5k\Omega$ $T_{min.} \leq T_{amb} \leq T_{max.}$ $R_L = 75k\Omega$ $R_L = 5k\Omega$	2 2	2.4		2 1.9 2 1.9	2.4 2.1		V
V_{ioR}	Offset Voltage Adjustment Range		9			18		mV
SR	Slew Rate ($V_i = \pm 10V$, $C_L = 100pF$, unity gain) $R_L = 5k\Omega$ $R_L = 75k\Omega$		0.03			0.35		V/ms
t_r	Rise Time ($V_i = \pm 20mV$, $C_L = 100pF$, unity gain) $R_L = 5k\Omega$ $R_L = 75k\Omega$		3			0.6		μs
K_{OV}	Overshoot ($V_i = \pm 20mV$, $C_L = 100pF$, unity gain) $R_L = 5k\Omega$ $R_L = 75k\Omega$		0			5		%
R_i	Input Resistance		50			5		$M\Omega$
C_{id}	Differential Input Capacitance		2			2		pF
R_o	Output Resistance		5			1		k Ω
GBP	Gain Bandwidth Product ($C_L = 100pF$, $T_{amb} = 25^{\circ}C$) $f = 100kHz$ $f = 10kHz$ $R_L = 5k\Omega$ $R_L = 75k\Omega$		0.075			0.5		MHz
THD	Total Harmonic Distortion ($f = 1kHz$, $A_V = 20dB$, $V_O = 2V_{PP}$, $C_L = 100pF$, $T_{amb} = 25^{\circ}C$) $R_L = 5k\Omega$ $R_L = 75k\Omega$		1			0.03		%
en	Equivalent Input Noise Voltage ($f = 1kHz$, $R_S = 100\Omega$)		20			20		$\frac{nV}{\sqrt{Hz}}$

BIASING CIRCUITS

RESISTOR BIASING

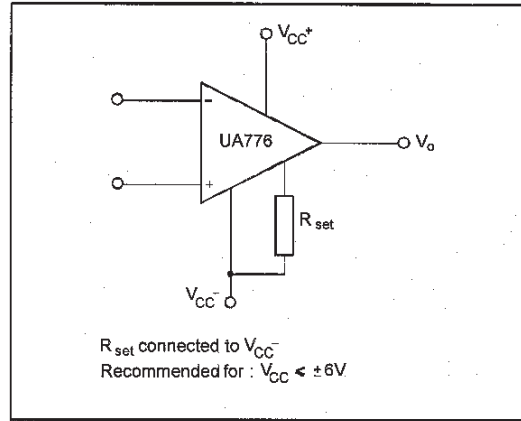
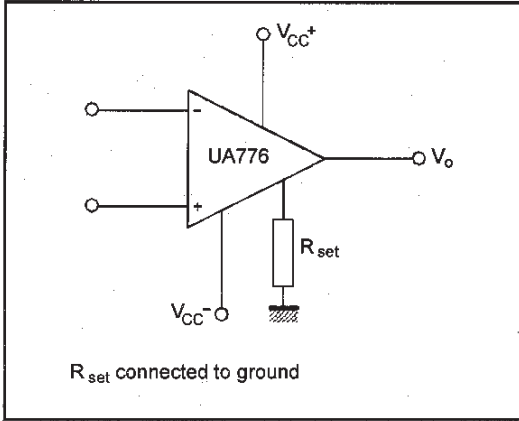

TRANSISTOR CURRENT SOURCE BIASING

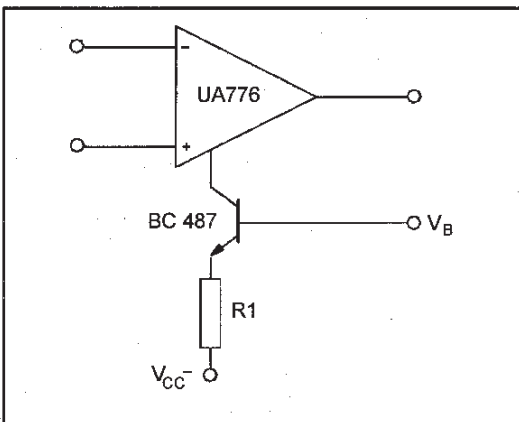

FET CURRENT SOURCE BIASING

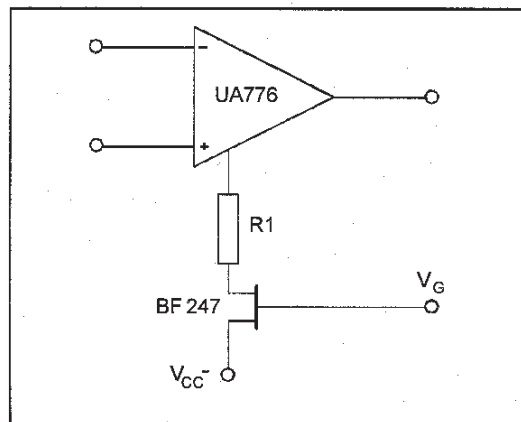

OFFSET VOLTAGE NULL CIRCUIT

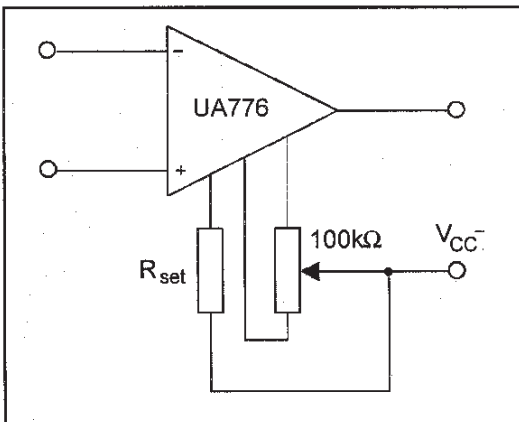

TRANSIENT RESPONSE TIME TEST CIRCUIT

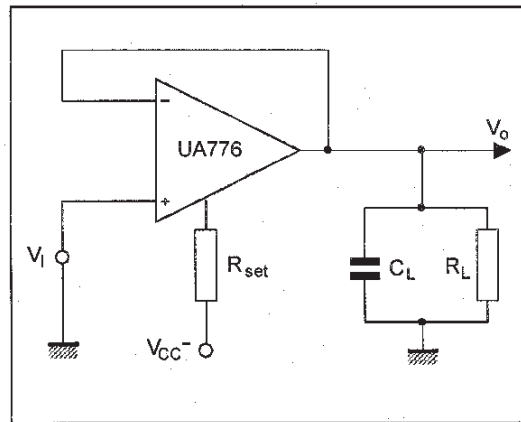

TYPICAL APPLICATIONS

HIGH ACCURACY SAMPLE AND HOLD

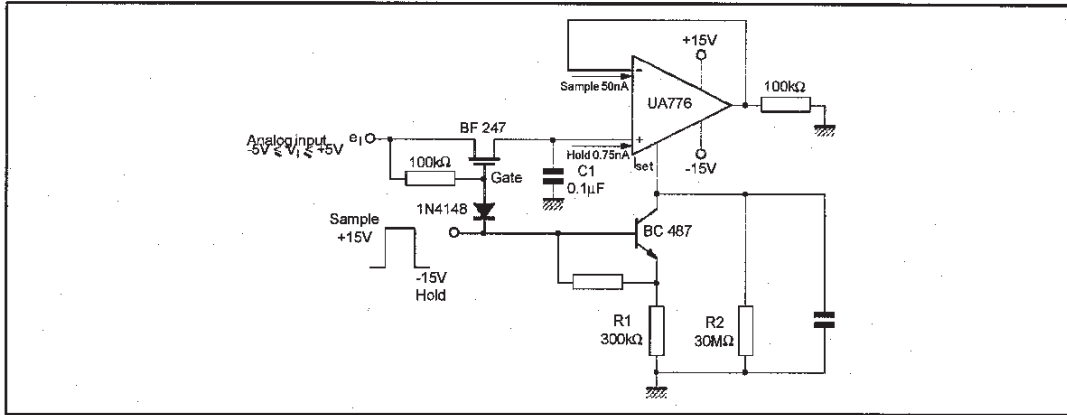

776-10.EPS

MULTIPLEXING AND SIGNAL CONDITIONING WITHOUT FETs

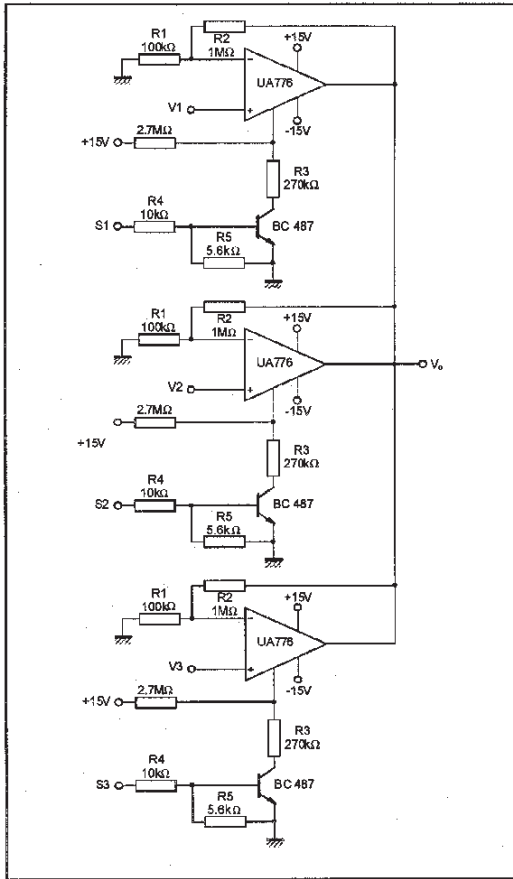

776-11.EPS

NANO-WATT AMPLIFIER

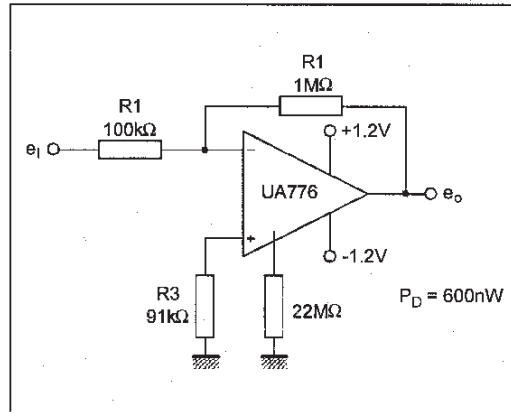

776-12.EPS

HIGH INPUT IMPEDANCE AMPLIFIER

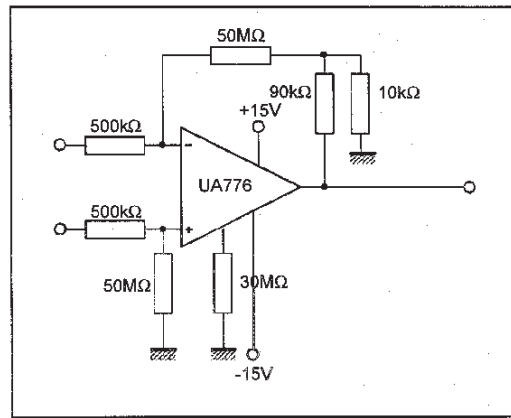

776-13.EPS

PACKAGE MECHANICAL DATA
8 PINS - PLASTIC DIP

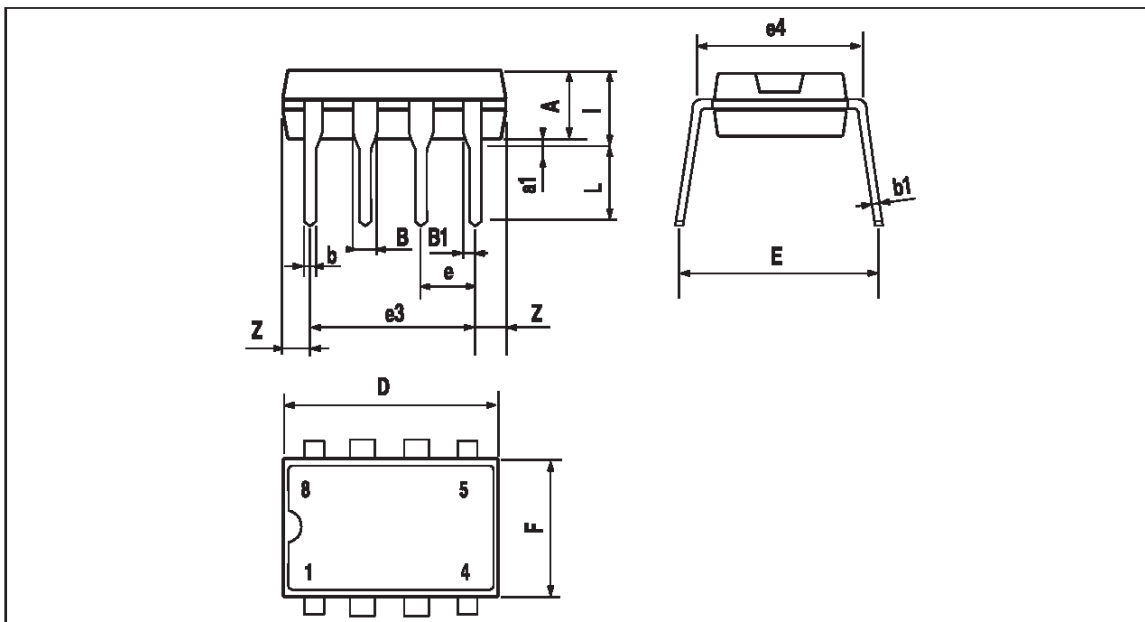

Dim.	Millimeters			Inches		
	Min.	Typ.	Max.	Min.	Typ.	Max.
A		3.32			0.131	
a1	0.51			0.020		
B	1.15		1.65	0.045		0.065
b	0.356		0.55	0.014		0.022
b1	0.204		0.304	0.008		0.012
D			10.92			0.430
E	7.95		9.75	0.313		0.384
e		2.54			0.100	
e3		7.62			0.300	
e4		7.62			0.300	
F			6.6			0.260
i			5.08			0.200
L	3.18		3.81	0.125		0.150
Z			1.52			0.060

1

PACKAGE MECHANICAL DATA
8 PINS - PLASTIC MICROPACKAGE (SO)

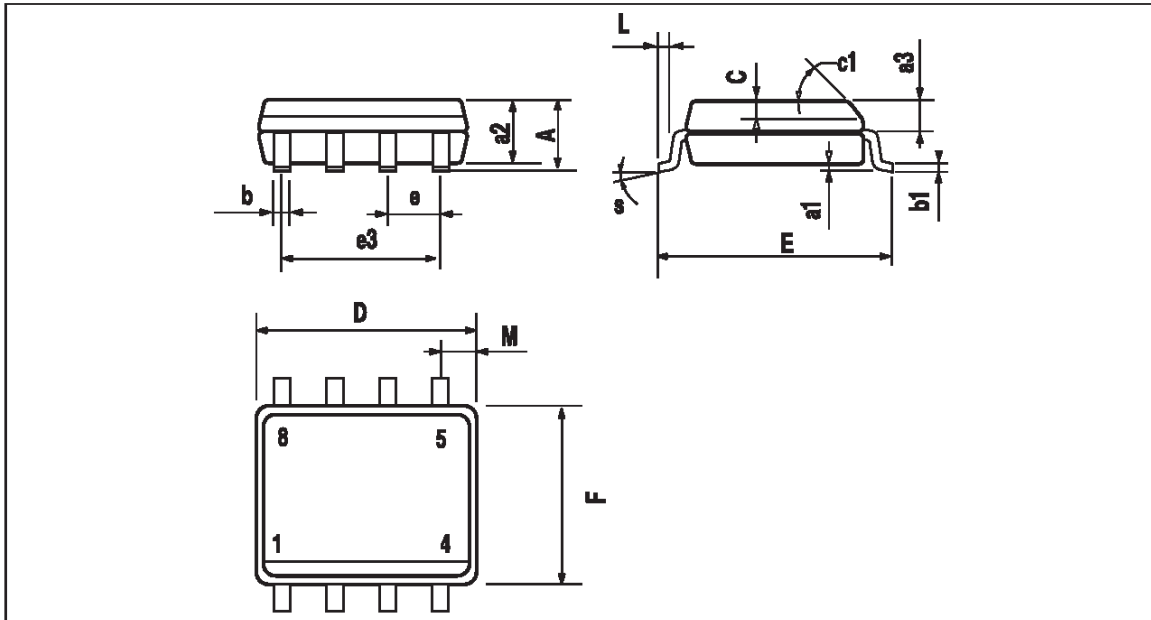

Dim.	Millimeters			Inches		
	Min.	Typ.	Max.	Min.	Typ.	Max.
A			1.75			0.069
a1	0.1		0.25	0.004		0.010
a2			1.65			0.065
a3	0.65		0.85	0.026		0.033
b	0.35		0.48	0.014		0.019
b1	0.19		0.25	0.007		0.010
C	0.25		0.5	0.010		0.020
c1	45° (typ.)					
D	4.8		5.0	0.189		0.197
E	5.8		6.2	0.228		0.244
e		1.27			0.050	
e3		3.81			0.150	
F	3.8		4.0	0.150		0.157
L	0.4		1.27	0.016		0.050
M			0.6			0.024
S	8° (max.)					

1

Information furnished is believed to be accurate and reliable. However, SGS-THOMSON Microelectronics assumes no responsibility for the consequences of use of such information nor for any infringement of patents or other rights of third parties which may result from its use. No license is granted by implication or otherwise under any patent or patent rights of SGS-THOMSON Microelectronics. Specifications mentioned in this publication are subject to change without notice. This publication supersedes and replaces all information previously supplied. SGS-THOMSON Microelectronics products are not authorized for use as critical components in life support devices or systems without express written approval of SGS-THOMSON Microelectronics.

© 1997 SGS-THOMSON Microelectronics – Printed in Italy – All Rights Reserved

SGS-THOMSON Microelectronics GROUP OF COMPANIES
Australia - Brazil - Canada - China - France - Germany - Italy - Japan - Korea - Malaysia - Malta - Morocco
The Netherlands - Singapore - Spain - Sweden - Switzerland - Taiwan - Thailand - United Kingdom - U.S.A.