

KA2211

LINEAR INTEGRATED CIRCUIT

5.8W DUAL POWER AMPLIFIER

The KA2211 is a dual audio power amplifier for consumer application. It is designed for high power, low dissipation and low noise.

It also contains various kind of protectors. It is suitable for car-audio power amplifier with high performance.

FEATURES

- Operating supply voltage range: $V_{CC} = 10V \sim 18V$
- High power (Dual)
 $P_o = 5.8W$ (Typ) at $V_{CC} = 13.2V$, $R_L = 4\Omega$, THD = 10%
- Low distortion (Dual)
THD = 0.06% (Typ) at $V_{CC} = 13.2V$, $R_L = 4\Omega$, $P_o = 1W$, $A_V = 52dB$
- Low noise (Dual)
 $V_{NO} = 0.7mV$ (Typ) at $V_{CC} = 13.2V$, $R_L = 4\Omega$, $R_g = 10K\Omega$,
 $A_V = 52dB$, BW(-3dB) = 20Hz ~ 20KHz
- Protector; Thermal shut down
Over voltage protection
DC short protection

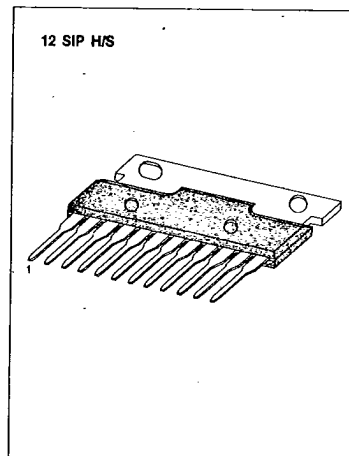

3

BLOCK DIAGRAM

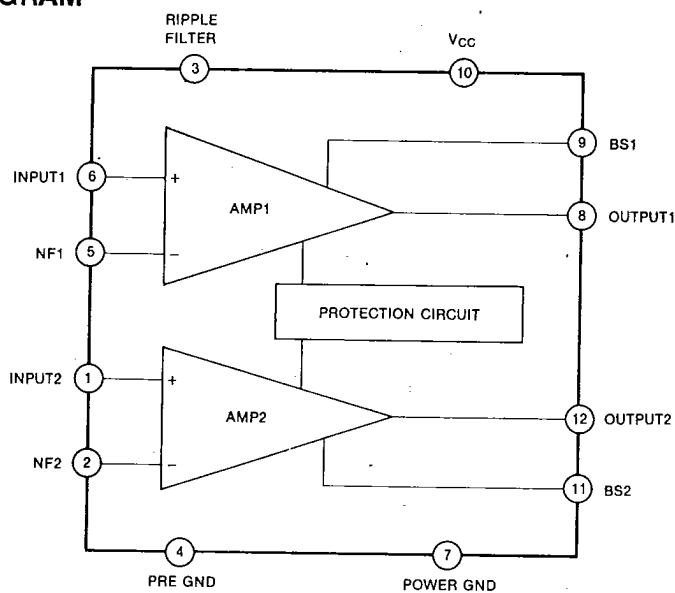

Fig. 1

KA2211

LINEAR INTEGRATED CIRCUIT

ABSOLUTE MAXIMUM RATINGS ($T_a = 25^\circ\text{C}$)

Characteristic	Symbol	Condition	Value	Unit
Supply Voltage	V_{CC} (surge)	$t = 0.2$ sec	45	V
Maximum Supply Voltage	V_{CC} (max 1)	$V_i = 0$	25	V
Maximum Supply Voltage	V_{CC} (max 2)	with signal	18	V
Maximum Output Current	I_o (peak)		3.5	A
Power Dissipation	P_d		15	W
Operating Temperature	T_{opr}		$-20 \sim +75$	$^\circ\text{C}$
Storage Temperature	T_{stg}		$-40 \sim +150$	$^\circ\text{C}$

ELECTRICAL CHARACTERISTICS

($T_a = 25^\circ\text{C}$, $V_{CC} = 13.2\text{V}$, $R_L = 4\Omega$, $R_o = 600\Omega$, $f = 1\text{KHz}$, unless otherwise specified)

Characteristic	Symbol	Test Conditions	Min	Typ	Max	Unit
Quiescent Circuit Current	I_{CC}	$V_i = 0$		80	145	mA
Output Power	P_o	THD = 10%	5	5.8		W
Total Harmonic Distortion	THD	$P_o = 1\text{W}$		0.06	0.3	%
Voltage Gain	A_V	$V_o = 0\text{dBm}$	50	52	54	dB
Channel Balance	CB	$V_o = 0\text{dBm}$	-1	0	1	dB
Output Noise Voltage	V_{NO}	$R_o = 10\text{K}\Omega$, BW(-3dB) = 20Hz ~ 20KHz		0.7	1.5	mV
Ripple Rejection Ratio	RR	$f = 120\text{Hz}$, $V_i = 0\text{dBm}$	40	52		dB
Cross Talk	CT	$V_o = 0\text{dBm}$		57		dB
Input Resistance	R_i	$f = 1\text{KHz}$		33		$\text{K}\Omega$



KA2211

LINEAR INTEGRATED CIRCUIT

TEST AND APPLICATION CIRCUIT

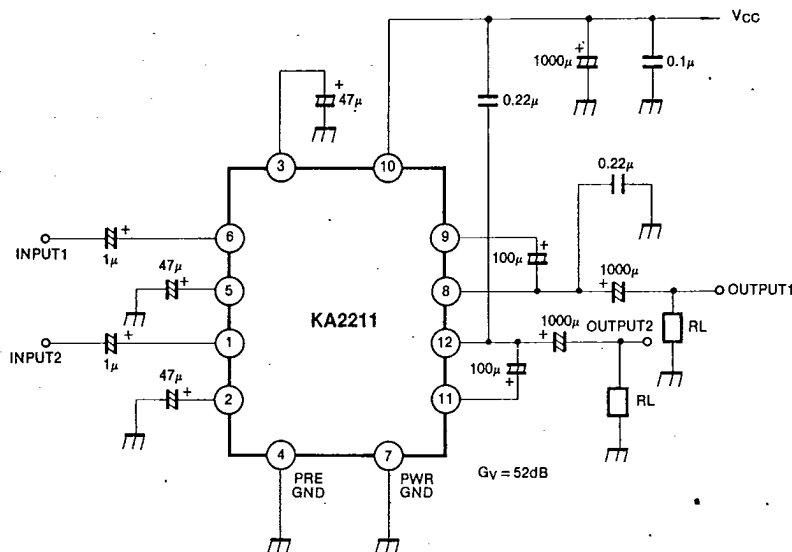
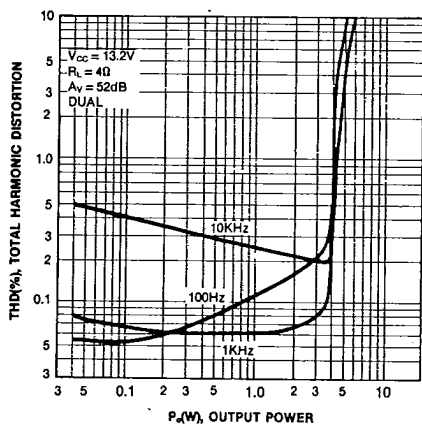
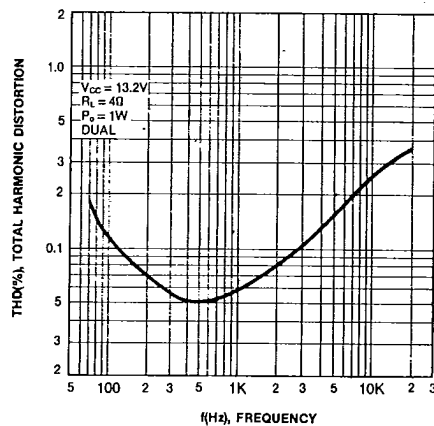

Fig. 2

TOTAL HARMONIC DISTORTION-OUTPUT POWER



TOTAL HARMONIC DISTORTION-FREQUENCY



T-74-05-01

KA2211

LINEAR INTEGRATED CIRCUIT

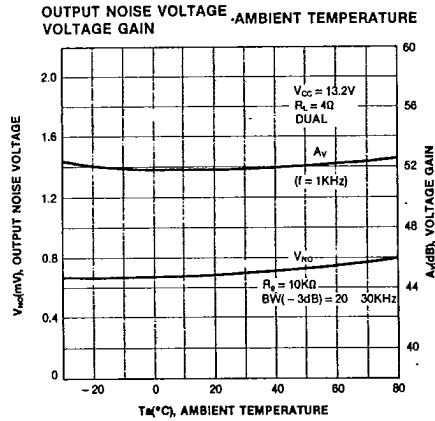
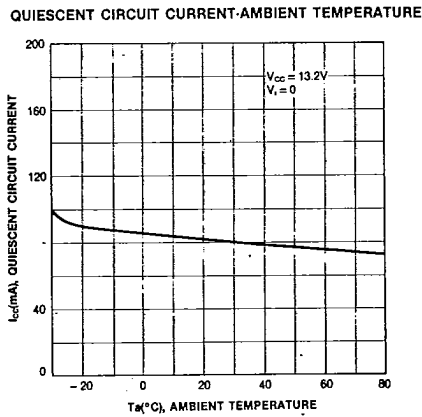
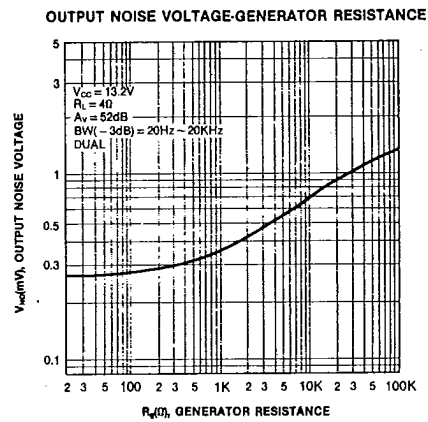
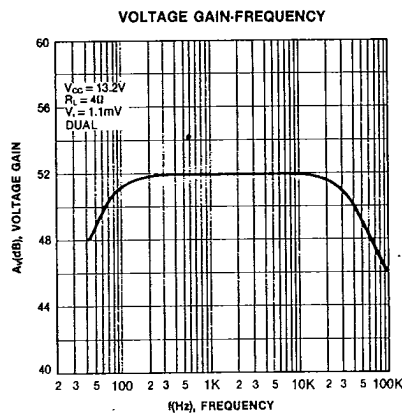
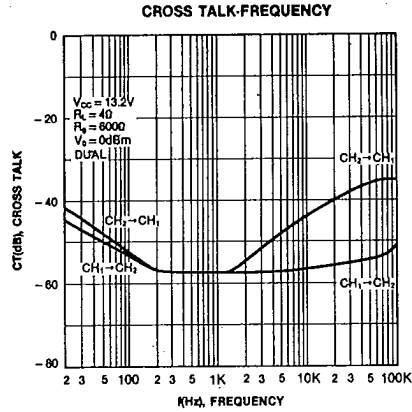
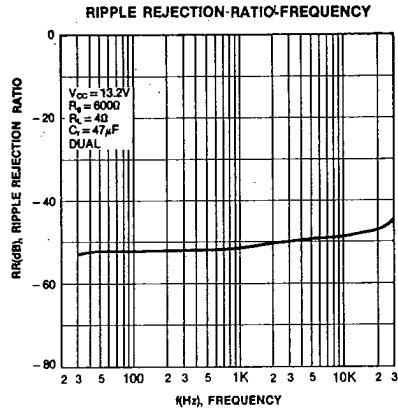

T-74-05-01

KA2211

LINEAR INTEGRATED CIRCUIT

QUIESCENT CIRCUIT CURRENT-SUPPLY VOLTAGE

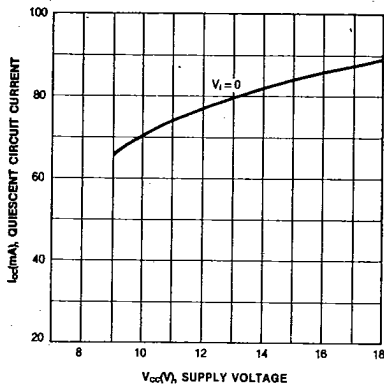

POWER DISSIPATION-SUPPLY VOLTAGE

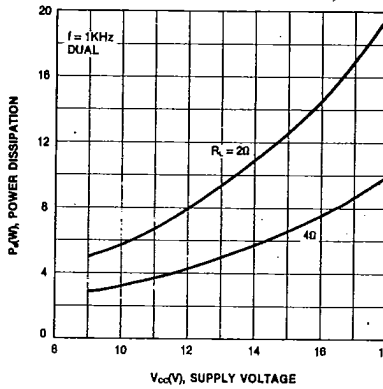

POWER DISSIPATION-OUTPUT POWER

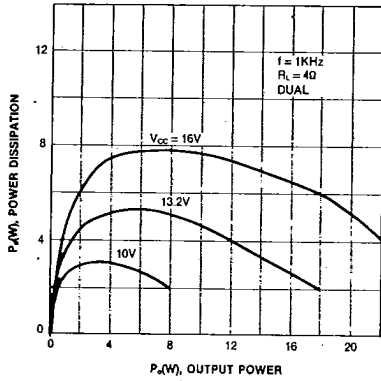

POWER DISSIPATION-OUTPUT POWER

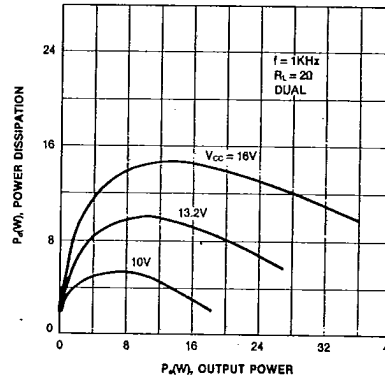

OUTPUT POWER-SUPPLY VOLTAGE

