

DUAL PRE-POWER AMPLIFIER WITH DC VOLUME CONTROL

The KA22134 is a monolithic integrated circuit designed for use in low voltage and low power applications. It has all functions including a dual audio pre-power amplifier, DC volume control and headphone drive circuits.

It is suitable for portable tape recorders or headphone cassette recorders.

FEATURES

- Built-in DC volume control circuit.
- Wide operation supply voltage: $V_{CC} = 1.8 \sim 6V$
- Only a few components to build headphone cassette tape recorders.
- Built-in ripple filter.

BLOCK DIAGRAM

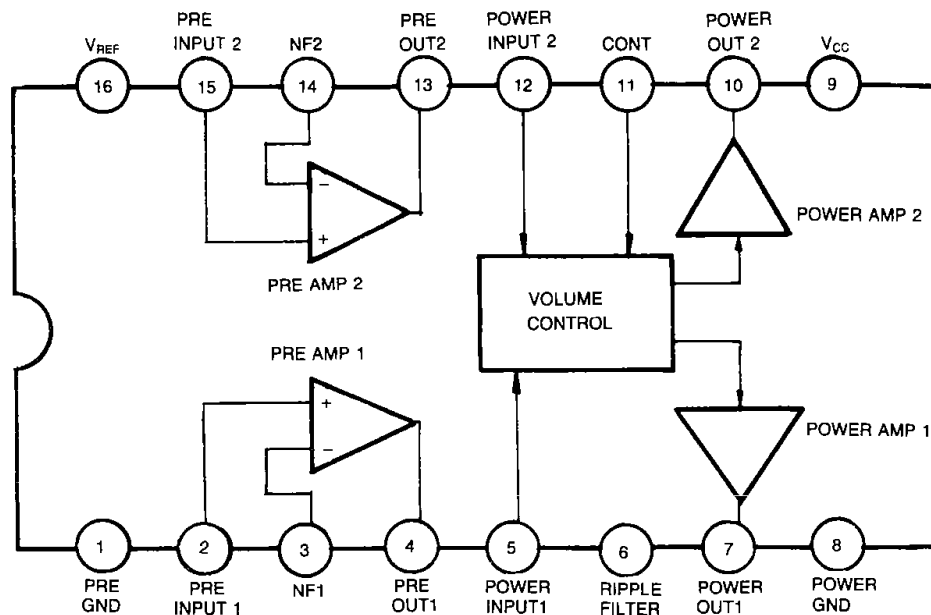
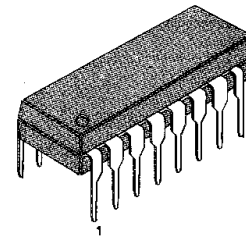

Fig. 1

16 DIP



ORDERING INFORMATION

Device	Package	Operating Temperature
KA22134	16 DIP	-20°C ~ +75°C

ABSOLUTE MAXIMUM RATINGS ($T_a = 25^\circ\text{C}$)

Characteristic	Symbol	Value	Unit
Supply Voltage	V_{CC}	7	V
Power Dissipation	P_D	75	mW
Operating Temperature	T_{OPR}	-20 ~ +75	$^\circ\text{C}$
Storage Temperature	T_{STG}	-40 ~ +125	$^\circ\text{C}$

ELECTRICAL CHARACTERISTICS($V_{CC} = 3\text{V}$, $T_a = 25^\circ\text{C}$)

Characteristic	Symbol	Test Conditions	Min	Typ	Max	Unit
Quiescent Circuit Current	I_{CCQ1}	$V_i = 0$, $V_{OL} = \text{MIN}$		9	13	mA
	I_{CCQ2}	$V_i = 0$, $V_{OL} = \text{MAX}$		11.0		mA
Cross Talk	CT	$R_G = 2.2\text{K}\Omega$, $V_o = -10\text{dBm}$	34	40		dB

PRE-AMPLIFIER SECTION($V_{CC} = 3\text{V}$, $T_a = 25^\circ\text{C}$, $f = 1\text{KHz}$, $R_{L1} = 10\text{K}\Omega$, unless otherwise specified)

Characteristic	Symbol	Test Conditions	Min	Typ	Max	Unit
Open Loop Voltage Gain	G_{VO}	$V_i = 0.2\text{mV}$	55	62		dB
Closed Loop Voltage Gain	G_{VC1}	$V_o = -10\text{dBm}$, NAB 1KHz		33		dB
Output Voltage	V_o	THD = 1%	600	720		mV
Total Harmonic Distortion	THD ₁	$V_o = -10\text{dBm}$		0.04	0.1	%
Ripple Rejection Ratio	RR ₁	$R_G = 2.2\text{K}\Omega$ $V_R = -20\text{dBm}$, $f_R = 100\text{Hz}$		46		dB
Equivalent Input Noise Voltage	V_{NI}	$R_G = 2.2\text{K}\Omega$, BW = 30 ~ 20KHz Gain for NAB 1KHz		1.2	2.0	μV

POWER AMPLIFIER SECTION($V_{CC} = 3\text{V}$, $T_a = 25^\circ\text{C}$, $f = 1\text{KHz}$, $R_{L2} = 32\Omega$, unless otherwise specified)

Characteristic	Symbol	Test Conditions	Min	Typ	Max	Unit
Output Power	P_{O1}	THD ₂ = 10%	20	27		mW
	P_{O2}	THD ₂ = 10%, $R_L = 16\Omega$		39		mW
Total Harmonic Distortion	THD ₂	$P_o = 10\text{mW}$, Volume: 100%		0.5	1.2	%
	THD ₃	$P_o = 10\text{mW}$, Volume: 50%		0.3		%
Closed Loop Voltage Gain	G_{VC2}	$V_o = -10\text{dBm}$, Volume: 100%	28	30	32	dB
	G_{VC3}	$V_o = -10\text{dBm}$		15		dB
Channel Balance	CB	$V_o = -10\text{dBm}$	-1.5	0	-1.5	dB
Volume Rejection Ratio	VOL _{REJ}	$V_o = -10\text{dBm}$, Volume: 100% to 0%	66	72		dB
Output Noise Voltage	V_{NO}	BW = 30 ~ 20KHz, $R_G = 600\Omega$		250	320	μV
Ripple Rejection Ratio	RR ₂	$R_G = 600\Omega$, $f_R = 100\text{Hz}$ $V_R = -20\text{dBm}$		46		dB

TEST CIRCUIT

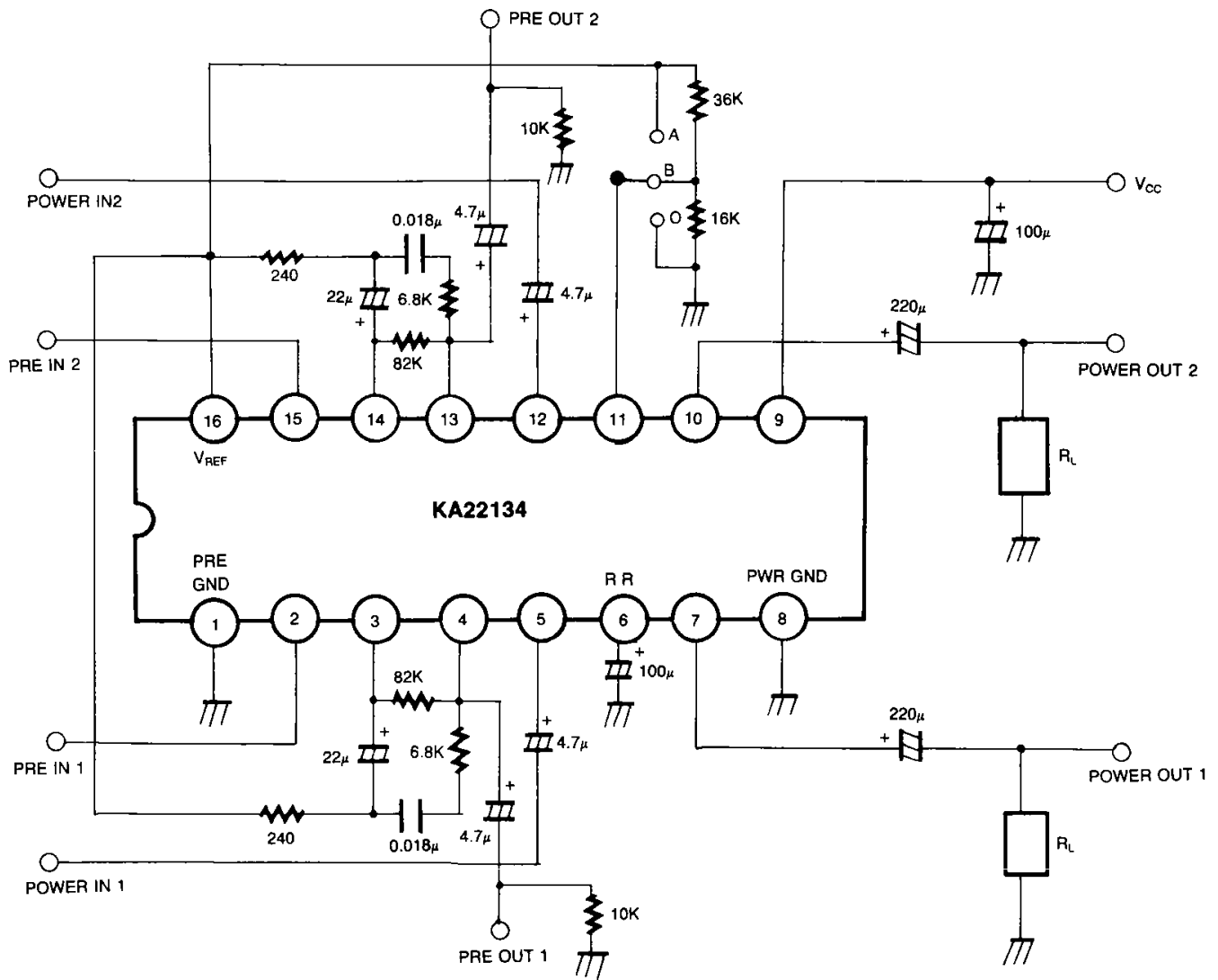

Fig. 2

APPLICATION CIRCUIT

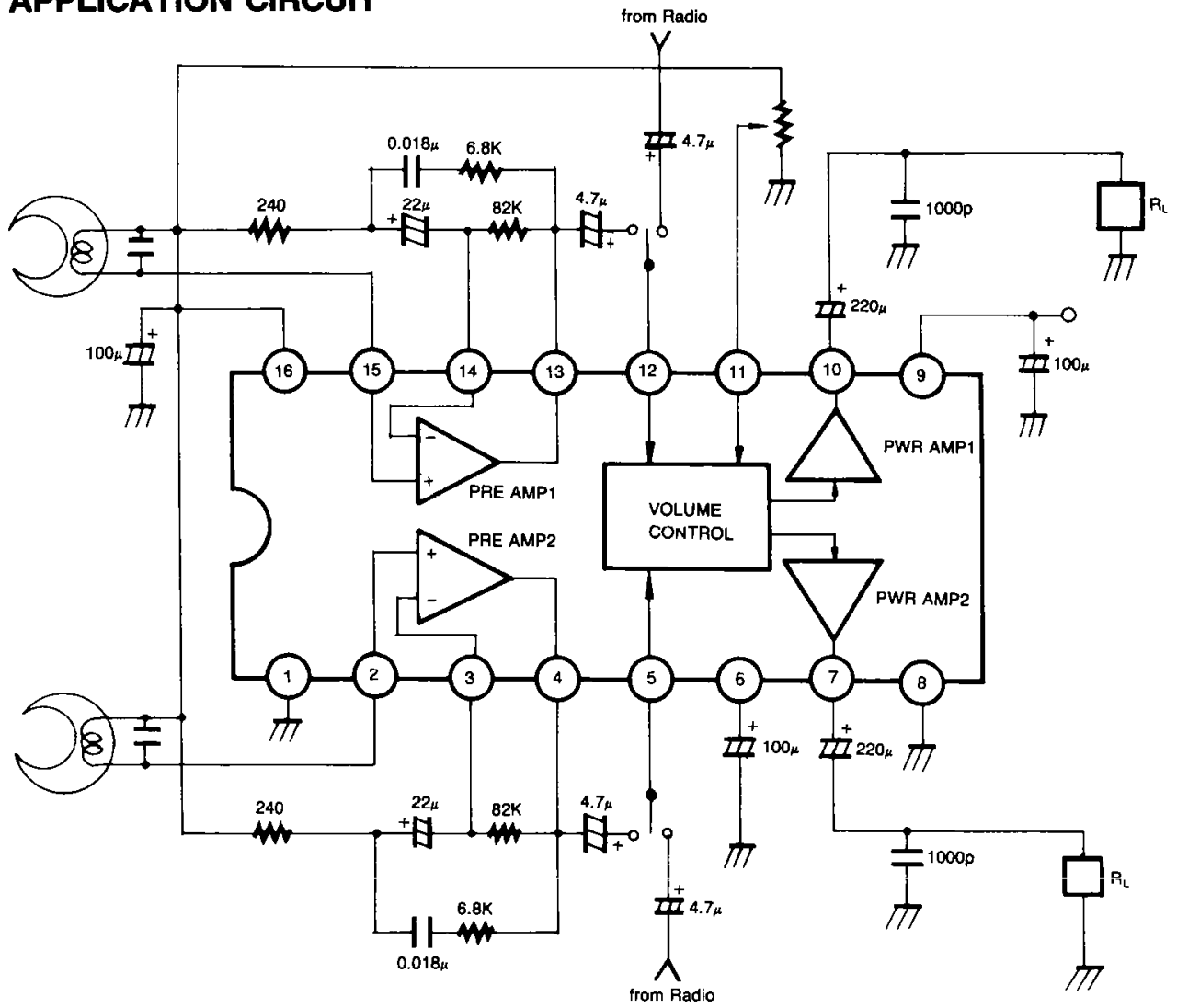

Fig. 3