

INTRODUCTION

The KA22426 is a monolithic integrated circuit designed for radio-cassette tape recorders, clock radios and headphone radios.

FUNCTIONS

- AM/FM RF AMP
- AM AGC Control
- Audio Power AMP
- DC Volume
- FM Quadrature DET
- Local OSC
- FM AFC Control
- Tuning Indicator
- AM/FM IF AMP
- AM DET

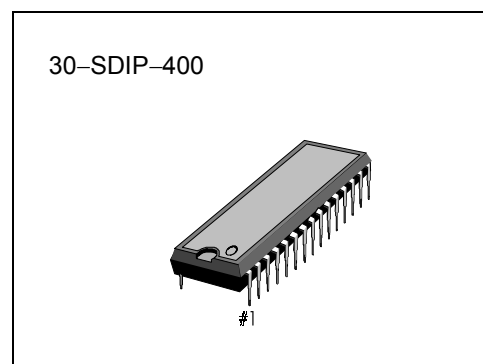

FEATURES

- Built-in AM/FM Switching Circuit
- Wide operating supply voltage: $V_{CC} = 2V \sim 8.5V$
- Low current consumption ($V_{CC} = 3V$)
 - FM: $I_{CCQ} = 5.3mA$ (Typ)
 - AM: $I_{CCQ} = 3.4mA$ (Typ)
- High Power Audio Amplifier: 0.5W (typ) at $V_{CC} = 6V$, $R_L = 8$, THD = 10%

ORDERING INFORMATION

Device	Package	Operating Temperature
KA22426	30-SDIP-400	-20°C ~ +70°C

BLOCK DIAGRAM

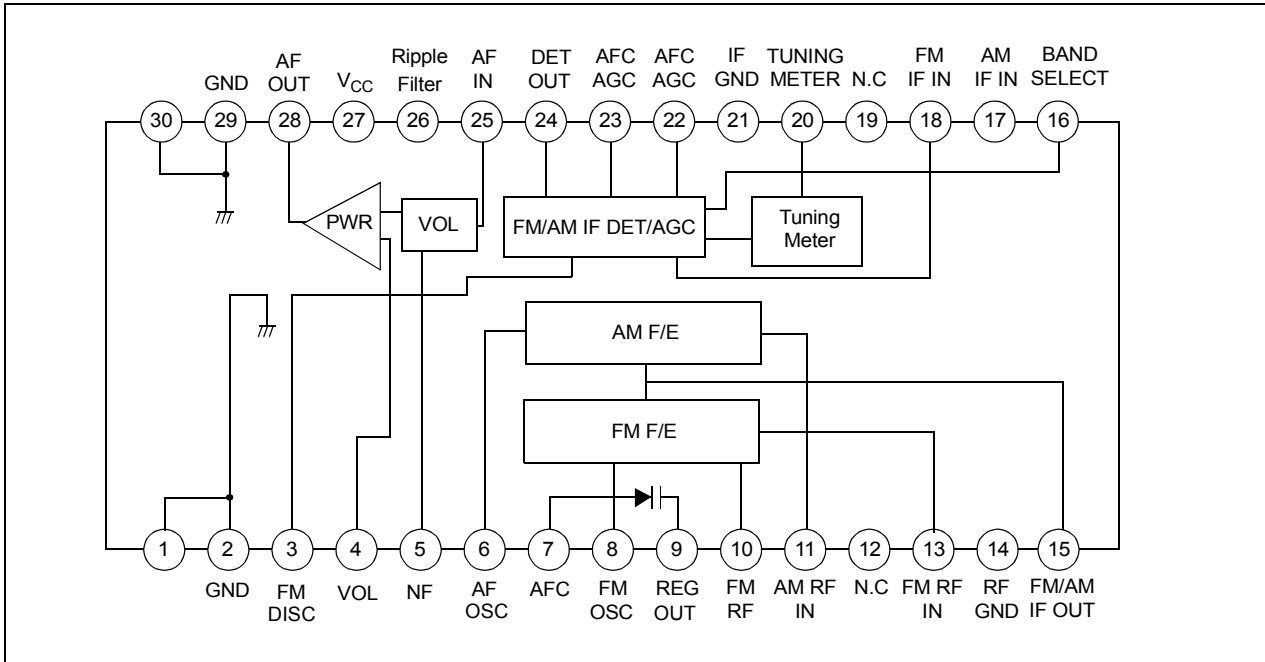

Figure 1.

ABSOLUTE MAXIMUM RATINGS (Ta = 25°C)

Characteristic	Symbol	Value	Unit
Supply Voltage	V _{CC}	9	V
Power Dissipation	P _D	1000	mW
Operating Temperature	T _{OPR}	-20 ~ +70	°C
Storage Temperature	T _{STG}	-40 ~ +125	°C

ELECTRICAL CHARACTERISTICS

(V_{CC} = 6V, T_a = 25°C, FM; Δf = 22.5kHz, f_m = 1kHz, AM; 30% Mod, unless otherwise specified)

	Characteristic	Symbol	Test Condition	Min.	Typ.	Max.	Unit
FM	Quiescent Circuit Current	I _{CCQ}	V _I = 0	–	7.0	14.0	mA
	F/E Voltage Gain	G _{V1V}	V _I (1) = 40dBμ, f _c = 100MHz, Δf = 0	32	39	46	dB
	Detect Output Gain	V _O (1)	V _I (3) = 90dBμ, f _i = 10.7MHz	–26	–20	–14	dBm
	IF-3 dB Sensitivity	V _{I(LIM)}	Vo(VI3) = 90dBμ, -3dB, f _i = 10.7MHz	–	24	32	dBμ
	Total Harmonic Distortion	THD ₁	V _I (3) = 90dBμ, f _i = 10.7MHz(Δf = 75kHz)	–	0.3	2.0	%
	Meter Drive Current	I _M (1)	V _I (3) = 60dBμ, f _i = 10.7MHz	1.8	3.5	7.0	mA
AM	Quiescent Circuit Current	I _{CCQ(2)}	V _I = 0	–	3.5	10.0	mA
	F/E Voltage Gain	G _{V(2)}	V _I (2) = 60dBμ, f _c = 1660kHz, m=0%	15	22	29	dB
	IF Voltage Gain	G _{V(3)}	Vo(3) = -34dBm, f _i = 455kHz	14	20	27	dBμ
	AM Detect Output Voltage	V _O (2)	V _I (3) = 85dBμ, f _i = 455kHz	–26	–20	–14	dBm
	Total Harmonic Distortion	THD ₂	V _I (2) = 95dBμ, f _c = 1660kHz, V _{CC} = 7.8V	–	0.6	2.0	%
	Meter Drive Current	I _M (2)	V _I (3) = 85dBμ, f _i = 455kHz	1.3	3.0	7.0	mA
AF	Closed Loop Voltage Gain	G _{V(4)}	Vo(4) = 0dBm, f = 1kHz	27	31.5	36	dB
	Total Harmonic Distortion	THD ₃	P _o = 50mW, f = 1kHz	–	0.3	2.5	%
	Output Power	P _O	R _L = 8Ω, THD = 10%, f = 1kHz	0.4	0.5	–	W

APPLICATION CIRCUIT

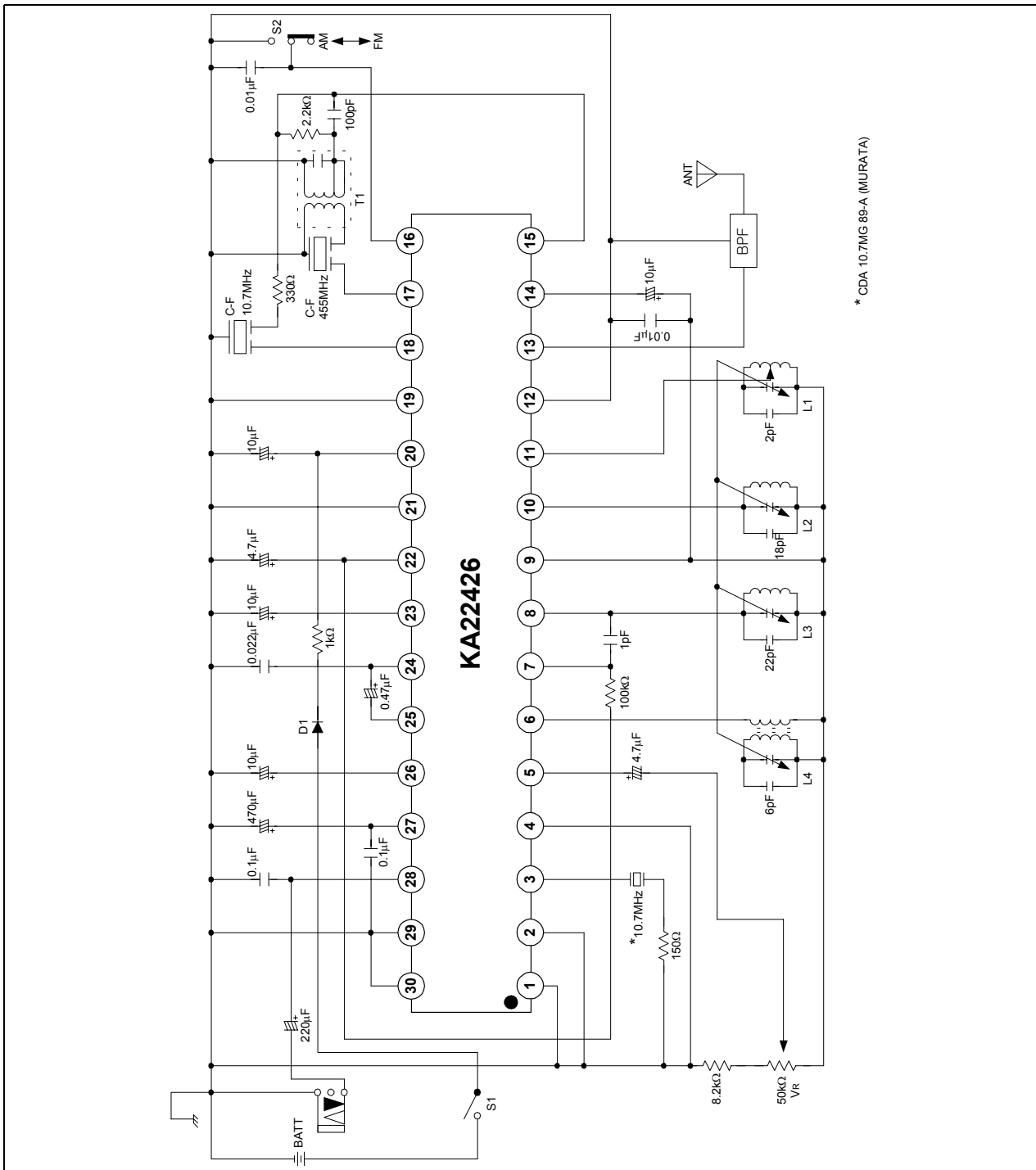

Figure 2.