

INTROCUCTION

The KA22425D is a monolithic integrated circuit designed for radio cassette tape recorders, clock radios and headphone radios.

FUNCTIONS

- AM/FM RF AMP
- AM AGO Control
- Audio Power AMP
- DC Volume
- FM Quadrature DET
- AUDIO MUTE
- Local OSC
- FM AFO Control
- Tuning Indicator
- AM/FM IF AMP
- AM DET

FEATURES

- Built-in AM/FM Switching Circuit
- Wide operating supply voltage: $V_{CC} = 2V \sim 7.5V$
- Low current consumption ($V_{CC} = 3V$)
 - FM: $I_{CCQ} = 5.3mA$ (Typ)
 - AM: $I_{CCQ} = 3.4mA$ (Typ)
- High power audio amplifier: $0.5W$ (Typ) at $V_{CC} = 6V$,
- $R_L = 8\Omega$, THD = 10 %

ORDERING INFORMATION

Device	Package	Operating Temperature
KA22425D	28-SOP-375	-20°C ~ +70°C

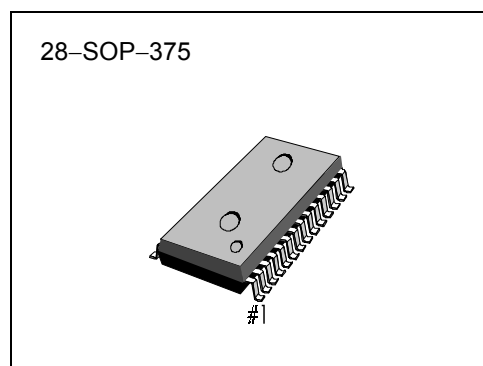

BLOCK DIAGRAM

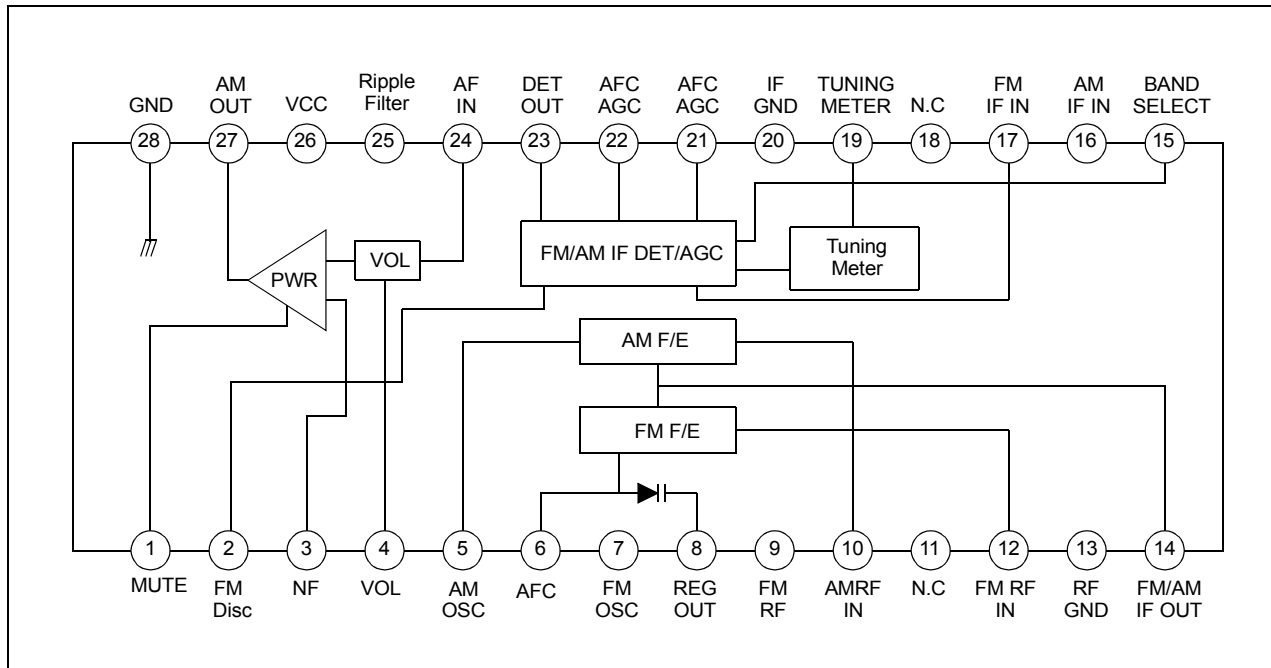

Figure 1.

ABSOLUTE MAXIMUM RATINGS ($T_a = 25^\circ\text{C}$)

Characteristic	Symbol	Value	Unit
Supply Voltage	V_{CC}	9	V
Power Dissipation	P_D	1000	mW
Operating Temperature	T_{OPR}	-20 ~ +70	$^\circ\text{C}$
Storage Temperature	T_{STG}	-40 ~ +125	$^\circ\text{C}$

ELECTRICAL CHARACTERISTICS

(V_{CC} = 6V, Ta = 25°C, FM; Δf = 22.5kHz, fm = 1kHz, AM; 30% Mod, unless otherwise specified)

	Characteristic	Symbol	Test Conditions	Min.	Typ.	Max.	Unit
FM	Quiescent Circuit Current	I _{CCQ(1)}	V _I = 0	–	7.0	14.0	mA
	F/E Voltage Gain	G _{V(1)}	V _{I(1)} = 40dBμ, f _c = 100MHz, f = 0	32	39	46	dB
	Detect Output Gain	V _{O(1)}	V _{I(3)} = 90dBμ, f _i = 10.7MHz	–26	–20	–14	dBm
	IF-3 dB Sensitivity	V _{I(LIM)}	V _{O(VI3)} = 90dBμ –3dB, f _i = 10.7MHz	–	24	32	dBμ
	Total Harmonic Distortion	THD ₁	V _{I(3)} = 90dBμ, f _i = 10.7MHz(Δf = 75kHz)	–	0.3	2.0	%
	Meter Drive Current	I _{M(1)}	V _{I(3)} = 60dBμ, f _i = 10.7MHz	1.8	3.5	7.0	mA
AM	Quiescent Circuit Current	I _{CCQ(2)}	V _I = 0	–	3.5	10.0	mA
	F/E Voltage Gain	G _{V(2)}	V _{I(2)} = 60dBμ, f _c = 1660kHz, m = 0%	15	22	29	dB
	IF Voltage Gain	G _{V(3)}	V _{O(3)} = –34dBm, f _i = 455kHz	14	20	27	dBμ
	AM Detect Output Voltage	V _{O(2)}	V _{I(3)} = 85dBμ, f _i = 455kHz	–26	–20	–14	dBm
	Total Harmonic Distortion	THD ₂	V _{I(2)} = 95dBμ, f _c = 1660kHz, V _{CC} =7.8V	–	0.6	2.0	%
	Meter Drive Current	I _{M(2)}	V _{I(3)} = 85dBμ, f _i = 455kHz	1.3	3.0	7.0	mA
AF	Closed Loop Voltage Gain	G _{V(4)}	V _{O(4)} = 0dBm, f = 1kHz	27	31.5	36	dB
	Total Harmonic Distortion	THD ₃	P _O = 50mW, f = 1kHz	–	0.3	2.5	%
	Output Power	P _O	R _L = 8Ω, THD = 10%, f = 1kHz	0.4	0.5	–	W
	Mute Level	M _L	P _O = mW, V _{i(4)} = 30dBm 1kHz, V ₁₍₃₎ = FF	8	15	22	dB

APPLICATION CIRCUIT

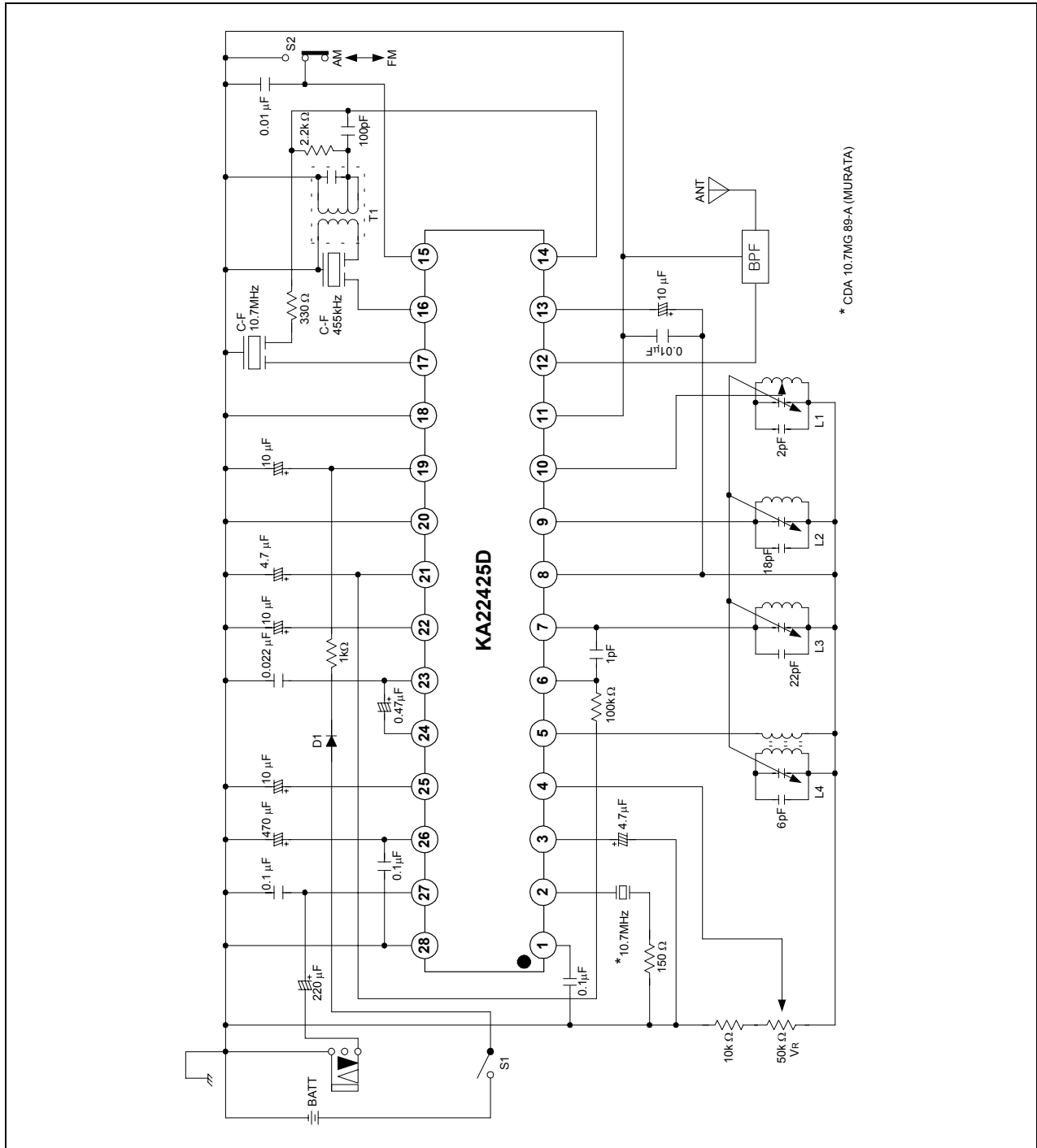

Figure 2.