

HMC542ALP4 / 542ALP4E

0.5 dB LSB GaAs MMIC 6-BIT DIGITAL SERIAL CONTROL ATTENUATOR, DC - 3 GHz

Typical Applications

The HMC542ALP4(E) is ideal for:

- Cellular/PCS/3G Infrastructure
- ISM, MMDS, WLAN, WiMAX, & WiBro
- Microwave Radio & VSAT
- Test Equipment and Sensors

Features

- 0.5 dB LSB Steps to 31.5 dB
- TTL/CMOS Compatible Serial Data Interface
- SPI Compatible Serial Output
- ± 0.25 dB Typical Step Error
- Single +5V Supply
- 24 Lead 4x4mm QFN Package: 16mm²

Functional Diagram

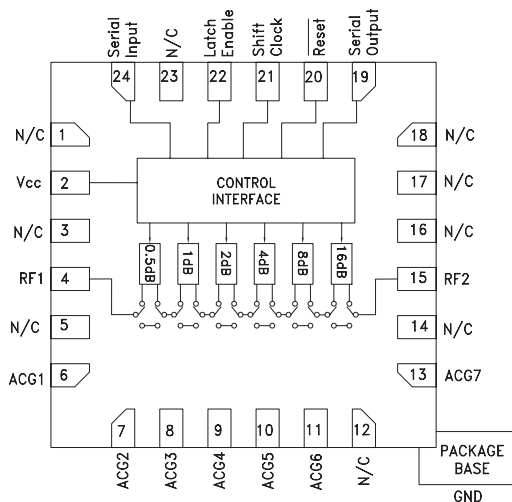

General Description

The HMC542ALP4(E) is a broadband 6-bit GaAs IC digital attenuator with a CMOS compatible serial to parallel driver in low cost leadless surface mount package. This serial control digital attenuator incorporates off chip AC ground capacitors for near DC operation, making it suitable for a wide variety of RF and IF applications. Covering DC to 3 GHz, the insertion loss is 1.5 dB and the attenuator bit values are 0.5 (LSB), 1, 2, 4, 8, and 16 dB for a total attenuation of 31.5 dB. Attenuation accuracy is excellent at ±0.25 dB typical step error with an IIP3 of +45 dBm. Six bit serial control words are used to select each attenuation state. A single V_{dd} bias of +5V is required.

Electrical Specifications, T_A = +25° C, with V_{cc} = +5V

Parameter	Frequency (GHz)	Min.	Typ.	Max.	Units
Insertion Loss	DC - 1.5 GHz		1.2	1.5	dB
	1.5 - 3.0 GHz		1.5	1.8	dB
Attenuation Range	DC - 3 GHz		31.5		dB
Return Loss (RF1 & RF2, All Atten. States)	DC - 3 GHz		17		dB
Attenuation Accuracy: (Referenced to Insertion Loss)					
All Attenuation States	DC - 1.0 GHz	± (0.20 + 3% of Atten. Setting) Max.			dB
0.5 - 3.5 dB States	1.0 - 2.2 GHz	± (0.25 + 3% of Atten. Setting) Max.			dB
4.0 - 31.5 dB States	1.0 - 2.2 GHz	± (0.15 + 4% of Atten. Setting) Max.			dB
All Attenuation States	2.2 - 3.0 GHz	± (0.30 + 3% of Atten. Setting) Max.			dB
Input Power for 0.1 dB Compression	0.1 - 3.0 GHz		20		dBm
Input Third Order Intercept Point (Two-Tone Input Power= 0 dBm Each Tone)	0.1 - 1.5 GHz		35		dBm
	1.5 - 3.0 GHz		45		dBm
Switching Characteristics					
tRISE, tFALL (10/90% RF)	DC - 3 GHz		800		ns
tON, tOFF (50% CTL to 10/90% RF)			900		ns

Insertion Loss

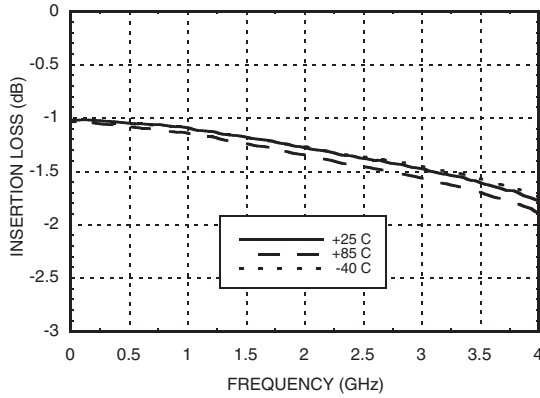

Return Loss RF1, RF2 (Only Major States are Shown)

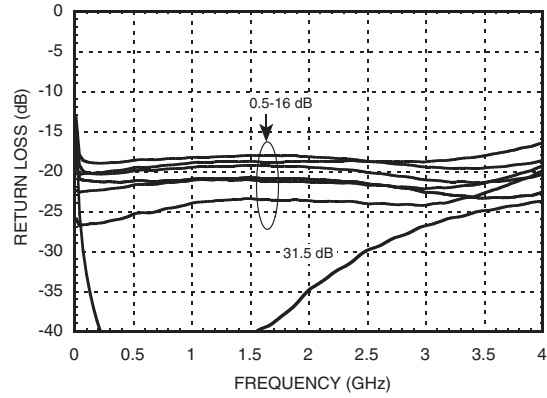

Normalized Attenuation

(Only Major States are Shown)

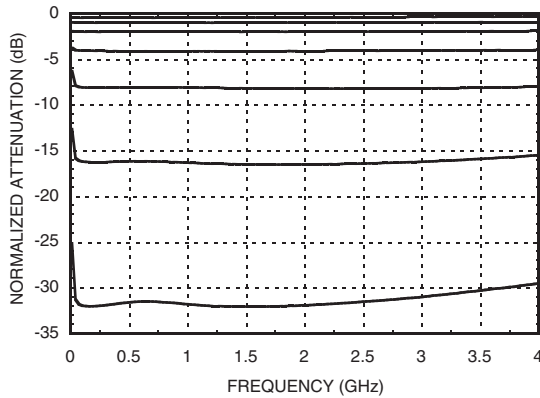

Bit Error vs. Attenuation State

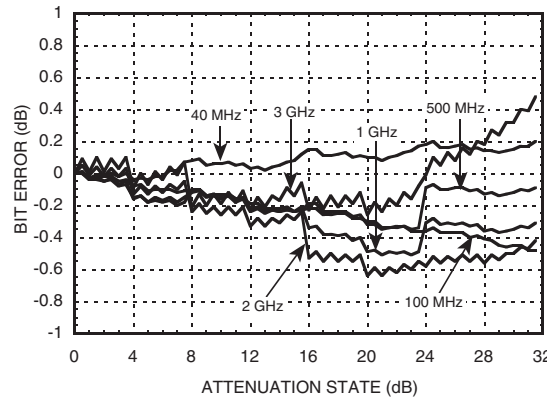

Bit Error vs. Frequency

(Only Major States are Shown)

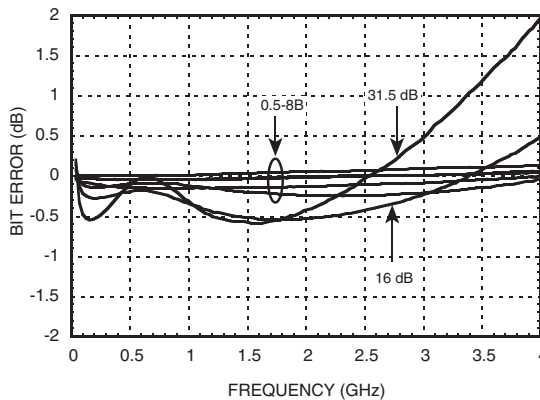

Relative Phase vs. Frequency

(Only Major States are Shown)

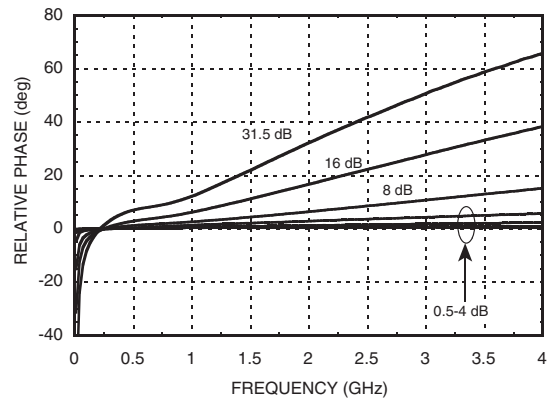

Worst Case Step Error Between Successive Attenuation States

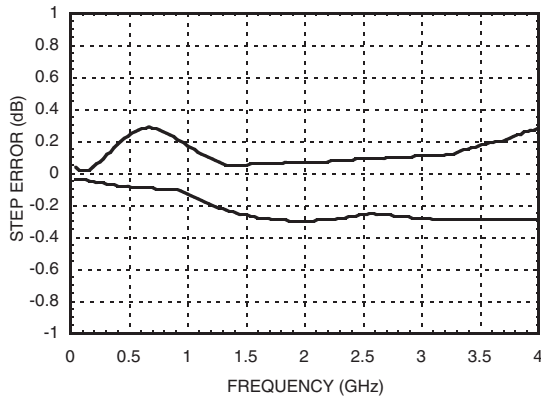

Digital Control Voltages

State	Vcc = +5V
Low	0 to 1.3V
High	3 to 5V

Serial Input Truth Table

Latch Enable	Shift Clock	Reset	Function
X	X	L	Shift register cleared
X	↑	H	Shift register clocked
↑	X	H	Contents of shift register transferred to Digital Attenuator

Timing

Parameter	Symbol	Vcc = +5V		Units
		Min.	Max.	
Serial Input Setup Time	ts	20	-	ns
Hold time from Serial Input to Shift Clock	th	0	-	ns
Setup time from Shift Clock to Latch Enable	tlsup	40	-	ns
Latch Enable Window, Latch Enable to C0.5 through C8	tpd	-	30	ns
Setup time from Reset to Shift Clock	-	20	-	ns
Clock Frequency (1/tclk)	fclk	-	30	MHz

Truth Table

Control Voltage Input						
C16	C8	C4	C2	C1	C0.5	
High	High	High	High	High	High	Reference I.L.
High	High	High	High	High	Low	0.5 dB
High	High	High	High	Low	High	1 dB
High	High	High	Low	High	High	2 dB
High	High	Low	High	High	High	4 dB
High	Low	High	High	High	High	8 dB
Low	High	High	High	High	High	16 dB
Low	Low	Low	Low	Low	Low	31.5 dB

Any combination of the above states will provide an attenuation approximately equal to the sum of the bits selected.

Timing Diagram

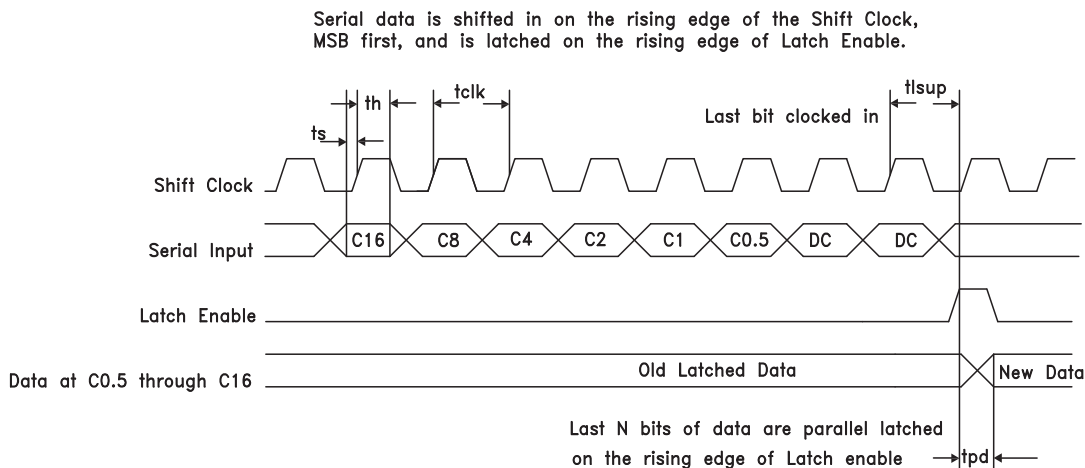

Logic / Functional Diagram

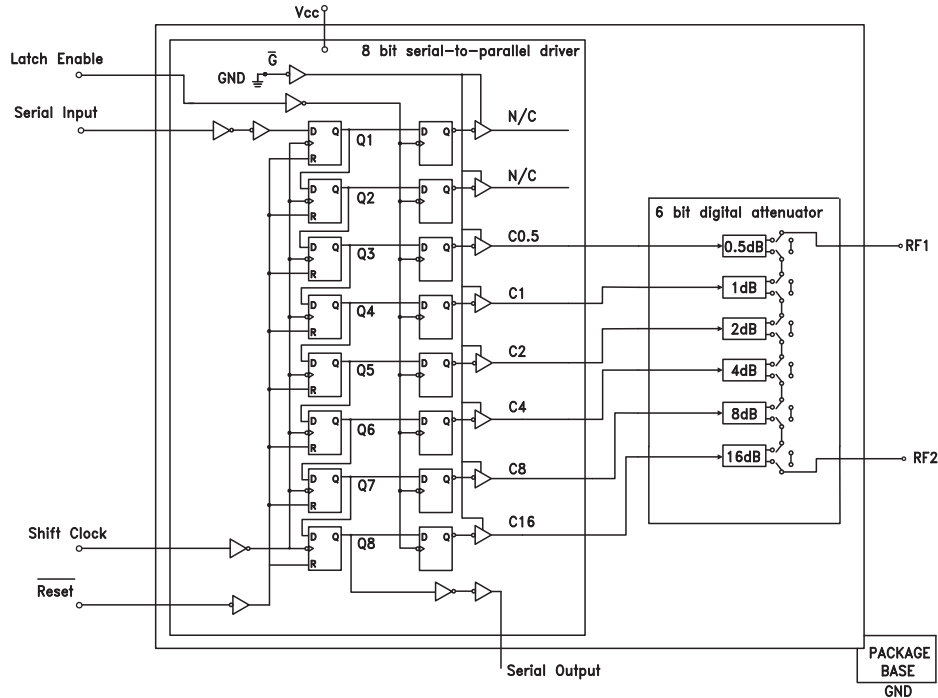

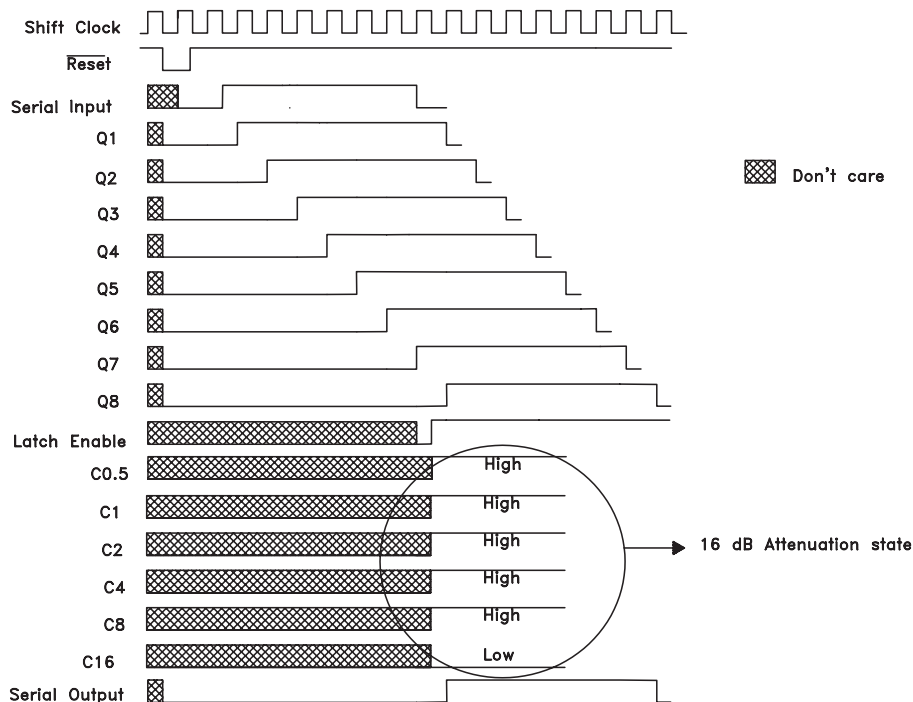

Programming Example to Select 16 dB Attenuation State



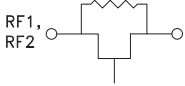
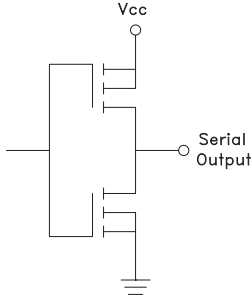
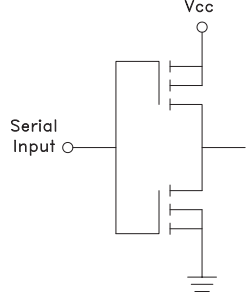

0.5 dB LSB GaAs MMIC 6-BIT DIGITAL SERIAL CONTROL ATTENUATOR, DC - 3 GHz

Pin Descriptions

Pin Number	Function	Description	Interface Schematic
1, 3, 5, 14, 16-18, 23	N/C	These pins are not connected internally. However, all data shown herein was measured with these pins connected to RF/DC Ground.	
2	Vcc	Supply Voltage.	
4, 15	RF1, RF2	This pin is DC coupled and matched to 50 Ohms. Blocking capacitors are required. Select value based on lowest frequency of operation.	
6 - 11, 13	ACG1 - ACG7	External capacitor to ground is required. Select value for lowest frequency of operation. Place capacitor as close to pins as possible.	
12	N/C	This pin is not connected internally and any connection made to it externally will have no effect on product performance.	
19	Serial Output	Serial data output. Serial input data delayed by 8 clock cycles.	
20	Reset	See truth table, control voltage table and timing diagram.	
21	Shift Clock		
22	Latch Enable		
24	Serial Input		
	GND	Package bottom has an exposed metal paddle that must be connected to RF/DC Ground.	



0.5 dB LSB GaAs MMIC 6-BIT DIGITAL SERIAL CONTROL ATTENUATOR, DC - 3 GHz

Application Circuit

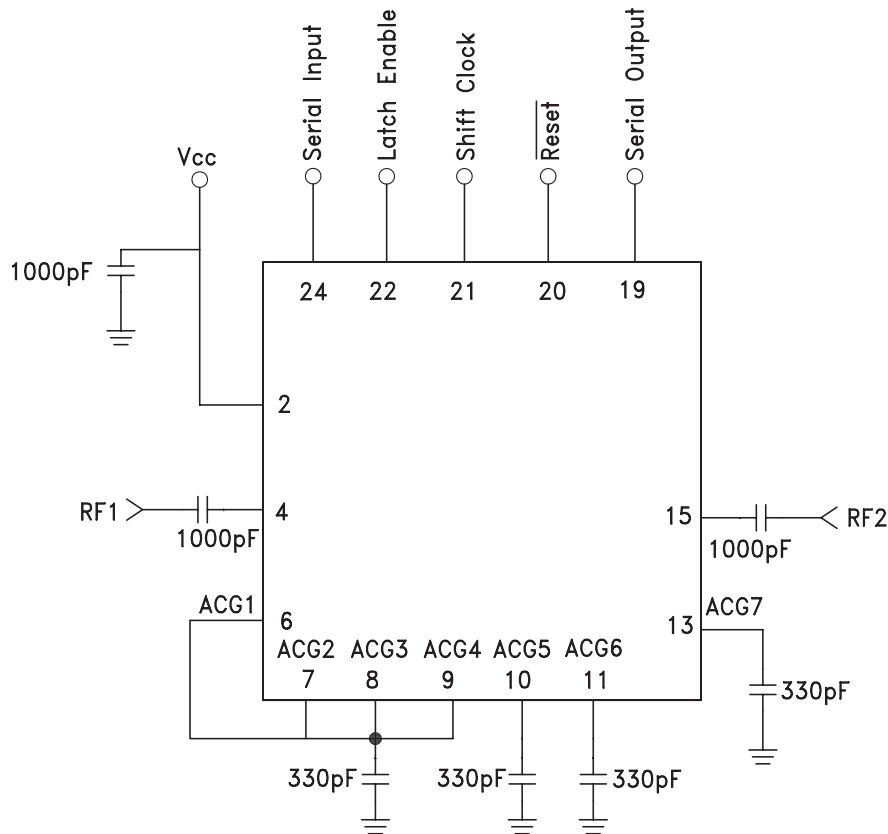

Absolute Maximum Ratings

RF Input Power (DC - 3 GHz)	+27 dBm (T = +85 °C)
Digital Inputs (Reset, Shift Clock, Latch Enable & Serial Input)	-0.5 to (Vcc +0.5) V
Bias Voltage (Vcc)	+5.6 V
Channel Temperature	150 °C
Continuous Pdiss (T = 85 °C) (derate 7.7 mW/°C above 85 °C)	0.5 W
Thermal Resistance	130 °C/W
Storage Temperature	-65 to +150 °C
Operating Temperature	-40 to +85 °C

Bias Voltage

Vcc (V)	Idd (Typ.) (mA)
+4.5	4.7
+5.0	5.0
+5.5	5.3



ELECTROSTATIC SENSITIVE DEVICE
OBSERVE HANDLING PRECAUTIONS

Outline Drawing

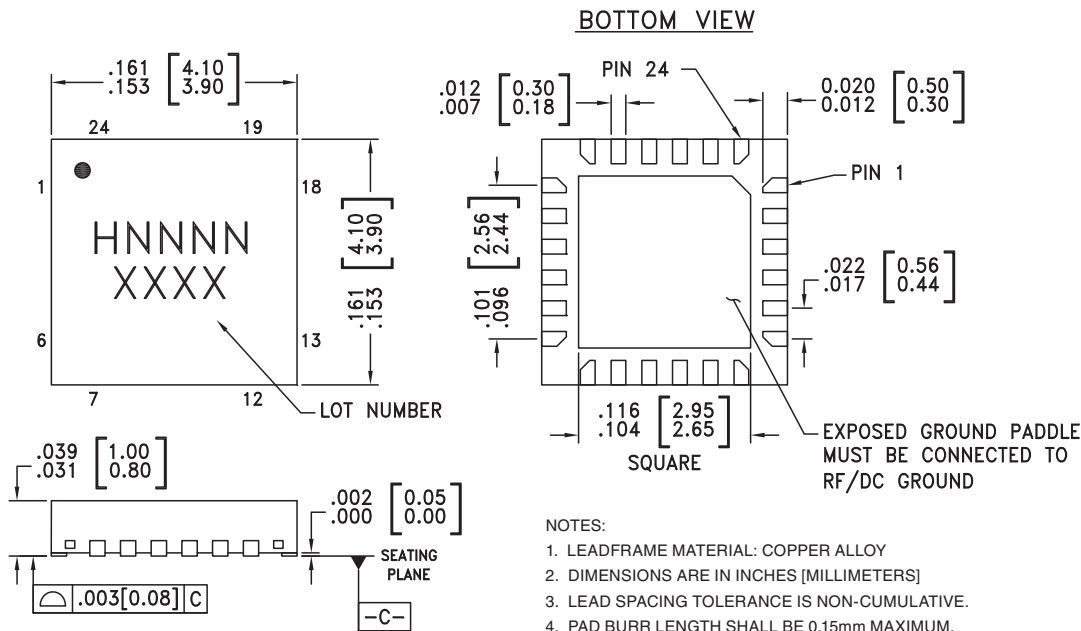

NOTES:

- LEADFRAME MATERIAL: COPPER ALLOY
- DIMENSIONS ARE IN INCHES [MILLIMETERS]
- LEAD SPACING TOLERANCE IS NON-CUMULATIVE.
- PAD BURR LENGTH SHALL BE 0.15mm MAXIMUM.
PAD BURR HEIGHT SHALL BE 0.05mm MAXIMUM.
- PACKAGE WARP SHALL NOT EXCEED 0.05mm.
- ALL GROUND LEADS AND GROUND PADDLE MUST BE SOLDERED TO PCB RF GROUND.
- REFER TO HITTITE APPLICATION NOTE FOR SUGGESTED LAND PATTERN.

Package Information

Part Number	Package Body Material	Lead Finish	MSL Rating	Package Marking ^[3]
HMC542ALP4	Low Stress Injection Molded Plastic	Sn/Pb Solder	MSL1 ^[1]	H542A XXXX
HMC542ALP4E	RoHS-compliant Low Stress Injection Molded Plastic	100% matte Sn	MSL1 ^[2]	H542A XXXX

[1] Max peak reflow temperature of 235 °C

[2] Max peak reflow temperature of 260 °C

[3] 4-Digit lot number XXXX

Evaluation PCB

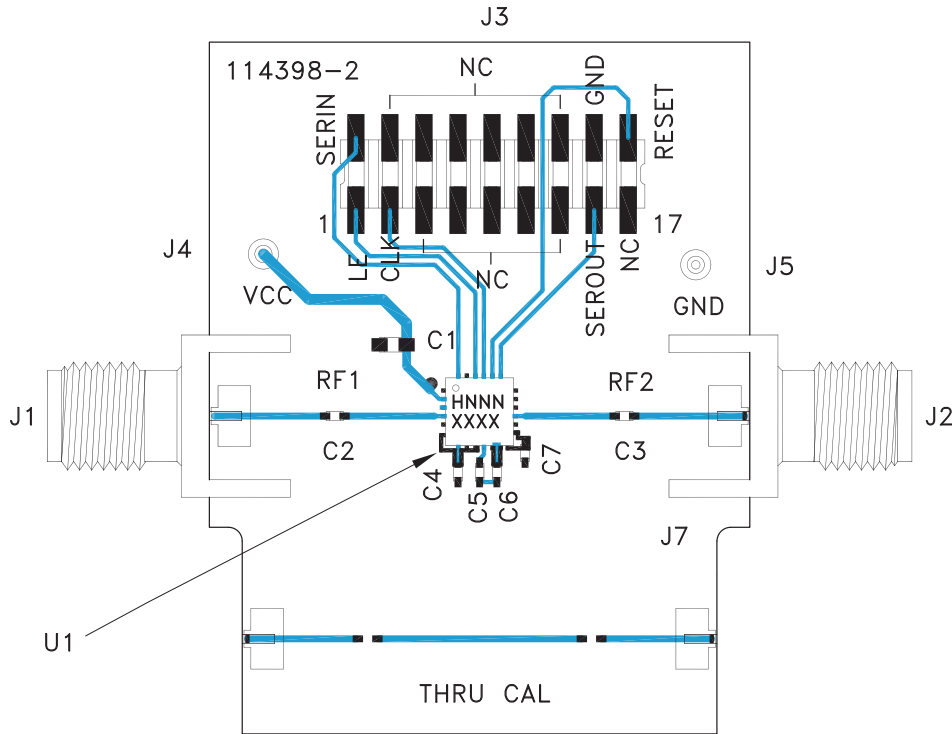

List of Materials for Evaluation PCB 114399 [1]

Item	Description
J1 - J2	PCB Mount SMA Connector
J3	18 Pin DC Connector
J4, J5	DC Pin
C1	1000 pF Capacitor, 0603 Pkg.
C2, C3	1000 pF Capacitor, 0402 Pkg.
C4 - C7	330 pF Capacitor, 0402 Pkg.
U1	HMC542ALP4(E) Digital Attenuator
PCB [2]	114398 Evaluation PCB

[1] Reference this number when ordering complete evaluation PCB

[2] Circuit Board Material: Rogers 4350 or Arlon 25FR

The circuit board used in the application should use RF circuit design techniques. Signal lines should have 50 Ohm impedance while the package ground leads and exposed paddle should be connected directly to the ground plane similar to that shown. A sufficient number of via holes should be used to connect the top and bottom ground planes. The evaluation circuit board shown is available from Hittite upon request.