

# TA1343N

## TV Sound Processor

TA1343N is a sound processor controlled by I<sup>2</sup>C bus. It incorporates the following: 2-channel input, 3-channel output signal processing circuit, phase shift circuit for surround, and LPF for woofer channel.

ALS (Automatic Level Suppressor) circuit which prevents distort the signal in large signal condition for woofer channel is also incorporated

### Features

- Sound processing circuit
  - 2 ch inputs (Lch, Rch)
  - 3 ch outputs (Lch, Rch, Wch)
  - Input matrix switch
  - Volume control
  - Bass, treble, and balance adjustment
  - Woofer level and surround effect level adjustment
  - ALS (automatic level suppresser) circuit
  - Built-in LPF for bass boost
- Surround circuit
  - Phase shift surround system
  - 2 modes stereo surround
  - Pseudo stereo mode

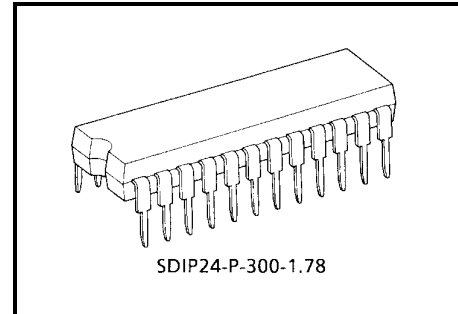

Weight: 1.22 g (typ.)

**Block Diagram**

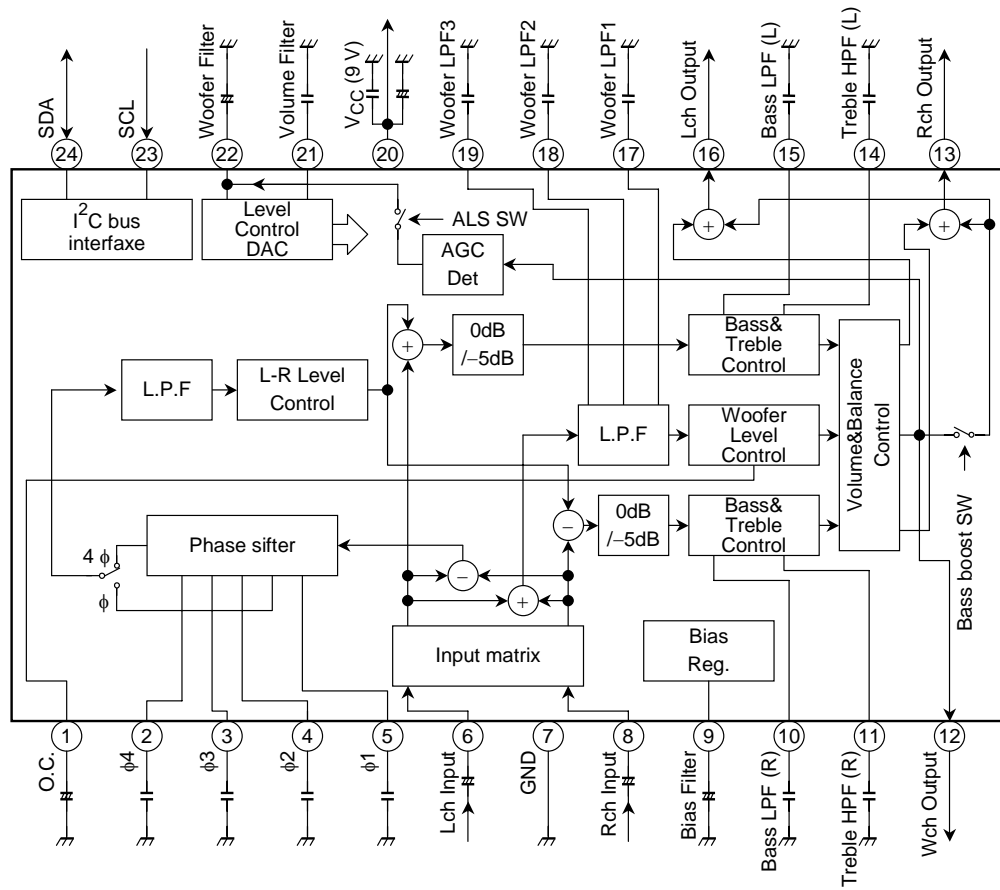

## Terminal Function

Pin No.	Name	Function	Interface Circuit
1	Offset canceling filter	DC offset canceling filter for bass boost. Connect a capacitor (10 μF) between this terminal and GND.	
2 3 4 5	φ4 φ3 φ2 φ1	Terminals for capacitors of the phase shift blocks. Value of phase shift each block is $\phi \text{ deg.} = -2 \tan^{-1} (2 \pi fCR)$ C is capacitance of external capacitor R is resistance of internal resistor (10 k Ω (typ.)).	
6 8	Lch Input Rch Input	Audio input terminals.	
7	GND	GND terminals.	
9	Bias Filter	Filter for noise rejection of the bias. Connect a capacitor (4.7 μF) between this terminal and GND.	

Pin No.	Name	Function	Interface Circuit
10 15	Bass LPF (R) Bass LPF (L)	LPFs for bass control circuits. Connect capacitors (0.027 $\mu$ F) between each terminals and GND.	
11 14	Treble HPF (R) Treble HPF (L)	HPFs for treble control circuits. Connect capacitors (8200 pF) between each terminals and GND.	
12 13 16	Wch Output Rch Output Lch Output	Audio output terminal.	
17 18 19	Woofer LPF 1 Woofer LPF 2 Woofer LPF 3	LPFs for bass boost circuit. Connect a capacitor (0.033 $\mu$ F) between terminal 17 and GND. Connect a capacitor (0.047 $\mu$ F) between terminal 18 and GND. Connect a capacitor (0.022 $\mu$ F) between terminal 19 and GND.	
20	V <sub>CC</sub>	V <sub>CC</sub> terminal. Recommended operation voltage is 9 V $\pm$ 10%.	

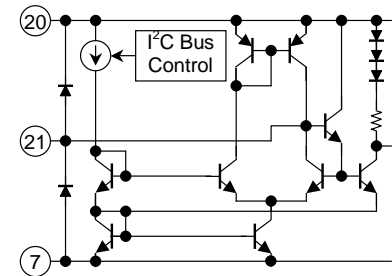
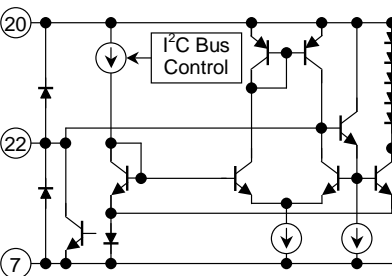
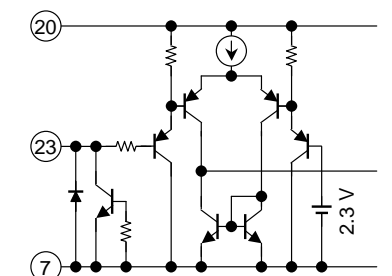
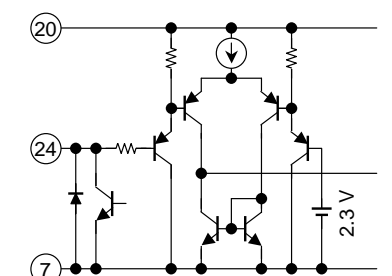
Pin No.	Name	Function	Interface Circuit
21	Volume Filter	Smoothing filter for volume control. Connect a capacitor (0.01 $\mu$ F) between this terminal and GND.	
22	Woofer Filter	Smoothing filter for bass boost level control. Connect a capacitor (3.3 $\mu$ F) between this terminal and GND. This filter is also for ALS circuit.	
23	SCL	SCL terminal.	
24	SDA	SDA terminal.	

**I<sup>2</sup>C Bus Control Data Table**

**Slave Address: 80 (h)**

**Address Map**

Sub Address	MSB (b7)	b6	b5	b4	b3	b2	b1	LSB (b0)	Default Data
00		Bass level (effective data range: 0E (h) to 72 (h))							40 (h) (Bass: Center)
01		Treble level (effective data range: 0E (h) to 72 (h))							40 (h) (Treble: Center)
02		Volume (effective data range: 00 (h) to 72 (h))							00 (h) (Volume: min)
03		ALS SW "0": OFF "1": ON	ALS start point "00": 220 mV "01": 380 mV "10": 525 mV "11": 770 mV			Input attenuati on "0": 0dB "1": -5dB	Input matrix "00": Normal "01": Rch "10": Lch "11": Reverse		00 (h) (ALS SW: OFF ALS start point: 220 mV Input attenuation: 0dB Input matrix: Normal)
04		Woofer level (effective data range: 00 (h) to 72 (h))							00 (h) (Woofer level: min)
05		Balance (effective data range: 00 (h) to 7F (h))							40 (h) (Balance: Center)
06	Surround mode 2 "0": Ste. "1": Mono.	Surround mode 1 "0": $\phi$ "1": 4 $\phi$				Surround effect level (effective data range 1 (h) to 7 (h)) 0 (h): OFF			C0 (h) (Surround mode 1: 4 $\phi$ Surround mode 2: Mono. Surround effect level: OFF)
07	Bass boost SW "0": OFF "1": ON		Woofer LPF fo "00": 100 Hz "01": 125 Hz "10": 170 Hz "11": 210 Hz			Woofer LPF defeat "0": OFF "1": ON	Muting 2 "0": OFF "1": ON	Muting 1 "0": OFF "1": ON	10 (h) Bass boost SW: OFF Woofer LPF fo: 125 Hz Muting 1: OFF Muting 2: OFF

The bits shown gray area must be "0".

## Block Diagram

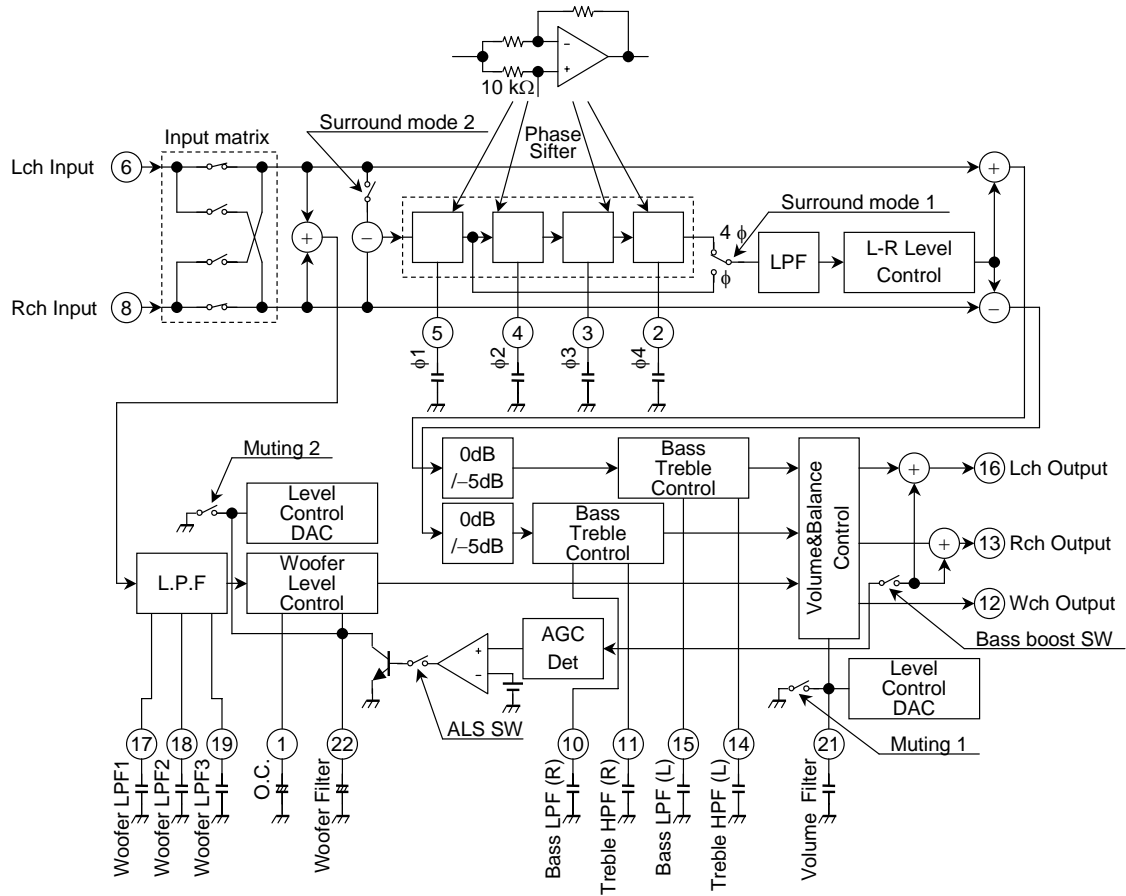

The on/off status of each switches drawn on this scheme shows the default setting of I<sup>2</sup>C bus control.

**Explanation of the Functions. (note: (h) means hexadecimal data, (b) means binary data)**

- Bass level control (sub address 00 (h))

Bass level control. Crossover frequency is 1 kHz.  
Effective control data range is 0E (h) to 72 (h) (100 steps). Set this data to 0E (h), bass level goes to minimum level, and set this data to 72 (h), bass level goes to maximum level. Set this data to 40 (h), bass level goes to center level.  
Switch on default data is 40 (h).  
Control range is  $\pm 12$ dB (typ.).
- Treble level control (sub address 01 (h))

Treble level control. Crossover frequency is 1 kHz.  
Effective control data range is 0E (h) to 72 (h) (100 steps). Set this data to 0E (h), treble level goes to minimum level, and set this data to 72 (h), treble level goes to maximum level. Set this data to 40 (h), treble level goes to center level.  
Switch on default data is 40 (h).  
Control range is  $\pm 12$ dB (typ.).
- Volume control (sub address 02 (h))

Volume control of only Lch and Rch output.  
Effective control data range is 00 (h) to 72 (h).  
Switch on default data is 00 (h).
- Woofer level control (sub address 04 (h))

Volume control of only Wch output.  
Effective control data range is 00 (h) to 72 (h).  
Switch on default data is 00 (h).
- Balance control (sub address 05 (h))

Balance control. Set this data to 40 (h), balance goes to center.  
Effective control data range is 00 (h) to 7F (h).  
Switch on default data is 40 (h).
- Surround effect level control (sub address 06 (h)/b2 to b0)

Surround effect level control.  
Effective control data range is 1 (h) to 7 (h). Set this data to 0 (h), surround function is off. Recommend setting surround 2 data to 1 (b) when surround effect level set to "0".  
Set mute on when surround effect level is changed.  
Switch on default data is 0 (h).
- Input matrix switch (sub address 03 (h)/b1 to b0)

Output signal selection control.  
Set these bits to 00 (b), output mode goes to normal mode (input signal of terminal 6 is outputted to terminal 16, and input signal of terminal 8 is outputted to terminal 13). Set these bits to 01 (b) output mode goes to Rch mode (input signal of terminal 8 is outputted to terminal 13 and terminal 16). Set these bits to 10 (b) output mode goes to Lch mode (input signal of terminal 6 is outputted to terminal 13 and terminal 16). Set these bits to 11 (b), output mode goes to reverse mode (input signal of terminal 6 is outputted to terminal 13, and input signal of terminal 8 is outputted to terminal 16).  
Switch on default data is 00 (b).
- Input attenuation (sub address 03 (h)/b2)

When this function is active, input signals are  $-5$ dB attenuated at input stage of Lch and Rch. Wch signal isn't attenuated.  
So, Wch output signal level is up to 5dB from Lch and Rch outputs relatively.  
Set the bit to 0 (b), attenuation is inactive, set the bit to 1 (b), attenuation is active.  
Switch on default data is 0 (b).



- ALS switch (sub address 03 (h)/b6), ALS start point (sub address 03 (h)/b5 to b4)

Gain of Wch is large. So output signals of Wch is distort easily when the input signals are large. ALS (Automatic Level Suppressor) suppresses Wch signal level under ALS start point, and reduces the distortion in large signals input condition.

Set the bit of sub address 03 (h)/b6 to 0 (b), ALS is inactive. Set the bit 1 to (b), ALS is active.

Switch on default data is 0 (b).

The bits of 03 (h)/b5 to b4 set ALS start point. Set the bits to 00 (b), ALS start point is 220 mV<sub>rms</sub>. Set the bits to 01 (b), ALS start point is 380 mV<sub>rms</sub>. Set the bits to 10 (b), ALS start point is 525 mV<sub>rms</sub>. And set the bits to 11 (b), ALS start point is 770 mV<sub>rms</sub>.

Switch on default data is 00 (b).

- Surround mode 1 (sub address 06 (h)/b6), Surround mode 2 (sub address 06 (h)/b7)

Surround mode 1 is selection of phase shift value of the surround circuit. Set the bit to 0 (b), L-R signal is shifted by 1 phase shift stage. Set the bit to 1 (b), L-R signal is shifted by 4 phase shift stages.

Surround mode 2 is selected by condition of the input signal. When input signal is stereo, surround mode 2 must be set to 0 (b). When input signal is monaural, surround mode 2 must be set to 1 (b) (pseudo stereo mode).

Recommend setting surround 1 to 1 (b) when pseudo stereo mode is selected.

- Mute 1 (sub address 07 (h)/b0), Mute 2 (sub address 07 (h)/b1)

When Mute 1 is active, all outputs are muted.

Set the bit to 0 (b), mute 1 is inactive. Set the bit to 1 (b), Mute 1 is active.

Switch on default data is 0 (b).

When Mute 2 is active, only Wch output is muted. Set the bit to 0 (b), Mute 2 is inactive. Set the bit to 1 (b), Mute 2 is active.

Switch on default data is 0 (b).

- Woofers LPF fo (sub address 07 (h)/b5 to b4)

These bits set cut off frequency (fo) of the low pass filter for Wch.

Set the bits to 00 (b), fo is 100 Hz (-3dB point). Set the bits to 01 (b), fo is 125 Hz. Set the bits to 10 (b), fo is 170 Hz. Set the bits to 11 (b), fo is 210 Hz.

Switch on default data is 01 (h).

- Woofers LPF defeat (sub address 07 (h)/b3)

Set the bit to 1 (b), Woofers LPF is defeated.

This function is for device test. So, this bit must be set to 0 (b).

Switch on default data is 0 (b).

- Bass boost switch (sub address 07 (h)/b7)

Bass boost function is adding Wch signal to main channel signals. It can boost low frequency signal without woofers output.

Set the bit 0 (b), Bass boost is inactive. Set the bit 1 (b), bass boost is active.

Switch on default data is 0 (b).

Purchase of TOSHIBA I<sup>2</sup>C components conveys a license under the Philips I<sup>2</sup>C Patent Rights to use these components in an I<sup>2</sup>C system, provided that the system conforms to the I<sup>2</sup>C Standard Specification as define by Philips.

## Maximum Ratings (Ta = 25°C)

Characteristics	Symbol	Rating	Unit
Supply voltage	V <sub>CC</sub>	12	V
Power dissipation	P <sub>D</sub>	1400 (Note 1)	mW
Operating temperature	T <sub>opr</sub>	-20 to 75	°C
Storage temperature	T <sub>stg</sub>	-55 to 150	°C
Maximum input voltage	V <sub>MAX</sub>	V <sub>CC</sub> + 0.3	V
Minimum input voltage	V <sub>MIN</sub>	V <sub>CC</sub> - 0.3	V

Note 1: When using the device at Ta = 25°C, decrease the power dissipation by 11.2 mW for each increase of 1°C

## Recommended Supply Voltage

Pin No.	Pin Name	Min	Typ.	Max	Unit
20	V <sub>CC</sub>	8.1	9.0	9.9	V

## Electrical Characteristics

### DC Characteristics (V<sub>CC</sub> = 9 V, Ta = 25°C)

Characteristics	Pin No.	Pin Name	Symbol	Test Circuit	Test Condition	Min	Typ.	Max	Unit
Power dissipation	20	V <sub>CC</sub>	I <sub>CC</sub>			39	50	63	mA
Pin voltage	1	Offset canceling filter	V1	1	In power on default	4.0	4.5	5.0	V
	2	φ4	V2			4.0	4.5	5.0	
	3	φ3	V3			4.0	4.5	5.0	
	4	φ2	V4			4.0	4.5	5.0	
	5	φ1	V5			4.0	4.5	5.0	
	6	Lch Input	V6			4.0	4.5	5.0	
	8	Rch Input	V8			4.0	4.5	5.0	
	9	Bias Filter	V9			5.2	5.7	6.2	
	10	Bass LPF (R)	V10			4.0	4.5	5.0	
	11	Treble LPF (R)	V11			4.0	4.5	5.0	
	12	Wch Output	V12			4.0	4.5	5.0	
	13	Rch Output	V13			4.0	4.5	5.0	
	14	Treble LPF (L)	V14			4.0	4.5	5.0	
	15	Bass LPF (L)	V15			4.0	4.5	5.0	
	16	Lch Output	V16			4.0	4.5	5.0	
	17	Woofer LPF1	V17			4.6	5.1	5.6	
	18	Woofer LPF2	V18			4.6	5.1	5.6	
	19	Woofer LPF3	V19			4.6	5.1	5.6	
		21	Volume Filter			V21	—	0.0	
	22	Woofer Filter	V22	0.5	1.5	2.0			

**AC Characteristics (V<sub>CC</sub> = 9 V, Ta = 25°C)**

Characteristics	Symbol	Test Circuit	Test Condition	Min	Typ.	Max	Unit
Gain	Go L	—	(Note 1)	0.0	2.0	4.0	dB
	Go R	—					
	GoAtt L	—		-7.0	-5.0	-3.0	
	GoAtt R	—					
	GoBst L	—		11.0	13.0	15.0	
	GoBst R	—					
	Go W	—		16.0	19.0	22.0	
THD	THD L	—	(Note 2)	—	0.03	1.0	%
	THD R	—			0.25		
	THD W	—					
S/N	SN L	—	(Note 3)	70	74	—	dB
	SN R	—					
	SN W	—		68	72		
Residual noise	v <sub>NO</sub> L	—	(Note 4)	—	20	50	μV <sub>rms</sub>
	v <sub>NO</sub> R	—					
	v <sub>NO</sub> W	—					
Frequency response (100 Hz)	Go100 L	—	(Note 5)	-2.0	0.0	2.0	dB
	Go100 R	—					
Frequency response (10 kHz)	Go10k L	—	(Note 6)	-2.0	0.0	2.0	dB
	Go10k R	—					
	Go10k S	—		-13.0	-11.0	-8.0	
LPF frequency response	G <sub>LPF</sub> 100	—	(Note 7)	4.0	6.0	8.0	dB
	G <sub>LPF</sub> 125	—					
	G <sub>LPF</sub> 170	—		4.0	6.0	8.0	
	G <sub>LPF</sub> 210	—					
Surround sound gain	G S	—	(Note 8)	1.5	3.5	5.5	dB
Surround sound phase	Ph 4 φ	—	(Note 9)	-65	-110	-65	deg.
Balance center	ΔG <sub>LR</sub>	—	(Note 10)	-2.0	0.0	2.0	dB
Balance minimum	G <sub>B</sub> MIN L	—	(Note 11)	—	-70	-60	dB
	G <sub>B</sub> MIN R	—					
Bass maximum	G <sub>B</sub> MAX L	—	(Note 12)	9	12	14	dB
	G <sub>B</sub> MAX R	—					
Bass minimum	G <sub>B</sub> MIN L	—	(Note 13)	-14	-12	-9	dB
	G <sub>B</sub> MIN R	—					
Treble maximum	G <sub>T</sub> MAX L	—	(Note 14)	9	12	14	dB
	G <sub>T</sub> MAX R	—					
Treble minimum	G <sub>T</sub> MIN L	—	(Note 15)	-14	-12	-9	dB
	G <sub>T</sub> MIN R	—					
Volume center	G <sub>V</sub> LCNT L	—	(Note 16)	-17	-15	-12	dB
	G <sub>V</sub> LCNT R	—					
	G <sub>V</sub> LCNT W	—					

Characteristics	Symbol	Test Circuit	Test Condition	Min	Typ.	Max	Unit
Volume minimum	GVLMIN L	—	(Note 17)	—	-77	-65	dB
	GVLMIN R	—					
	GVLMIN W	—					
Woofers level center	GWLCNT	—	(Note 18)	-9.5	-7.5	-5.5	dB
ALS start point 0	VALS0	—	(Note 19)	185	220	255	mV <sub>rms</sub>
ALS start point 1	VALS1	—		325	380	430	mV <sub>rms</sub>
ALS start point 2	VALS2	—		460	525	585	mV <sub>rms</sub>
ALS start point 3	VALS3	—		655	770	880	mV <sub>rms</sub>
Cross talk	CTL-R	—	(Note 20)	—	-82	-72	dB
	CTR-L	—					
Ripple rejection (volume minimum)	RR1 L	—	(Note 21)	—	-48	-30	dB
	RR1 R	—			-53		
	RR1 W	—					
Ripple rejection (volume maximum)	RR2 L	—	(Note 22)	—	-42	-30	dB
	RR2 R	—					
	RR2 W	—			-32		
Output dynamic range	VDOUT L	—	(Note 23)	6.0	6.7	—	V <sub>p-p</sub>
	VDOUT R	—		5.5	6.3		
	VDOUT W	—		6.0	6.7		
Input dynamic range	VDIN L	—	(Note 24)	5.5	7.5	—	V <sub>p-p</sub>
	VDIN R	—					
	VDIN W	—		3.0	4.5		
DC offset (muting)	ΔV <sub>M</sub> L	—	(Note 25)	—	—	±380	mV
	ΔV <sub>M</sub> R	—					
	ΔV <sub>M</sub> W	—					
DC offset (surround switch)	ΔV <sub>S</sub> L	—	(Note 26)	—	—	±50	mV
	ΔV <sub>S</sub> R	—					
Mute residual level	GMUT L	—	(Note 27)	—	-90	-70	dB
	GMUT R	—					
	GMUT W	—					

Test Condition

Note	Test Condition											
	Input Point	Meas. Point	Bus Data (hexadecimal)								SW1	
			00	01	02	03	04	05	06	07		
1	TP6 TP8	TP12 TP13 TP16	40	40	72	00 / 04	72	40	C0	10 / 90	(a)	<ul style="list-style-type: none"> <li>Set data of sub address 03 (h) to 00 (h) and set data of sub address 07 (h) to 10 (h).</li> <li>Input signal (1 kHz, 500 mV<sub>rms</sub>, sine wave) to TP6 and TP8.</li> <li>Measure amplitude of T13 and TP16 (v13<sub>1</sub> mV<sub>rms</sub>, v16<sub>1</sub> mV<sub>rms</sub>).</li> <li>Go RdB = 20log (v13<sub>1</sub>/500) Go LdB = 20log (v16<sub>1</sub>/500)</li> <li>Set data of sub address 03 (h) to 04 (h).</li> <li>Measure amplitude of T13 and TP16 (v13<sub>2</sub> mV<sub>rms</sub>, v16<sub>2</sub> mV<sub>rms</sub>).</li> <li>Go<sub>Att</sub> RdB = 20log (v13<sub>2</sub>/v13<sub>1</sub>) Go<sub>Att</sub> LdB = 20log (v16<sub>2</sub>/v16<sub>1</sub>)</li> <li>Set data of sub address 03 (h) to 00 (h) and set data of sub address 07 (h) to 10 (h).</li> <li>Input signal (80 Hz, 100 mV<sub>rms</sub>, sine wave) to TP6 and TP8.</li> <li>Measure amplitude of T13 and TP16 (v13<sub>3</sub> mV<sub>rms</sub>, v16<sub>3</sub> mV<sub>rms</sub>).</li> <li>Set data sub address 07 (h) to 90 (h).</li> <li>Measure amplitude of T13 and TP16 (v13<sub>4</sub> mV<sub>rms</sub>, v16<sub>4</sub> mV<sub>rms</sub>).</li> <li>GoBst RdB = 20log (v13<sub>4</sub>/v13<sub>3</sub>) GoBst LdB = 20log (v16<sub>4</sub>/v16<sub>3</sub>)</li> <li>Measure amplitude of TP12 (v12 mV<sub>rms</sub>).</li> <li>Go WdB = 20log (v12/100)</li> </ul>
2	TP6 TP8	TP12 TP13 TP16	40	40	72	00	72	40	C0	10	(a)	<ul style="list-style-type: none"> <li>Input signal (1 kHz, 500 mV<sub>rms</sub>, sine wave) to TP6 and TP8.</li> <li>Measure THD of TP13 and TP 16 (THD R%, THD L%).</li> <li>Input signal (80 Hz, 100 mV<sub>rms</sub>, sine wave) to TP6 and TP8.</li> <li>Measure THD of TP12 (THD W%)</li> </ul>
3	TP6 TP8	TP12 TP13 TP16	40	40	72	00	72	40	C0	10	(a)	<ul style="list-style-type: none"> <li>Input signal (1 kHz, 500 mV<sub>rms</sub>, sine wave) to TP6 and TP8.</li> <li>Measure amplitude of T13 and TP16 (v13<sub>s</sub> mV<sub>rms</sub>, v16<sub>s</sub> mV<sub>rms</sub>).</li> <li>Connect TP6 and TP8 to GND.</li> <li>Measure amplitude of T13 and TP16 (v13<sub>n</sub> mV<sub>rms</sub>, v16<sub>n</sub> mV<sub>rms</sub>).</li> <li>SN RdB = 20log (v13<sub>s</sub>/v13<sub>n</sub>) SN LdB = 20log (v16<sub>s</sub>/v16<sub>n</sub>)</li> <li>Input signal (80 Hz, 100 mV<sub>rms</sub>, sine wave) to TP6 and TP8.</li> <li>Measure amplitude of T12 (v12<sub>s</sub> mV<sub>rms</sub>).</li> <li>Connect TP6 and TP8 to GND.</li> <li>Measure amplitude of T12 (v12<sub>n</sub> mV<sub>rms</sub>).</li> <li>SN WdB = 20log (v12<sub>s</sub>/v12<sub>n</sub>)</li> </ul>
4	—	TP12 TP13 TP16	40	40	00	00	00	40	C0	10	(a)	<ul style="list-style-type: none"> <li>Connect TP6 and TP8 to GND.</li> <li>Measure amplitude of TP12, TP13 and TP16 (v<sub>NO W</sub> μV<sub>rms</sub>, v<sub>NO R</sub> μV<sub>rms</sub>, v<sub>NO L</sub> μV<sub>rms</sub>).</li> </ul>

Note	Test Condition											
	Input Point	Meas. Point	Bus Data (hexadecimal)								SW1	
			00	01	02	03	04	05	06	07		
5	TP6 TP8	TP13 TP16	40	40	72	00	00	40	C0	10	(a)	<ul style="list-style-type: none"> <li>Input signal (1 kHz, 500 mV<sub>rms</sub>, sine wave) to TP6 and TP8.</li> <li>Measure amplitude of T13 and TP16 (v13<sub>0</sub> mV<sub>rms</sub>, v16<sub>0</sub> mV<sub>rms</sub>).</li> <li>Input signal (100 Hz, 500 mV<sub>rms</sub>, sine wave) to TP6 and TP8.</li> <li>Measure amplitude of T13 and TP16 (v13 mV<sub>rms</sub>, v16 mV<sub>rms</sub>).</li> <li>G100 RdB = 20log (v13/v13<sub>0</sub>) G100 LdB = 20log (v16/v16<sub>0</sub>)</li> </ul>
6	TP6 TP8	TP13 TP16	40	40	72	00	00	40	C0 / C7	10	(a)	<ul style="list-style-type: none"> <li>Set data of sub address 06 (h) to 00 (h).</li> <li>Input signal (1 kHz, 500 mV<sub>rms</sub>, sine wave) to TP6 and TP8.</li> <li>Measure amplitude of T13 and TP16 (v13<sub>0</sub> mV<sub>rms</sub>, v16<sub>0</sub> mV<sub>rms</sub>).</li> <li>Input signal (10 kHz, 500 mV<sub>rms</sub>, sine wave) to TP6 and TP8.</li> <li>Measure amplitude of T13 and TP16 (v13<sub>1</sub> mV<sub>rms</sub>, v16<sub>1</sub> mV<sub>rms</sub>).</li> <li>G10k RdB = 20log (v13<sub>1</sub>/v13<sub>0</sub>) G10k LdB = 20log (v16<sub>1</sub>/v16<sub>0</sub>)</li> <li>Set data of sub address 06 (h) to C7 (h).</li> <li>Connect TP6 to GND.</li> <li>Input signal (1 kHz, 500 mV<sub>rms</sub>, sine wave) to TP8.</li> <li>Measure amplitude of T16 (v16<sub>2</sub> mV<sub>rms</sub>).</li> <li>Input signal (10 kHz, 500 mV<sub>rms</sub>, sine wave) to TP8.</li> <li>Measure amplitude of T16 (v16<sub>3</sub> mV<sub>rms</sub>).</li> <li>G10k SdB = 20log (v16<sub>3</sub>/v16<sub>2</sub>)</li> </ul>
7	TP6 TP8	TP12	40	40	72	00	00	40	C0 / 10 / 20 / 30 / 14	00 / 10 / 20 / 30 / 14	(a)	<ul style="list-style-type: none"> <li>Input signal (300 Hz, 100 mV<sub>rms</sub>, sine wave) to TP6 and TP8.</li> <li>Set data of sub address 07 (h) to 00 (h).</li> <li>Measure amplitude of TP12 (v12<sub>0</sub> mV<sub>rms</sub>).</li> <li>Set data of sub address 07 (h) to 10 (h).</li> <li>Measure amplitude of TP12 (v12<sub>1</sub> mV<sub>rms</sub>).</li> <li>Set data of sub address 07 (h) to 20 (h).</li> <li>Measure amplitude of TP12 (v12<sub>2</sub> mV<sub>rms</sub>).</li> <li>Set data of sub address 07 (h) to 30 (h).</li> <li>Measure amplitude of TP12 (v12<sub>3</sub> mV<sub>rms</sub>).</li> <li>Set data of sub address 07 (h) to 14 (h).</li> <li>Measure amplitude of TP12 (v12<sub>x</sub> mV<sub>rms</sub>).</li> <li>G<sub>LPF</sub>100dB = 20log (v12<sub>0</sub>/v12<sub>1</sub>) G<sub>LPF</sub>125dB = 20log (v12<sub>1</sub>/v12<sub>2</sub>) G<sub>LPF</sub>170dB = 20log (v12<sub>2</sub>/v12<sub>3</sub>) G<sub>LPF</sub>210dB = 20log (v12<sub>3</sub>/v12<sub>x</sub>)</li> </ul>

Note	Test Condition											
	Input Point	Meas. Point	Bus Data (hexadecimal)								SW1	
			00	01	02	03	04	05	06	07		
8	TP6 TP8	TP16	40	40	72	00	00	40	C0 / C7	10	(a)	<ul style="list-style-type: none"> <li>Set data of sub address 06 (h) to C0 (h).</li> <li>Connect TP8 to GND and input signal (1 kHz, 500 mV<sub>rms</sub>, sine wave) to TP6.</li> <li>Measure amplitude of TP16 (v16<sub>0</sub> mV<sub>rms</sub>).</li> <li>Set data of sub address 06 (h) to C7 (h).</li> <li>Connect TP6 to GND and input signal (1 kHz, 500 mV<sub>rms</sub>, sine wave) to TP8.</li> <li>Measure amplitude of TP16 (v16<sub>1</sub> mV<sub>rms</sub>).</li> <li>G SdB = 20log (v16<sub>1</sub>/v16<sub>0</sub>)</li> </ul>
9	TP8	TP16	40	40	72	00	00	40	C7	10	(a)	<ul style="list-style-type: none"> <li>Connect TP6 to GND.</li> <li>Input signal (400 Hz, 500 mV<sub>rms</sub>, sine wave) to TP8.</li> <li>Measure phase between TP8 and TP16 (Ph 4 φ deg.).</li> </ul>
10	TP6 TP8	TP13 TP16	40	40	72	00	00	40	C0	10	(a)	<ul style="list-style-type: none"> <li>Input signal (1 kHz, 500 mV<sub>rms</sub>, sine wave) to TP6 and TP8.</li> <li>Measure amplitude of TP13 and TP16 (v13 mV<sub>rms</sub>, v16 mV<sub>rms</sub>).</li> <li>ΔGLRdB = 20log (v16/V13)</li> </ul>
11	TP6 TP8	TP13 TP16	40	40	72	00	00	0E / 72	C0	10	(a)	<ul style="list-style-type: none"> <li>Input signal (1 kHz, 500 mV<sub>rms</sub>, sine wave) to TP6 and TP8.</li> <li>Set data of sub address 05 (h) to 0E (h).</li> <li>Measure amplitude of TP13 and TP16 (v13<sub>R</sub> mV<sub>rms</sub>, v16<sub>R</sub> mV<sub>rms</sub>).</li> <li>Set data of sub address 05 (h) to 72 (h).</li> <li>Measure amplitude of TP13 and TP16 (v13<sub>L</sub> mV<sub>rms</sub>, v16<sub>L</sub> mV<sub>rms</sub>).</li> <li>G<sub>BLMIN</sub> R = 20log (v13<sub>R</sub>/v16<sub>R</sub>) G<sub>BLMIN</sub> L = 20log (v16<sub>L</sub>/v13<sub>L</sub>)</li> </ul>
12	TP6 TP8	TP13 TP16 / 72	40	40	72	00	00	40	C0	10	(a)	<ul style="list-style-type: none"> <li>Input signal (100 Hz, 250 mV<sub>rms</sub>, sine wave) to TP6 and TP8.</li> <li>Set data of sub address 00 (h) to 40 (h).</li> <li>Measure amplitude of TP13 and TP16 (v13<sub>0</sub> mV<sub>rms</sub>, v16<sub>0</sub> mV<sub>rms</sub>).</li> <li>Set data of sub address 00 (h) to 72 (h).</li> <li>Measure amplitude of TP13 and TP16 (v13<sub>B</sub> mV<sub>rms</sub>, v16<sub>B</sub> mV<sub>rms</sub>).</li> <li>G<sub>BMAX</sub> R = 20log (v13<sub>B</sub>/v13<sub>0</sub>) G<sub>BMAX</sub> L = 20log (v16<sub>B</sub>/v13<sub>0</sub>)</li> </ul>
13	TP6 TP8	TP13 TP16 / 0E	40	40	72	00	00	40	C0	10	(a)	<ul style="list-style-type: none"> <li>Input signal (100 Hz, 250 mV<sub>rms</sub>, sine wave) to TP6 and TP8.</li> <li>Set data of sub address 00 (h) to 40 (h).</li> <li>Measure amplitude of TP13 and TP16 (v13<sub>0</sub> mV<sub>rms</sub>, v16<sub>0</sub> mV<sub>rms</sub>).</li> <li>Set data of sub address 00 (h) to 0E (h).</li> <li>Measure amplitude of TP13 and TP16 (v13<sub>B</sub> mV<sub>rms</sub>, v16<sub>B</sub> mV<sub>rms</sub>).</li> <li>G<sub>BMIN</sub> R = 20log (v13<sub>B</sub>/v13<sub>0</sub>) G<sub>BMIN</sub> L = 20log (v16<sub>B</sub>/v13<sub>0</sub>)</li> </ul>

Note	Test Condition											
	Input Point	Meas. Point	Bus Data (hexadecimal)								SW1	
			00	01	02	03	04	05	06	07		
14	TP6 TP8	TP13 TP16	40	40 / 72	72	00	00	40	C0	10	(a)	<ul style="list-style-type: none"> <li>Input signal (10 kHz, 250 mV<sub>rms</sub>, sine wave) to TP6 and TP8.</li> <li>Set data of sub address 01 (h) to 40 (h).</li> <li>Measure amplitude of TP13 and TP16 (v13<sub>0</sub> mV<sub>rms</sub>, v16<sub>0</sub> mV<sub>rms</sub>).</li> <li>Set data of sub address 01 (h) to 72 (h).</li> <li>Measure amplitude of TP13 and TP16 (v13<sub>T</sub> mV<sub>rms</sub>, v16<sub>T</sub> mV<sub>rms</sub>).</li> <li>G<sub>TRMAX</sub> R = 20log (v13<sub>T</sub>/v13<sub>0</sub>) G<sub>TRMAX</sub> L = 20log (v16<sub>T</sub>/v13<sub>0</sub>)</li> </ul>
15	TP6 TP8	TP13 TP16	40	40 / 0E	72	00	00	40	C0	10	(a)	<ul style="list-style-type: none"> <li>Input signal (10 kHz, 250 mV<sub>rms</sub>, sine wave) to TP6 and TP8.</li> <li>Set data of sub address 01 (h) to 40 (h).</li> <li>Measure amplitude of TP13 and TP16 (v13<sub>0</sub> mV<sub>rms</sub>, v16<sub>0</sub> mV<sub>rms</sub>).</li> <li>Set data of sub address 01 (h) to 0E (h).</li> <li>Measure amplitude of TP13 and TP16 (v13<sub>T</sub> mV<sub>rms</sub>, v16<sub>T</sub> mV<sub>rms</sub>).</li> <li>G<sub>TRMIN</sub> R = 20log (v13<sub>T</sub>/v13<sub>0</sub>) G<sub>TRMIN</sub> L = 20log (v16<sub>T</sub>/v13<sub>0</sub>)</li> </ul>
16	TP6 TP8	TP12 TP13 TP16	40	40	72 / 40	00	72	40	C0	10	(a)	<ul style="list-style-type: none"> <li>Input signal (1 kHz, 500 mV<sub>rms</sub>, sine wave) to TP6 and TP8.</li> <li>Set data of sub address 02 (h) to 72 (h).</li> <li>Measure amplitude of TP13 and TP16 (v13<sub>0</sub> mV<sub>rms</sub>, v16<sub>0</sub> mV<sub>rms</sub>).</li> <li>Set data of sub address 02 (h) to 40 (h).</li> <li>Measure amplitude of TP13 and TP16 (v13<sub>C</sub> mV<sub>rms</sub>, v16<sub>C</sub> mV<sub>rms</sub>).</li> <li>G<sub>VRCNT</sub> R = 20log (v13<sub>C</sub>/v13<sub>0</sub>) G<sub>VRCNT</sub> L = 20log (v16<sub>C</sub>/v13<sub>0</sub>)</li> <li>Input signal (80 Hz, 100 mV<sub>rms</sub>, sine wave) to TP6 and TP8.</li> <li>Set data of sub address 02 (h) to 72 (h).</li> <li>Measure amplitude of TP12 (v12<sub>0</sub> mV<sub>rms</sub>).</li> <li>Set data of sub address 02 (h) to 40 (h).</li> <li>Measure amplitude of TP12 (v12<sub>C</sub> mV<sub>rms</sub>).</li> <li>G<sub>VRCNT</sub> W = 20log (v12<sub>C</sub>/v12<sub>0</sub>)</li> </ul>



Note	Test Condition											
	Input Point	Meas. Point	Bus Data (hexadecimal)								SW1	
			00	01	02	03	04	05	06	07		
17	TP6 TP8	TP12 TP13 TP16	40	40	72 / 0E	00	72	40	C0	10	(a)	<ul style="list-style-type: none"> <li>Input signal (1 kHz, 500 mV<sub>rms</sub>, sine wave) to TP6 and TP8.</li> <li>Set data of sub address 02 (h) to 72 (h).</li> <li>Measure amplitude of TP13 and TP16 (v13<sub>0</sub> mV<sub>rms</sub>, v16<sub>0</sub> mV<sub>rms</sub>).</li> <li>Set data of sub address 02 (h) to 0E (h).</li> <li>Measure amplitude of TP13 and TP16 (v13<sub>MIN</sub> mV<sub>rms</sub>, v16<sub>MIN</sub> mV<sub>rms</sub>).</li> <li>G<sub>VRMIN R</sub> = 20log (v13<sub>MIN</sub>/v13<sub>0</sub>) G<sub>VRMIN L</sub> = 20log (v16<sub>MIN</sub>/v13<sub>0</sub>)</li> <li>Input signal (80 Hz, 100 mV<sub>rms</sub>, sine wave) to TP6 and TP8.</li> <li>Set data of sub address 02 (h) to 72 (h).</li> <li>Measure amplitude of TP12 (v12<sub>0</sub> mV<sub>rms</sub>).</li> <li>Set data of sub address 02 (h) to 0E (h).</li> <li>Measure amplitude of TP12 (v12<sub>MIN</sub> mV<sub>rms</sub>).</li> <li>G<sub>VRMIN W</sub> = 20log (v12<sub>MIN</sub>/v12<sub>0</sub>)</li> </ul>
18	TP6 TP8	TP12	40	40	72	00	72 / 40	40	C0	10	(a)	<ul style="list-style-type: none"> <li>Input signal (80 Hz, 100 mV<sub>rms</sub>, sine wave) to TP6 and TP8.</li> <li>Set data of sub address 04 (h) to 72 (h).</li> <li>Measure amplitude of TP12 (v12<sub>0</sub> mV<sub>rms</sub>).</li> <li>Set data of sub address 04 (h) to 40 (h).</li> <li>Measure amplitude of TP12 (v12<sub>C</sub> mV<sub>rms</sub>).</li> <li>G<sub>WLCNT</sub> = 20log (v12<sub>C</sub>/v12<sub>0</sub>)</li> </ul>
19	TP6 TP8	TP12	40	40	72	40 / 50 / 60 / 70	72	40	C0	10	(a)	<ul style="list-style-type: none"> <li>Input signal (80 Hz, 500 mV<sub>rms</sub>, sine wave) to TP6 and TP8.</li> <li>Set data of sub address 03 (h) to 40 (h).</li> <li>Measure amplitude of TP12 (vALS0 mV<sub>rms</sub>)</li> <li>Set data of sub address 03 (h) to 50 (h).</li> <li>Measure amplitude of TP12 (vALS1 mV<sub>rms</sub>)</li> <li>Set data of sub address 03 (h) to 60 (h).</li> <li>Measure amplitude of TP12 (vALS2 mV<sub>rms</sub>)</li> <li>Set data of sub address 03 (h) to 70 (h).</li> <li>Measure amplitude of TP12 (vALS3 mV<sub>rms</sub>)</li> </ul>
20	TP6 TP8	TP13 TP16	40	40	72	00	00	40	C0	10	(a)	<ul style="list-style-type: none"> <li>Connect TP8 to GND.</li> <li>Input signal (1 kHz, 500 mV<sub>rms</sub>, sine wave) to TP6.</li> <li>Measure 1 kHz spectrum of TP16 (v16<sub>1</sub> dBμV).</li> <li>Measure 1 kHz spectrum of TP13 (v13<sub>1</sub> dBμV).</li> <li>CT<sub>L-R</sub> = 20log (v13<sub>1</sub> - v16<sub>1</sub>)</li> <li>Connect TP6 to GND.</li> <li>Input signal (1 kHz, 500 mV<sub>rms</sub>, sine wave) to TP8.</li> <li>Measure 1 kHz spectrum of TP13 (v13<sub>2</sub> dBμV).</li> <li>Measure 1 kHz spectrum of TP16 (v16<sub>2</sub> dBμV).</li> <li>CT<sub>R-L</sub> = 20log (v16<sub>2</sub> - v13<sub>2</sub>)</li> </ul>

Note	Test Condition											
	Input Point	Meas. Point	Bus Data (hexadecimal)								SW1	
			00	01	02	03	04	05	06	07		
21	TP6 TP8	TP12 TP13 TP16	40	40	00	00	00	40	C0	10	(b)	<ul style="list-style-type: none"> <li>Connect TP6 and TP8 to GND.</li> <li>Apply 9.0 V DC and sine wave (60Hz, 500 mV<sub>rms</sub>) to V<sub>CC</sub> terminal.</li> <li>Measure amplitude of TP12, TP13 and TP16 (v12 mV<sub>rms</sub>, v13 mV<sub>rms</sub>, v16 mV<sub>rms</sub>).</li> <li>RR1 WdB = 20log (v12/500) RR1 RdB = 20log (v13/500) RR1 LdB = 20log (v16/500)</li> </ul>
22	TP6 TP8	TP12 TP13 TP16	40	40	72	00	72	40	C0	10	(b)	<ul style="list-style-type: none"> <li>Connect TP6 and TP8 to GND.</li> <li>Apply 9.0 V DC and sine wave (60Hz, 500 mV<sub>rms</sub>) to V<sub>CC</sub> terminal.</li> <li>Measure amplitude of TP12, TP13 and TP16 (v12 mV<sub>rms</sub>, v13 mV<sub>rms</sub>, v16 mV<sub>rms</sub>).</li> <li>RR2 WdB = 20log (v12/500) RR2 RdB = 20log (v13/500) RR2 LdB = 20log (v16/500)</li> </ul>
23	TP6 TP8	TP12 TP13 TP16	72	72	72	00	72	40	C0	10	(a)	<ul style="list-style-type: none"> <li>Input signal (100 Hz, sine wave) to TP6 and TP8.</li> <li>Increase amplitude of the input signal, and measure THD of TP13 and TP16. Measure amplitude of TP13 and TP16 when THD of the outputs are 1% (v<sub>DOUT R1</sub> V<sub>p-p</sub>, v<sub>DOUT L1</sub> V<sub>p-p</sub>).</li> <li>Input signal (10 kHz, sine wave) to TP6 and TP8.</li> <li>Increase amplitude of the input signal, and measure THD of TP13 and TP16. Measure amplitude of TP13 and TP16 when THD of the outputs are 1% (v<sub>DOUT R2</sub> V<sub>p-p</sub>, v<sub>DOUT L2</sub> V<sub>p-p</sub>).</li> <li>Smaller value v<sub>DOUT R1</sub> or v<sub>DOUT R2</sub> is v<sub>DOUT R</sub>. Smaller value v<sub>DOUT L1</sub> or v<sub>DOUT L2</sub> is v<sub>DOUT L</sub>.</li> <li>Input signal (80 Hz, sine wave) to TP6 and TP8.</li> <li>Increase amplitude of the input signal, and measure THD of TP 12. Measure amplitude of TP12 when THD of the output is 1% (v<sub>DOUT W</sub> V<sub>p-p</sub>).</li> </ul>
24	TP6 TP8	TP12 TP13 TP16	40	40	40	00	40	40	C0	10	(a)	<ul style="list-style-type: none"> <li>Input signal (1 kHz, sine wave) to TP6 and TP8.</li> <li>Increase amplitude of the input signal, and measure THD of TP13 and TP16. Measure amplitude of TP6 and TP8 when THD of the outputs are 1% (v<sub>DIN R</sub> V<sub>p-p</sub>, v<sub>DIN L</sub> V<sub>p-p</sub>).</li> <li>Input signal (80 Hz, sine wave) to TP6 and TP8.</li> <li>Increase amplitude of the input signal, and measure THD of TP 12. Measure amplitude of TP6 and TP8 when THD of the outputs are 1% (v<sub>DIN W</sub> V<sub>p-p</sub>).</li> </ul>
25	TP6 TP8	TP12 TP13 TP16	40	40	72	00	72	40	C0	10 / 11 / 12	(a)	<ul style="list-style-type: none"> <li>Connect TP6 and TP8 to GND.</li> <li>Set data of sub address 07(h) to 10 (h), 11 (h), 12 (h). Measure DC offset of TP12, TP13 and TP16 (ΔV<sub>M W</sub> mV, ΔV<sub>M R</sub> mV, ΔV<sub>M L</sub> mV).</li> </ul>

Note	Test Condition											
	Input Point	Meas. Point	Bus Data (hexadecimal)								SW1	
			00	01	02	03	04	05	06	07		
26	TP6 TP8	TP13 TP16	40	40	72	00	72	40	07	10	(a)	<ul style="list-style-type: none"> <li>Connect TP6 and TP8 to GND.</li> <li>Change data of sub address 06 (h) to 07 (h), 47 (h), 87 (h), and C7 (h). Measure DC offset of TP13 and TP16 (<math>\Delta V_S R</math> mV, <math>\Delta V_S L</math> mV).</li> </ul>
27	TP6 TP8	TP13 TP16	40	40	72	00	72	40	C0	10 / 11 / 12	(a)	<ul style="list-style-type: none"> <li>Input signal (1 kHz, 500 mV<sub>rms</sub>, sine wave) to TP6 and TP8.</li> <li>Set data of sub address 07 (h) to 10 (h).</li> <li>Measure amplitude of TP13 and TP16 (v13<sub>0</sub> mV<sub>rms</sub>, v16<sub>0</sub> mV<sub>rms</sub>).</li> <li>Set data of sub address 07 (h) to 11 (h).</li> <li>Measure amplitude of TP13 and TP16 (v13<sub>MUT</sub> mV<sub>rms</sub>, v16<sub>MUT</sub> mV<sub>rms</sub>).</li> <li><math>G_{MUT} RdB = 20\log(v13_{MUT}/v13_0)</math> <math>G_{MUT} LdB = 20\log(v16_{MUT}/v16_0)</math></li> <li>Input signal (80 Hz, 100 mV<sub>rms</sub>, sine wave) to TP6 and TP8.</li> <li>Set data of sub address 07 (h) to 10 (h).</li> <li>Measure amplitude of TP12 (v12<sub>0</sub> mV<sub>rms</sub>)</li> <li>Set data of sub address 07 (h) to 12 (h).</li> <li>Measure amplitude of TP12 (v12<sub>MUT</sub> mV<sub>rms</sub>).</li> <li><math>G_{MUT} WdB = 20\log(v12_{MUT}/v12_0)</math></li> </ul>

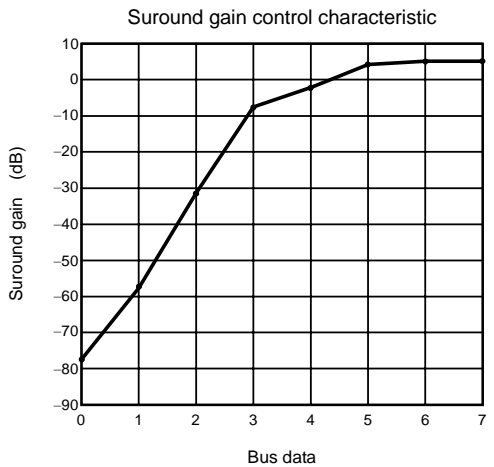
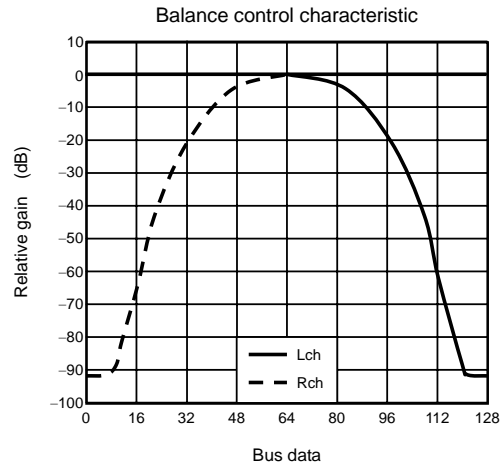
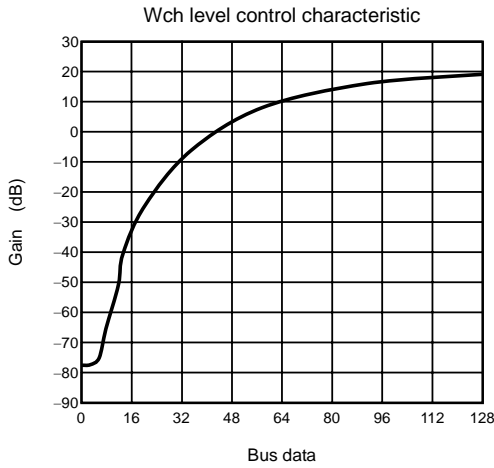
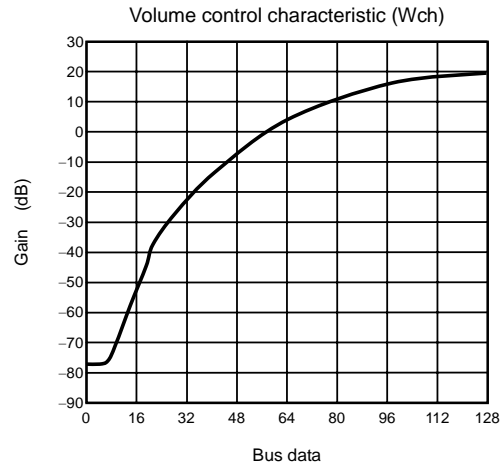
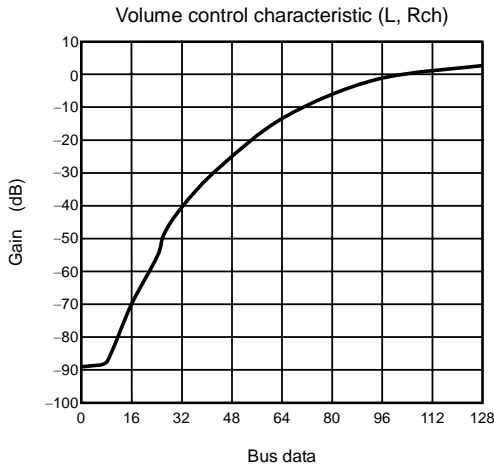

Tone control characteristics

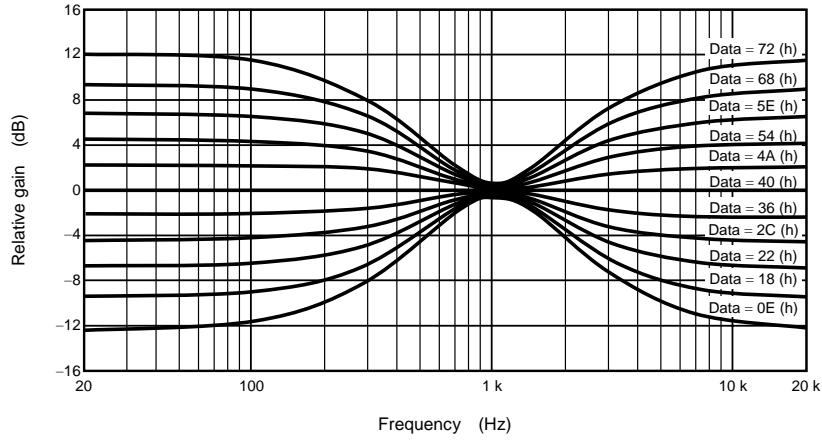

Surround frequency characteristic (gain)

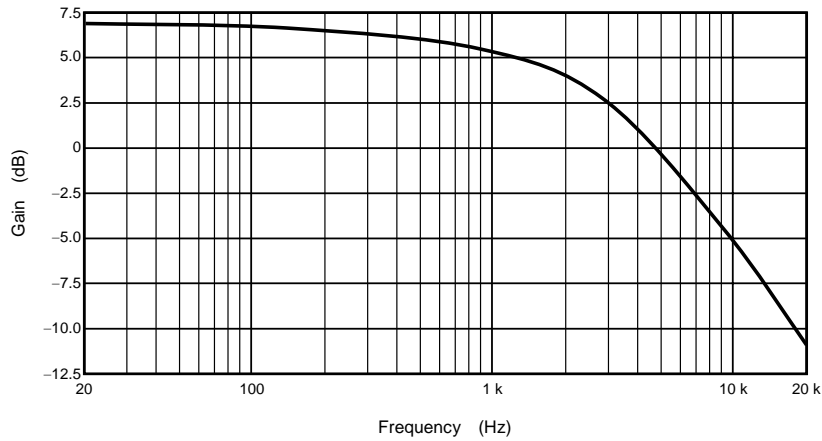

Surround frequency characteristic (phase)/Mode 4  $\phi$

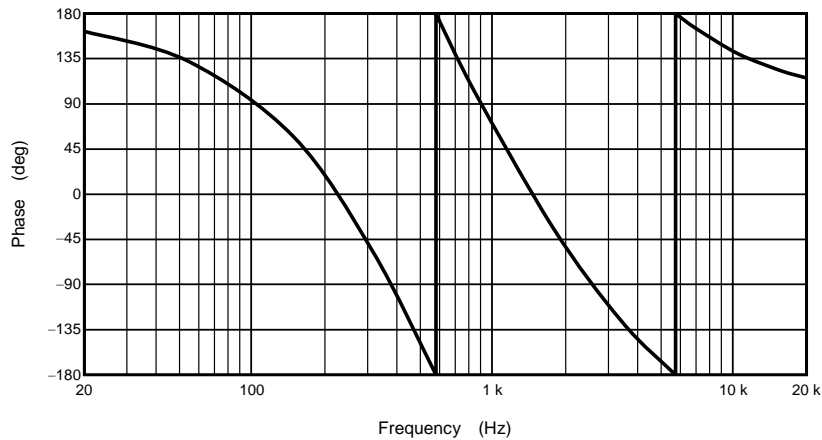

## Test Circuit 1

### DC Characteristics

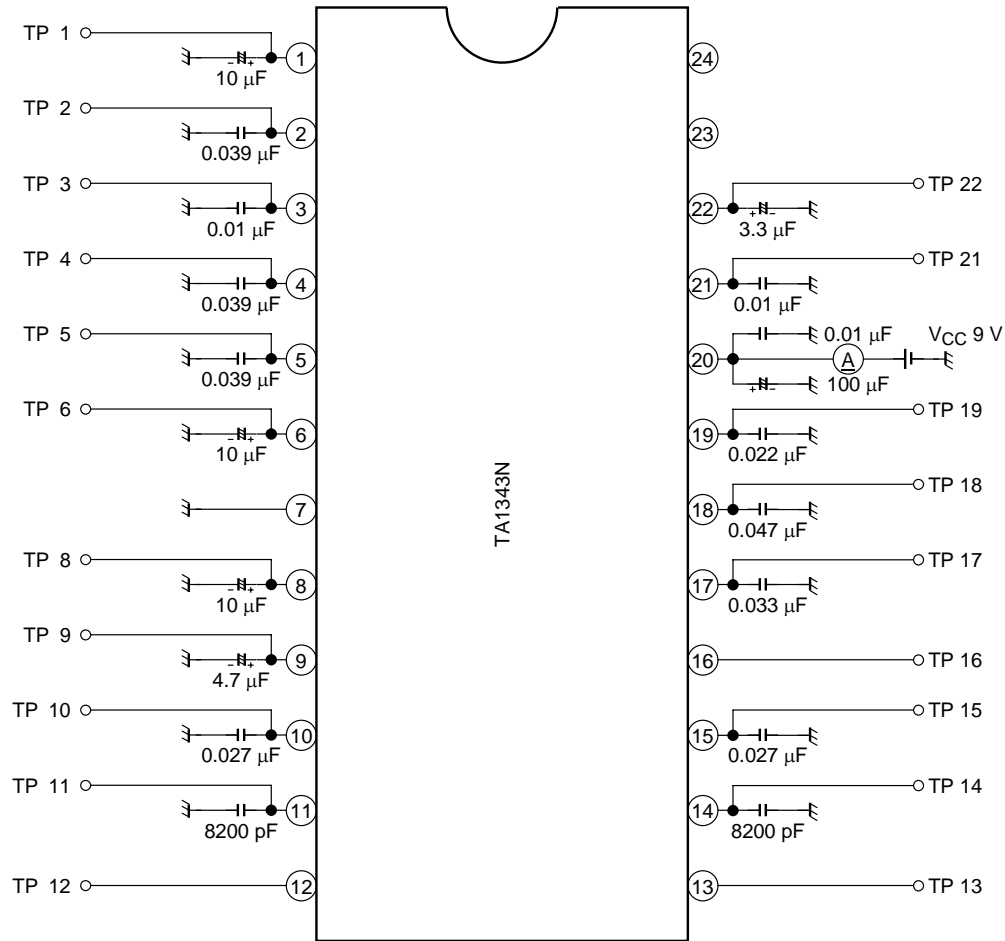

**Test Circuit 2**

**AC Characteristics**

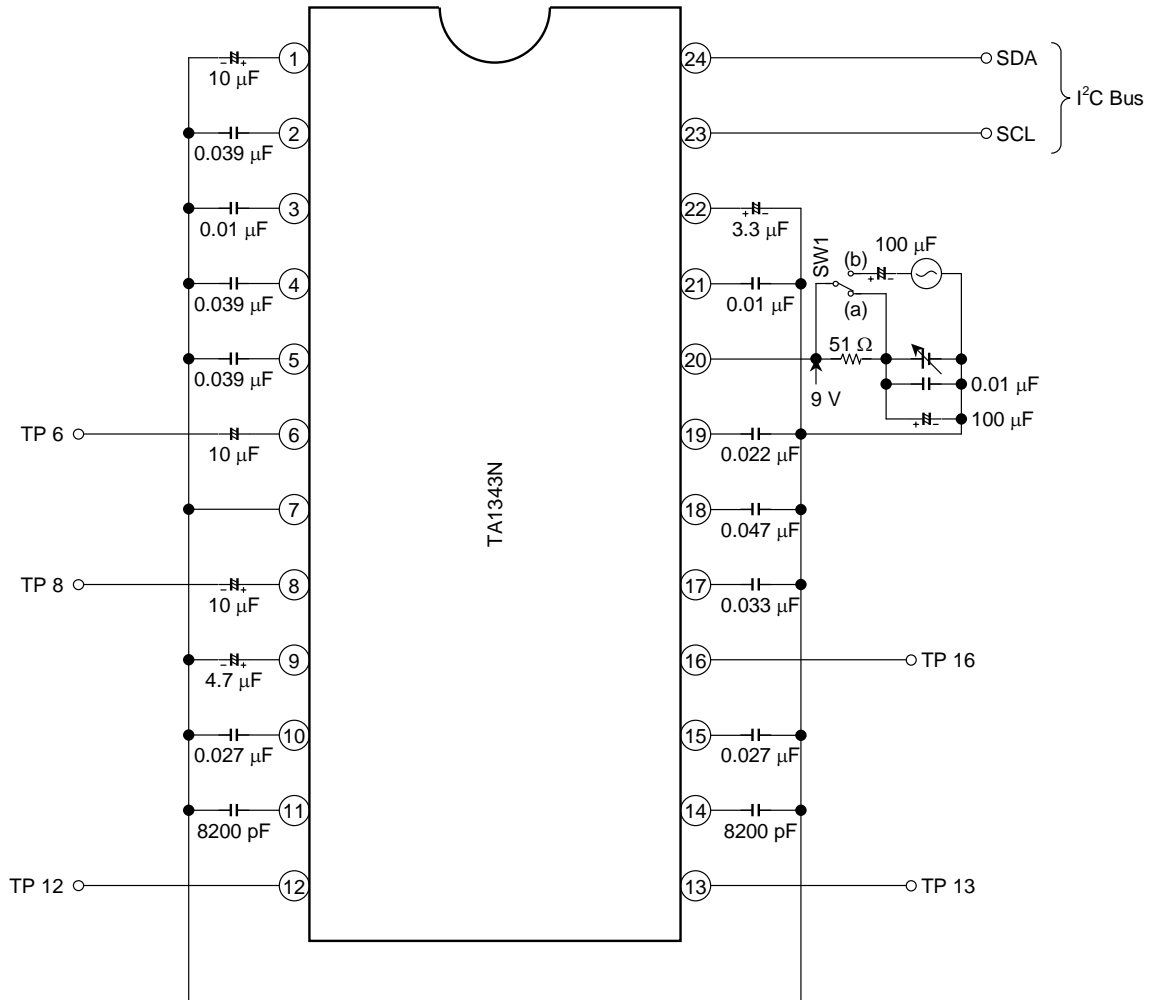

## Application Circuit

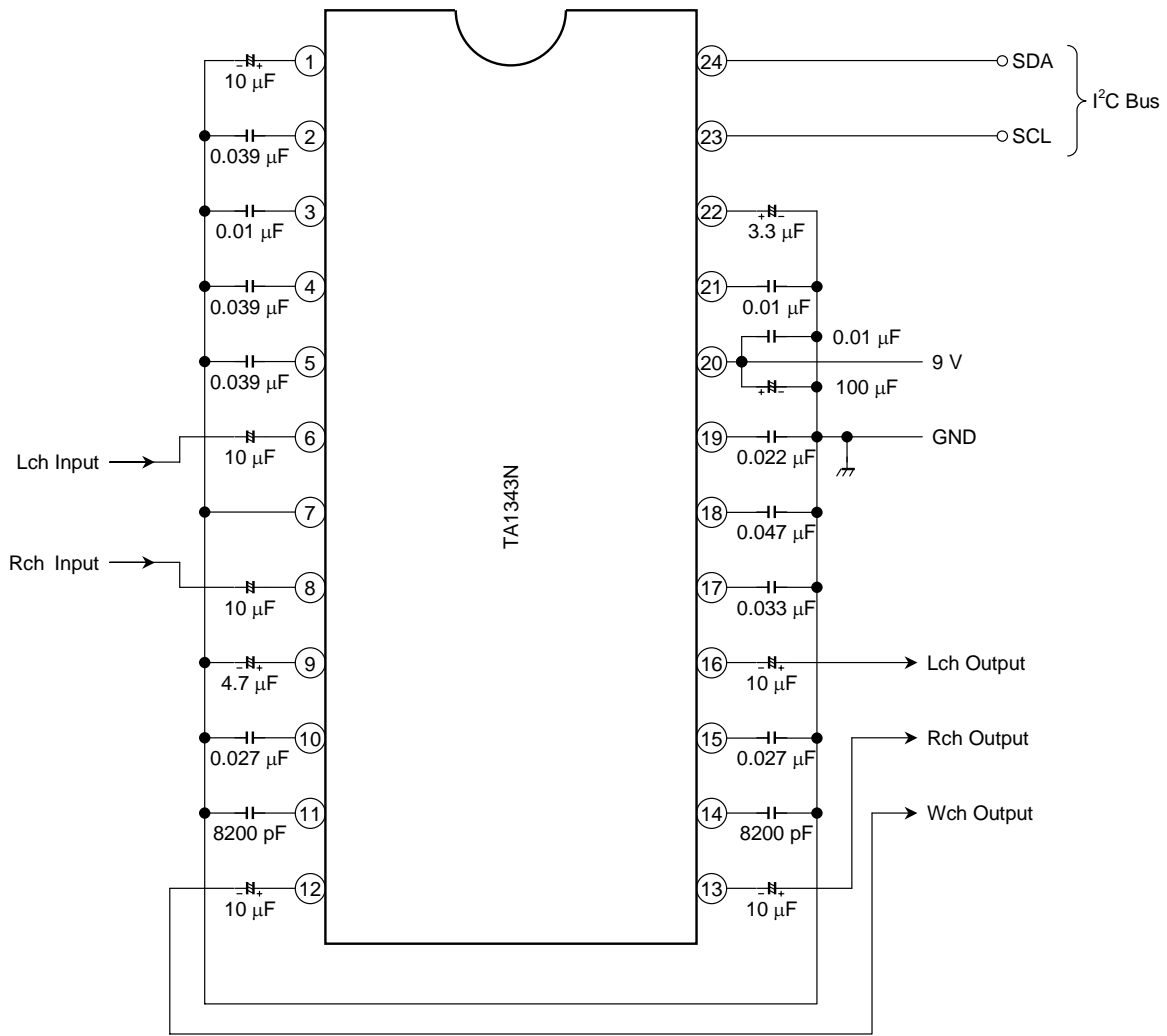



## Package Dimensions

SDIP24-P-300-1.78

Unit : mm

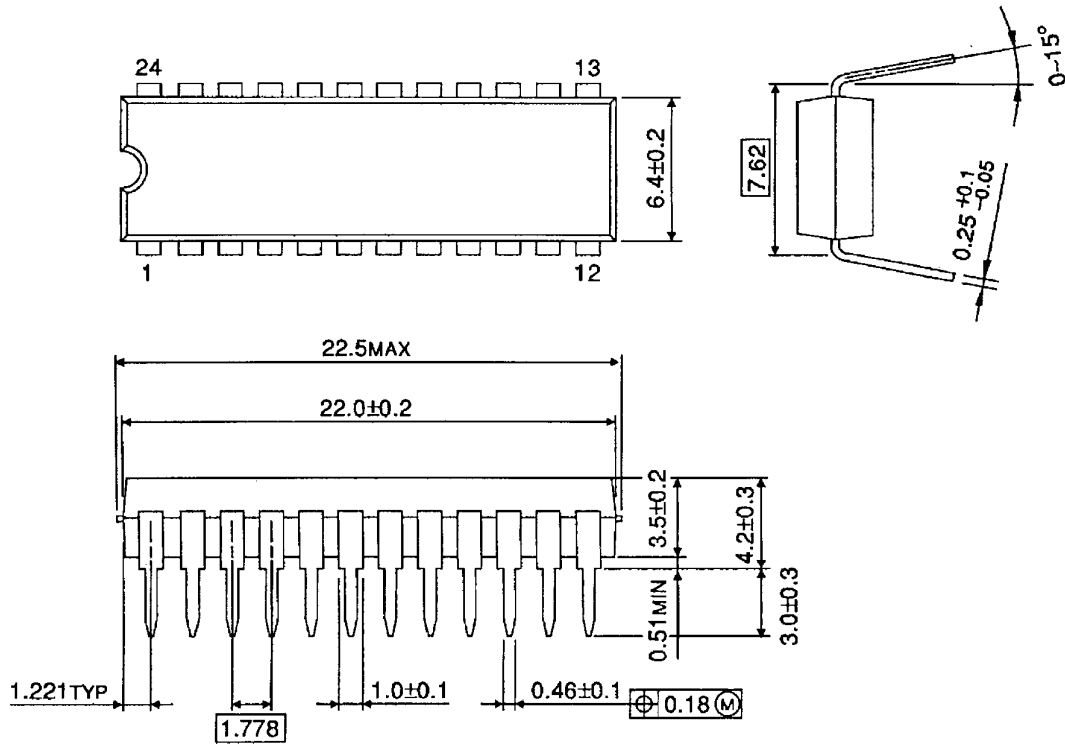

Weight: 1.22 g (typ.)

**RESTRICTIONS ON PRODUCT USE**

000707EBA

- TOSHIBA is continually working to improve the quality and reliability of its products. Nevertheless, semiconductor devices in general can malfunction or fail due to their inherent electrical sensitivity and vulnerability to physical stress. It is the responsibility of the buyer, when utilizing TOSHIBA products, to comply with the standards of safety in making a safe design for the entire system, and to avoid situations in which a malfunction or failure of such TOSHIBA products could cause loss of human life, bodily injury or damage to property.  
In developing your designs, please ensure that TOSHIBA products are used within specified operating ranges as set forth in the most recent TOSHIBA products specifications. Also, please keep in mind the precautions and conditions set forth in the "Handling Guide for Semiconductor Devices," or "TOSHIBA Semiconductor Reliability Handbook" etc..
- The TOSHIBA products listed in this document are intended for usage in general electronics applications (computer, personal equipment, office equipment, measuring equipment, industrial robotics, domestic appliances, etc.). These TOSHIBA products are neither intended nor warranted for usage in equipment that requires extraordinarily high quality and/or reliability or a malfunction or failure of which may cause loss of human life or bodily injury ("Unintended Usage"). Unintended Usage include atomic energy control instruments, airplane or spaceship instruments, transportation instruments, traffic signal instruments, combustion control instruments, medical instruments, all types of safety devices, etc.. Unintended Usage of TOSHIBA products listed in this document shall be made at the customer's own risk.
- The products described in this document are subject to the foreign exchange and foreign trade laws.
- The information contained herein is presented only as a guide for the applications of our products. No responsibility is assumed by TOSHIBA CORPORATION for any infringements of intellectual property or other rights of the third parties which may result from its use. No license is granted by implication or otherwise under any intellectual property or other rights of TOSHIBA CORPORATION or others.
- The information contained herein is subject to change without notice.