

- SONET/SDH Mux/Demux, Transport Overhead Terminating Transceiver and Pointer Processors for STS-48/STM-16 and up to 4 x STS-12/STM-4 or 16 x STS-3/STM-1s.
- Serial STS-12/STM-4 and STS-3/STM-1 interfaces.
- Provisionable as SONET or SDH on a per line basis.
- Provisionable as SOH/LOH pass-through or termination/regeneration device.
- Built-in 192x48 cross-connects for STS-1 level cross-connection or add/drop, in both Mux and Demux directions.
- Compliant with Bellcore GR-253, ITU G.707, and ANSI T1.105 -1995 standards.

Multiplex Direction:

- Supports parallel STS-48/STM-16 or serial 4xSTS-12/STM-4 or serial 16xSTS-3/STM-1 inputs.
- Provides a single STS-48/STM-16 output.
- Pointer Processors for all valid input combinations of STS-48c/AU-4-16c, STS-12c/AU-4-4c, STS-3c/AU-4, or STS-1/AU-3 signals.
- Non-intrusive TOH monitoring for all inputs: STS-48, 4xSTS-12 or 16xSTS-3.
- Provisionable pointer processor bypass available for STS-48 to STS-48 operation (through-timing). Both a full bypass (no frame regeneration) as well as a pointer processor bypass (frame regeneration can be enabled) are provided.

- TOH can be either terminated/regenerated, or transparently passed-through device on a per-function basis, in both through-timing and pointer processor applications.
- For multiplex applications (4xSTS-12 or 16xSTS-3), the TOH for the lower speed tributaries is passed-through in the unused bytes of the outgoing STS-48 signal.
- STS-48 frame regeneration on output side. Provisionable pass-through or regeneration of defined TOH bytes.

Demultiplex Direction:

- Supports a single STS-48/STM-16 input.
- Provides parallel STS-48/STM-16, serial 4xSTS-12/STM-4 or serial 16xSTS-3/STM-1 outputs.
- Pointer Processor for all valid input combinations of STS-48c/AU-4-16c, STS-12c/AU-4-4c, STS-3c/AU4, or STS-1/AU-3 signals.
- Non-intrusive STS-48/STM-16 TOH monitor.
- Provisionable pointer processor bypass available for STS-48 to STS-48 operation (through-timing). Both a full bypass (no frame regeneration) as well as a pointer processor bypass (frame regeneration can be enabled) are provided.
- TOH can be either terminated/regenerated, or transparently passed-through the device on a per-function basis, in both through-timing and pointer processor applications.
- STS-48/STS-12/STS-3 frame regeneration on output side. Provisionable pass-through or regeneration of defined TOH bytes.

Figure 1: Block Diagram

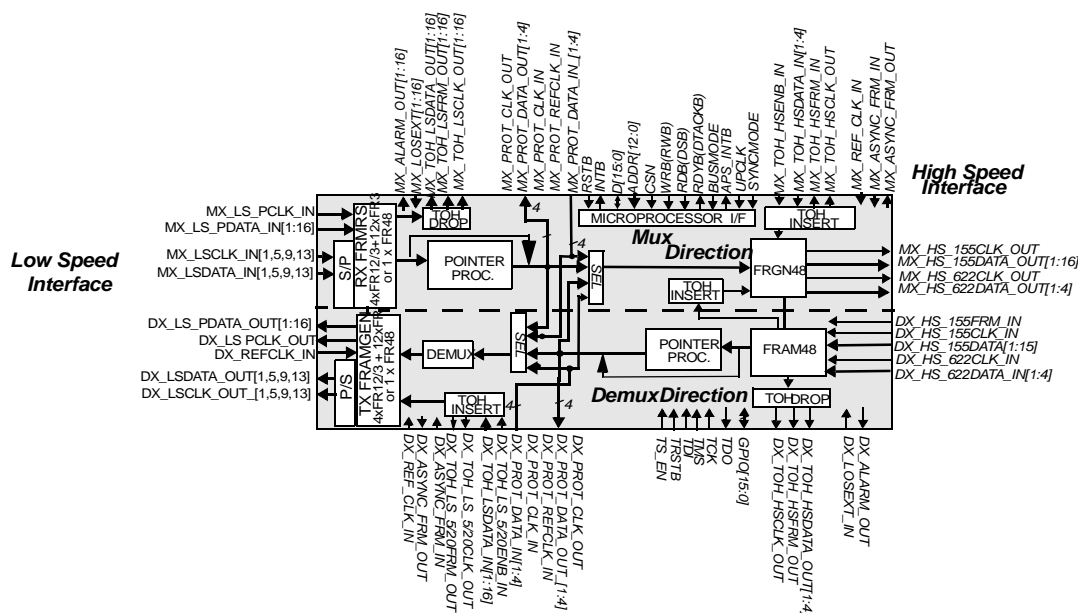

FINAL/PRODUCTION RELEASE Information - The information contained in this document is about a product in fully tested and characterized phase. All features described herein are supported. Contact AMCC for updates to this document and the latest product status.



Overview and Applications

SONET Processing

The S4805 can be used in either SONET or SDH applications. On the low-speed side, it can interface to 4 groups of either 1 STS-12/STM-4 or 4 STS-3/STM-1 signals in each direction.

In the demultiplex direction, the S4805 accepts an STS-48/STM-16 signal, either in 4-bit wide, 622 MHz or 16-bit wide, 155 MHz format. There are then several modes of operation that the S4805 supports in the demultiplex direction.

For STS-48 only operation, the S4805 provides a full-bypass mode, as well as a pointer processor bypass mode. In the full-bypass mode, the S4805 simply passes the incoming STS-48/STM-16 signal directly through to the demux output. Framing, descrambling and TOH monitoring are performed off-line, in a non-intrusive manner for monitoring purposes only. No pointer processing, cross-connection or frame regeneration is performed.

In pointer processor bypass operation, the S4805 locates the incoming STS-48/STM-16 frame, optionally descrambles the data, and non-intrusively monitors the TOH. The STS-48/STM-16 signal is then passed directly to the frame generation block, in which outgoing TOH overhead bytes can be provisionally regenerated, on a per function basis. Again, no pointer processing is performed, and the cross-connect block is bypassed.

For applications requiring pointer processing, the S4805 locates frame in the incoming STS-48/STM-16 signal, performs descrambling, monitors the TOH bytes, and then performs pointer processing. The pointer processor provides a mode in which the incoming TOH bytes transparently pass through the pointer processor to the corresponding locations in the TOH of the outgoing tributaries. The TOH bytes involved in this transparent pass-through mode include the defined overhead bytes for the constituent STS-3/STM-1, STS-12/STM-4 or STS-48/STM-16 signals. A 192x48 cross-connect block is available after the pointer processor. This cross-connect can be used to select STS-1s from any of the demuxed tributaries, tributaries from the low-speed mux inputs, or tributaries from the DX and MX APS interfaces to place into any one of the outgoing STS-1 time slots in any of the outgoing signals in the demux direction. If this signal does not contain a STS-48c/AU-4-16c payload, the S4805 can demultiplex the signal to 4 groups of either 1 STS-12/STM-4 or 4 STS-3/STM-1 tributaries. The selected tributaries then proceed in the demux direction to frame generators that provisionally generate the TOH/SOH bytes, perform scrambling, and output the data. Alternatively, the overhead data can be transparently passed through the frame generation block.

In the multiplex direction, the S4805 accepts a single STS-48/STM-16 signal (4-bits wide, 622 MHz or 16-bit wide, 155 MHz), 4 serial STS-12/STM-4 (622 MHz) signals or 4 groups of 4 serial (155 MHz) STS-3/STM-1 signals. There are several modes of operation that the S4805 supports in the multiplex direction.

For STS-48 only operation, the S4805 provides a full-bypass mode, as well as a pointer processor bypass mode. In the full-bypass mode, the S4805 simply passes the incoming STS-48/STM-16 signal directly through to the mux output. Framing, descrambling and TOH monitoring are performed off-line, in a

non-intrusive manner for monitoring purposes only. No pointer processing, cross-connection or frame regeneration is performed.

In pointer processor bypass operation, the S4805 locates the incoming STS-48/STM-16 frame, optionally descrambles the data, and non-intrusively monitors the TOH. The STS-48/STM-16 signal is then passed directly to the frame generation block, in which outgoing TOH overhead bytes can be provisionally regenerated, on a per function basis. Again, no pointer processing is performed, and the cross-connect block is bypassed.

For applications requiring pointer processing, the S4805 locates the incoming STS-48/STM-16, STS-12/STM-4 or STS-3/STM-1 frames, descrambles the data, non-intrusively monitors the TOH/SOH bytes and then performs pointer processing. The pointer processor provides a mode in which the incoming TOH bytes transparently pass through the pointer processor to the corresponding locations in the TOH of the outgoing tributaries. The TOH bytes involved in this transparent pass-through mode include the defined overhead bytes for the constituent STS-3/STM-1, STS-12/STM-4 or STS-48/STM-16 signals. A 192x48 cross-connect block is available after the pointer processor. This cross-connect can be used to select STS-1s from the incoming multiplex side signals, tributaries from the demux direction, or tributaries from either the DX or MX APS interface. These selected tributaries are then muxed into an STS-48/STM-16 signal. This STS-48/STM-16 muxed signal then proceeds to a frame generator that provisionally generates the TOH/SOH bytes, performs scrambling, and outputs the data. Alternatively, the overhead data can be transparently passed through from the mux inputs to output.

Low-Speed Interfaces

On the low-speed side, in both the mux and demux directions, the S4805 supports either a 16-bit wide, 155 Mb/s STS-48/STM-16 signal, a 4-bit wide, 622 Mb/s STS-48/STM-16 signal, 4 serial STS-12/STM-4 signals operating at 622 Mb/s or 4 groups of 4 serial STS-3/STM-1 signals operating at 155 Mb/s. The S4805 is designed to bolt directly to fiber optic transceivers with built-in clock data recovery. (See figure below.)

High-Speed Interface

On the high-speed side, in both the mux and demux directions, the S4805 supports either a 16-bit wide, 155 Mb/s or a 4-bit wide, 622 Mb/s STS-48/STM-16 signal.

Controller Interface

A high-speed microprocessor interface is provided for configuration and monitoring. S4805 provides numerous automatic monitoring functions. It can be configured to provide an interrupt to the control system, or it can be operated in a polled mode.

Applications:

- SONET/SDH add/drop multiplexers, terminal multiplexers, and digital cross connects.
- WDM/DWDM Mux/Demux applications

Figure 2: Typical Application

Typical Application: S4805 in 2.488 Gb/s SONET/SDH Add/Drop Multiplexer Application

