

TA31180FN

FILTERLESS IF DETECTOR IC FOR CORDLESS TELEPHONE

This IF detector IC includes the external 2nd IF ceramic filter and the external discriminator in itself and that realized to be able to eliminate the external parts extremely.

FEATURES

- No need of the external ceramic filter and discriminator
- Low voltage operation : $V_{CC} = 1.8V \sim 5.5V$
- High sensitivity : 12dB sensitivity $20dB/\mu V$ EMF (50Ω Input)
- Built-in noise detector circuit
- RSSI function
- Small package : SSOP24 pin (0.65mm pitch)

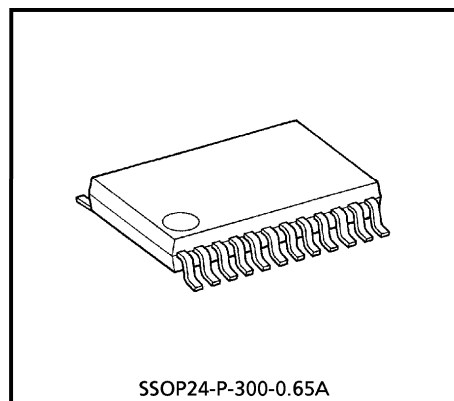

Weight : 0.14g (Typ.)

BLOCK DIAGRAM

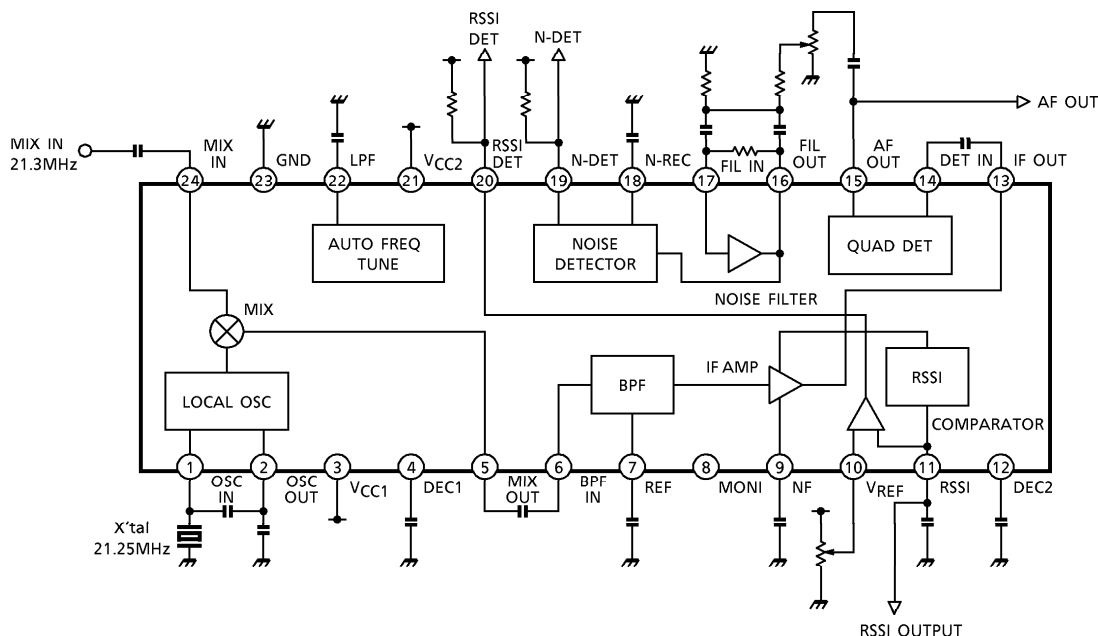

PIN FUNCTION (The values of resistor and capacitor are typ.)

PIN No.	PIN NAME	FUNCTION	INTERNAL EQUIVALENT CIRCUIT
1	OSC IN	LOCAL OSC input/output terminals. Colpitts oscillator is formed by internal emitter follower and external crystal. And external local signal injection is possible from pin 1 or pin 2.	
2	OSC OUT		
3	VCC1	Power supply terminal.	—
4	DEC1	AGC terminal for MIX conversion gain. This terminal connects capacitor to GND.	
5	MIX OUT	MIX Output terminal. Output impedance is around 1.1kΩ.	
6	BPF IN	Internal BPF input terminal.	
7	REF	Internal BPF decoupling terminal for DC bias. This terminal connects capacitor to GND.	
8	MONI	Use at open as this terminal connects to internal circuit.	—

PIN No.	PIN NAME	FUNCTION	INTERNAL EQUIVALENT CIRCUIT
9	NF	IF AMP decoupling terminal for DC bias. This terminal connects capacitor to GND.	
10	VREF	Reference power supply terminal.	
11	RSSI	This terminal outputs DC level according to input signal level to IF AMP. Dynamic range is around 80dB.	
12	DEC2	QUAD DET AFC terminal. This terminal connects to capacitor to GND.	
13	IF OUT	Output terminal of IF AMP.	
14	DET IN	QUAD DET input terminal.	
15	AF OUT	Demodulated output terminal. Output impedance is around 1.1kΩ.	

PIN No.	PIN NAME	FUNCTION	INTERNAL EQUIVALENT CIRCUIT
16	FIL OUT	FIL AMP input/output terminal. Compose the BPF by putting the external capacitance and Resistance and this terminal connects to rectifire circuit internally by internal decoupling capacitance.	
17	FIL IN		
18	N-REC	Rectifire to direct current by external capacitance after amplifying the FIL AMP output to around 20dB.	
19	N-DET	Operating as comparator of N-REC terminal output voltage, and doing the judgement of NOISE DET. Hysteresis width is around 100mV and this terminal is from open collector.	
20	RSSI DET	This terminal outputs the result of comparator between VREF terminal input voltage and RSSI terminal output voltage. If VREF is less than RSSI, then RSSI DET is set to "L". This output is from open collector.	
21	VCC2	Power supply terminal for AUTO FREQ TUNE block.	—
22	LPF	Decoupling terminal of the circuit, that tuning the internal BPF f ₀ automatically. This terminal connects capacitor to GND.	
23	GND	GND terminal.	—
24	MIX IN	1st IF signal input terminal.	

DESCRIPTION

1. BPF (band pass filter)

1st IF from MIX input terminal is converted to 2nd IF 50kHz by mixing 2nd MIX and LOCAL OSC 21.250MHz to be input to BPF.

This BPF is of high Q with center frequency $f_0 = 50\text{kHz}$, -3dB band width $BW = 8\text{kHz}$ and attenuation 57dB and these factors are cause of selectivity characteristics and demodulation output distortion characteristics.

This IC is of automatic frequency tuning system that stabilize the center frequency f_0 drift of internal BPF for 2nd IF by temprature and parameter tolerance and this function is executed by control circuit with internal clock as reference frequency from LOCAL OSC. Clock frequency signal source should be required high accuracy for 2nd local frequency as the signal source of referency clock 21.250MHz, because selectivity characteristics and demodulation output distortion characteristics depend on clock frequency.

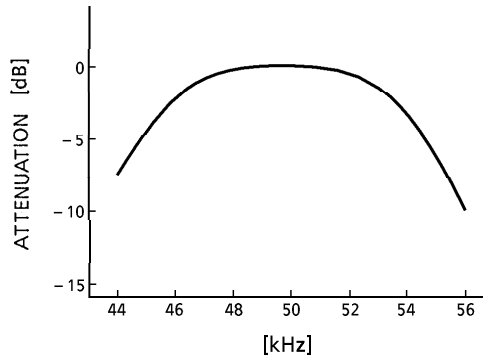

Fig.1 BPF characteristics

2. LOCAL OSC external injection method

Inputting from pin1 as shown in Fig.2, add resistor R21 to pin2 and set the input signal so that signal level at pin1 is $95\sim 105\text{dB}\mu\text{V}$. A built-in BUFFER amp minimizes leakage from MIX.

Inputting from pin2 as shown in Fig.3, set the injection level at pin2 between $95\text{dB}\mu\text{V}$ and $105\text{dB}\mu\text{V}$.

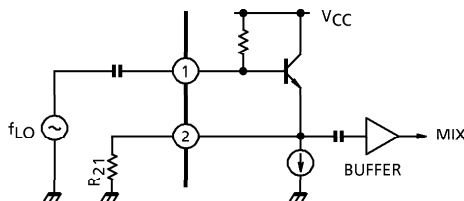

Fig.2

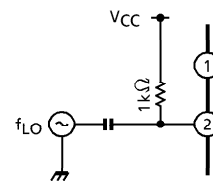

Fig.3

3. NOISE FILTER AMP

NOISE FILTER AMP can construct BPF as Fig.4. Setting constants follow as below equation (1)~(3).

$$(1) \quad f_0 = \frac{1}{2\pi \sqrt{R_1 (R_2 // R_3) C^2}}$$

$$(2) \quad G_V = R_1 / 2R_2$$

$$(3) \quad Q^2 = \frac{R_3}{4 (R_2 // R_3)}$$

at $R_2 \gg R_p$

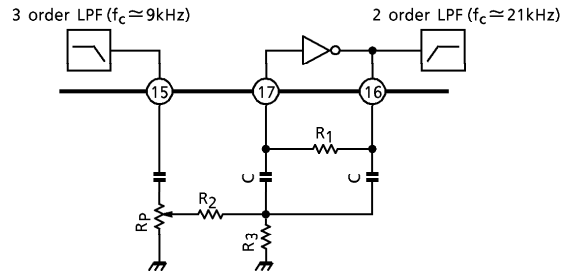

Fig.4

In case of the setting level of NOISE DET being low, NOISE DET may operate incorrectly in the cause of carrier leak components of IF frequency 50kHz.

In this case get the NOISE DET filter set to LPF to be able to eliminate carrier leak components.

$$(1) \quad f_0 = \frac{1}{2\pi R \sqrt{C_1 C_2}}$$

$$(2) \quad G_V = \frac{1}{2\omega C_2 R_4}$$

$$(3) \quad Q^2 = \frac{C_1}{4C_2}$$

at $R_4 \gg R$, $\omega = 2\pi f$

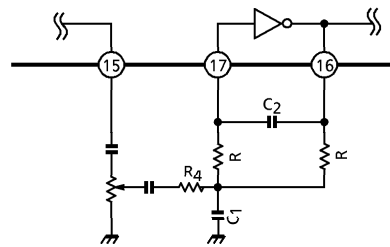

Fig.5

4. Noise detection rise time

The rise time is a proportion of time constant 7.5ms of the smoothing capacitor $C_{181} = 0.1\mu F$ of the noise rectifier and internal resistor $75k\Omega$. Although decreasing the capacitance of C_{181} can shorten the rise time, note that the NOISE DET output fluctuation may increase. This should be taken into account before use.

5. RSSI COMPARATOR

The result of RSSI COMPARATOR is output to RSSI DET (20pin) by comparing RSSI terminal output voltage with V_{REF} terminal input voltage.

Hysteresis range is around 30mV. When $V_{RSSI} > V_{REF}$, RSSI DET is "L" level.

Reference voltage V_{REF} can be set by the external resistance R_{101} .

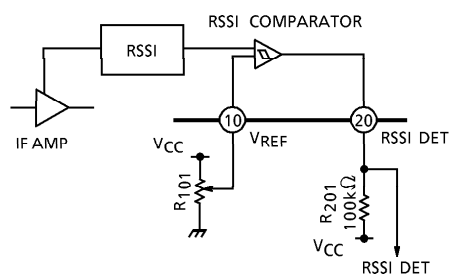

Fig.6

MAXIMUM RATINGS (Ta = 25°C)

CHARACTERISTIC	SYMBOL	RATING	UNIT
Supply Voltage	V _{CC}	7	V
Power Dissipation	P _D	780	mW
Operating Temperature	T _{opr}	-20~+70	°C
Storage Temperature	T _{stg}	-55~+150	°C

ELECTRICAL CHARACTERISTICS (Unless otherwise specified V_{CC} = 2.0V, f_{IN} = 21.30MHz, Δf = ±1.5kHz, f_{MOD} = 1kHz, Ta = 25°C)

CHARACTERISTIC	SYMBOL	TEST CIRCUIT	TEST CONDITION	MIN.	TYP.	MAX.	UNIT
Power Supply Voltage	V _{CC}	—	—	1.8	2.0	5.5	V
Current Consumption	I _{CC}	1	No Signal	4.3	6.7	9.0	mA
MIX Operating Frequency	f _{IN}	—	—	—	21.30	—	MHz
MIX Image Rejection Ratio	I _{RR}	1	V _{IN} = 70dB _μ VEMF, Pin4 GND	20	35	—	dB
MIX Conversion Gain	G _{VC}	1	V _{IN} = 60dB _μ V, Pin4 GND	26	29.5	—	dB
MIX Intercept Point	I _p	—	—	—	103	—	dB _μ VEMF
MIX Input Impedance	R _{IN}	—	—	—	5	—	kΩ
	C _{IN}	—	—	—	3	—	pF
12dB Sensitivity	12dB SN	—	—	—	20	—	dB _μ VEMF
Demodulation Output Level	V _{OD}	1	V _{IN} = 80dB _μ VEMF	110	140	170	mV _{rms}
SN Ratio	SN	1	V _{IN} = 80dB _μ VEMF	40	54	—	dB
AM Rejection Ratio	AMR	—	AM = 30%, V _{IN} = 80dB _μ VEMF	—	38	—	dB
Demodulation Output Distortion	THD	1	V _{IN} = 80dB _μ VEMF	—	-35	-30	dB
Demodulation Output Cut-off Frequency	f _C	—	-3dB	—	3	—	kHz
Pass Band Width	BW	1	-3dB	6	8	—	kHz
Rejection Level at Adjacent Channel	ATTADJ	1	f _{SEP} = ±12.5kHz, f _{MOD} = 400Hz	50	57	—	dB
LOCAL OSC Input Level	V _{LO}	—	—	95	100	105	dB _μ V

ELECTRICAL CHARACTERISTICS (Unless otherwise specified $V_{CC} = 2.0V$, $f_{IN} = 21.30MHz$, $\Delta f = \pm 1.5kHz$,
 $f_{MOD} = 1kHz$, $T_a = 25^\circ C$)

CHARACTERISTIC	SYMBOL	TEST CIR-CUIT	TEST CONDITION	MIN.	TYP.	MAX.	UNIT
RSSI Output Voltage	V_{RSSI1}	1	$V_{CC} = 3V$, $V_{IN} = 20dB_{\mu}VEMF$	0.3	0.6	0.9	V
	V_{RSSI2}		$V_{CC} = 3V$, $V_{IN} = 90dB_{\mu}VEMF$	1.8	2.2	2.6	V
RSSI COMPARATOR Reference Input Range	V_{REF}	—	—	0.3	—	$V_{CC} - 1$	V
RSSI COMPARATOR Hysteresis Width	V_{HYS}	—	—	—	30	—	mV
RSSI COMPARATOR Output Voltage	V_{RDET}	1	$I_{SINK} = 0.2mA$	—	0.1	0.5	V
RSSI COMPARATOR Output Leak Current	I_{RLEAK}	1	$V_{RDET} = V_{CC}$, $V_{RSSI} > V_{REF}$	—	0	5	μA
NOISE DET Output Voltage	V_{NDET}	1	$I_{SINK} = 0.2mA$	—	0.1	0.5	V
NOISE DET Output Leak Current	I_{NLEAK}	1	$V_{NDET} = V_{CC}$	—	0	5	μA
Noise Comparator Detect Level	V_{TH-H}	1	—	—	0.5	0.7	V
	V_{TH-L}		—	0.3	0.4	—	V

TEST CIRCUIT 1

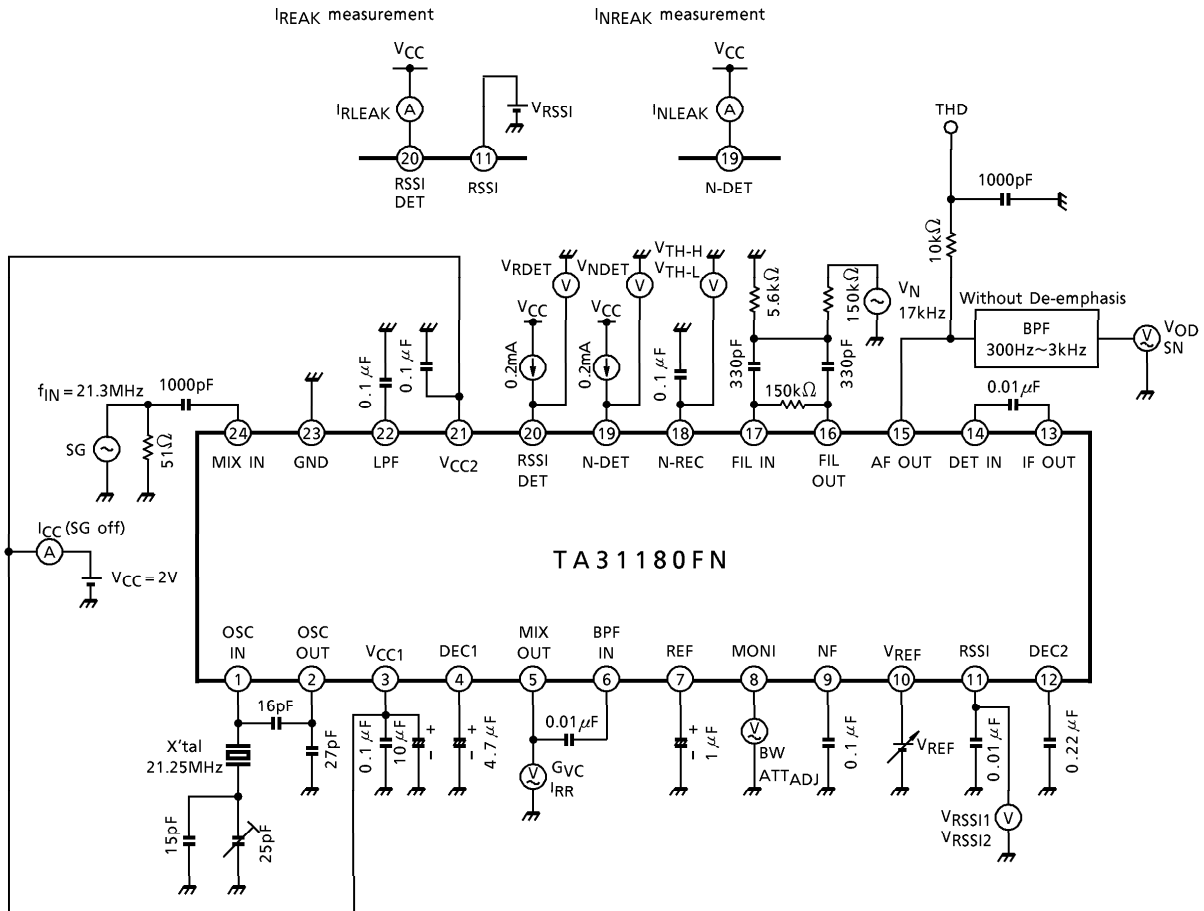

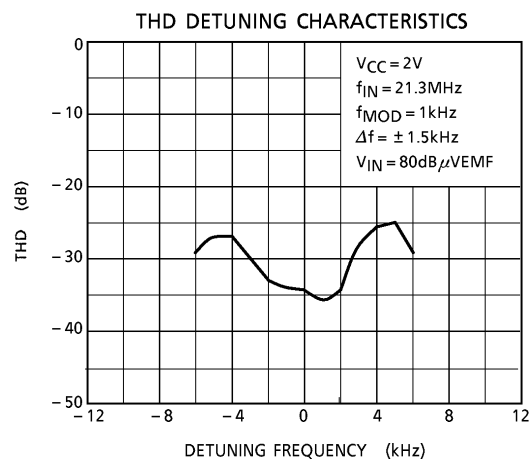
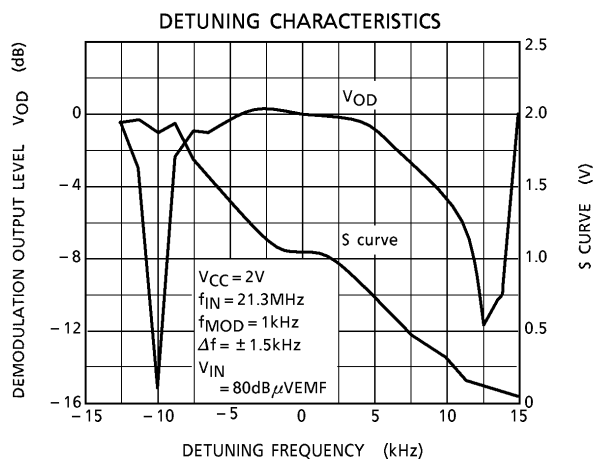
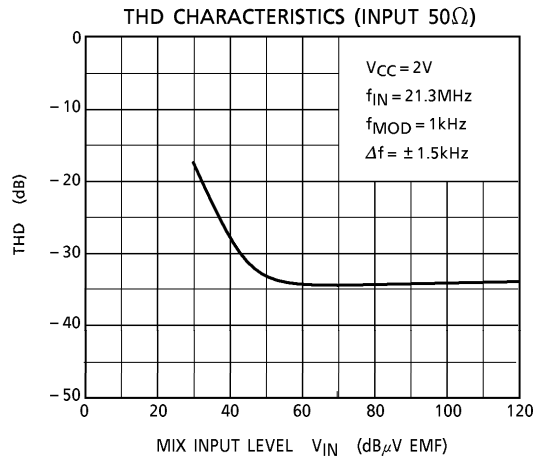
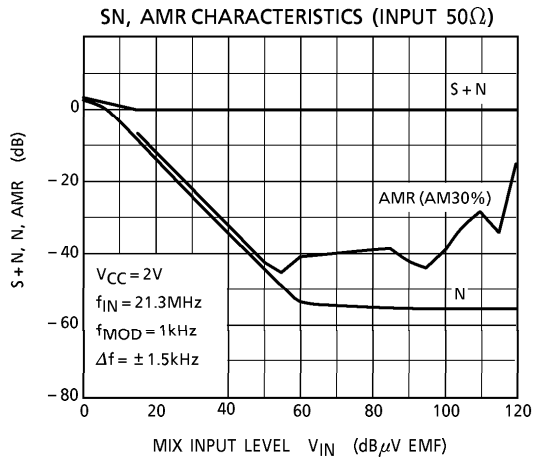
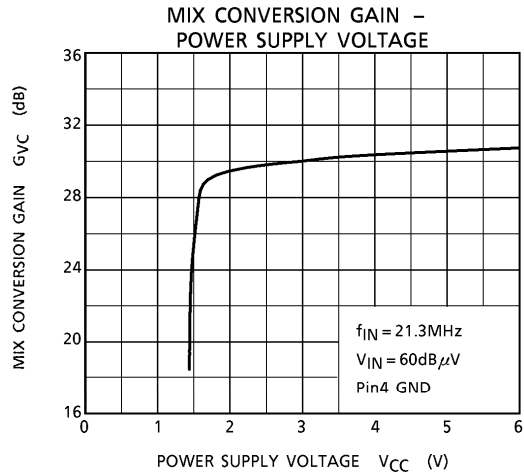
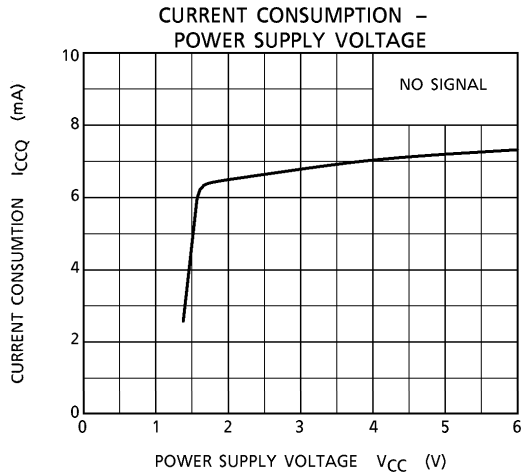

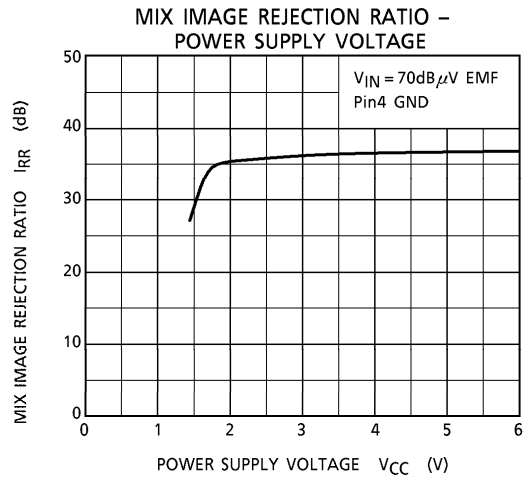
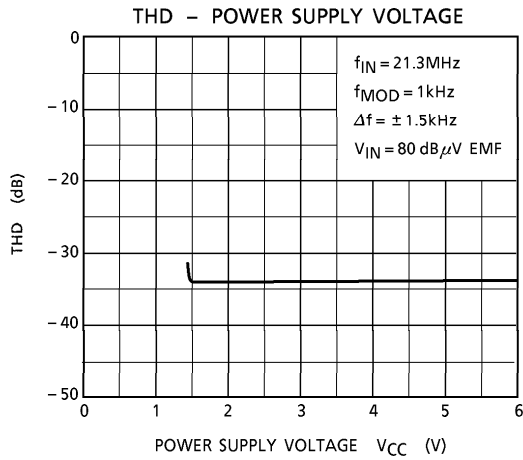
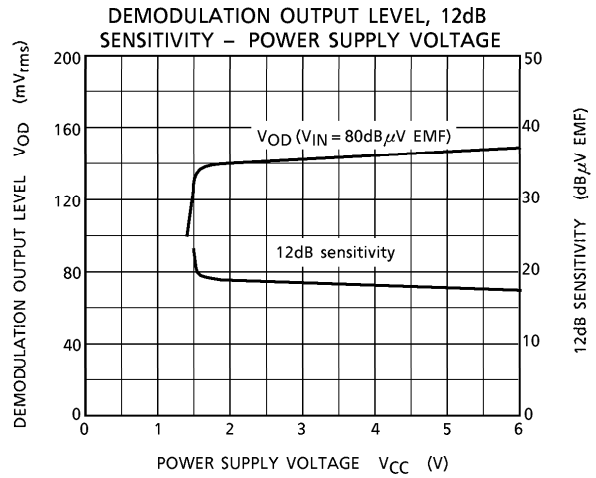
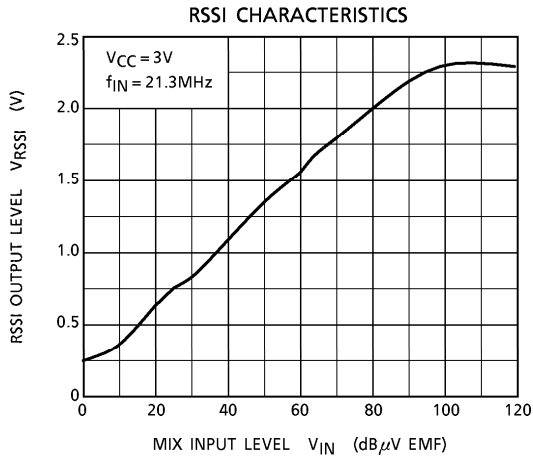

APPLICATION CIRCUIT

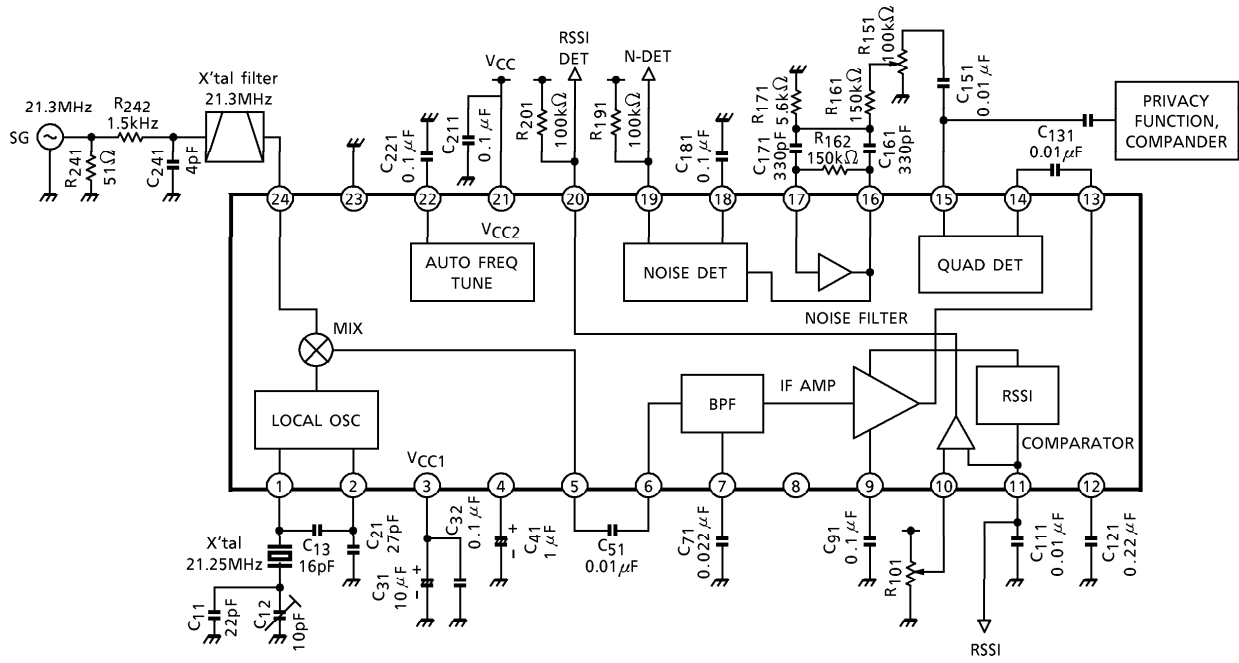

PACKAGE DIMENSIONS
SSOP24-P-300-0.65A

UNIT : mm

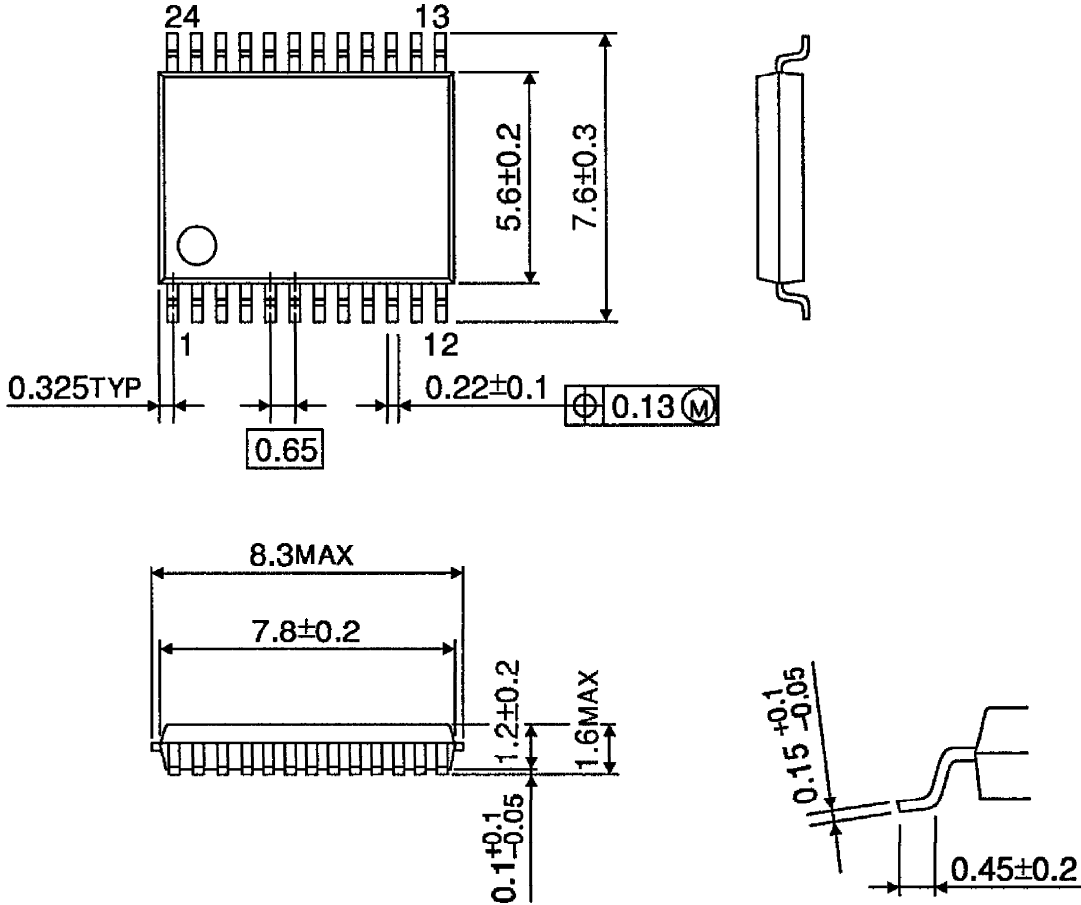

Weight : 0.14g (Typ.)

RESTRICTIONS ON PRODUCT USE

000707EBA

- TOSHIBA is continually working to improve the quality and reliability of its products. Nevertheless, semiconductor devices in general can malfunction or fail due to their inherent electrical sensitivity and vulnerability to physical stress. It is the responsibility of the buyer, when utilizing TOSHIBA products, to comply with the standards of safety in making a safe design for the entire system, and to avoid situations in which a malfunction or failure of such TOSHIBA products could cause loss of human life, bodily injury or damage to property. In developing your designs, please ensure that TOSHIBA products are used within specified operating ranges as set forth in the most recent TOSHIBA products specifications. Also, please keep in mind the precautions and conditions set forth in the "Handling Guide for Semiconductor Devices," or "TOSHIBA Semiconductor Reliability Handbook" etc..
- The TOSHIBA products listed in this document are intended for usage in general electronics applications (computer, personal equipment, office equipment, measuring equipment, industrial robotics, domestic appliances, etc.). These TOSHIBA products are neither intended nor warranted for usage in equipment that requires extraordinarily high quality and/or reliability or a malfunction or failure of which may cause loss of human life or bodily injury ("Unintended Usage"). Unintended Usage include atomic energy control instruments, airplane or spaceship instruments, transportation instruments, traffic signal instruments, combustion control instruments, medical instruments, all types of safety devices, etc.. Unintended Usage of TOSHIBA products listed in this document shall be made at the customer's own risk.
- The products described in this document are subject to the foreign exchange and foreign trade laws.
- The information contained herein is presented only as a guide for the applications of our products. No responsibility is assumed by TOSHIBA CORPORATION for any infringements of intellectual property or other rights of the third parties which may result from its use. No license is granted by implication or otherwise under any intellectual property or other rights of TOSHIBA CORPORATION or others.
- The information contained herein is subject to change without notice.