

2.2 Hands-Free Add-On Circuit (HAC) with Controlled Loudhearing

PSB 45030
PSB 45030-T

Bipolar IC

Features

- Low voltage operation (min. 3.0 V) for line powered applications
- Low quiescent current consumption
- On-chip supply and reference voltage regulation
- Two switchable microphone amplifiers with different gains
- Two separate adjustable gain ranges for hands-free and loudhearing operation
- Speaker bridge amplifier with limiter combined with volume control affecting the gain range
- Idle mode for improved sensitivity
- Built-in hysteresis in the transmit/receive comparator preventing uncontrolled switching of the system at low signal level operation

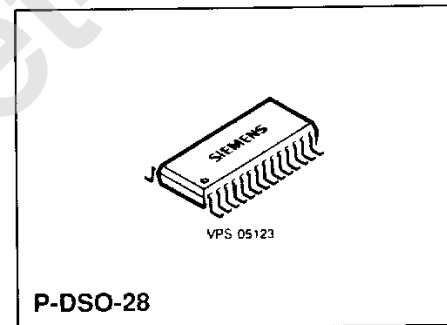
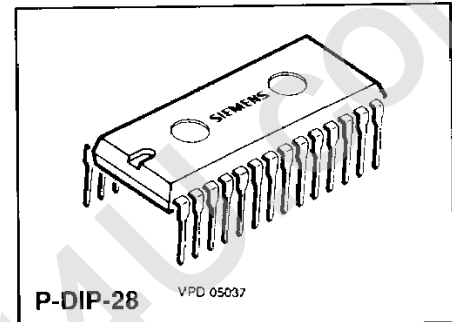

Type	Version	Ordering Code	Package
PSB 45030	V 1.2	Q67000-A6020	P-DIP-28
PSB 45030-T	V 1.2	Q67000-A6015	P-DSO-28 (SMD)

The PSB 45030 is an IC for voice switched hands-free and loudhearing telephone applications. All necessary amplifiers, detectors, switches and controllers are on chip. The transmitting path is equipped with two switchable microphone amplifiers, one with differential inputs and one single ended (each with its own adjustable gain range), a common microphone MUTE function, a burst detection system, an output amplifier and a transmit level detector. The receiving channel includes a controlled preamplifier, a receiving level detector and a loudspeaker bridge amplifier. The loudspeaker amplifier includes a power down function and a limiter circuit combined with the volume control. With the attenuation control circuit and the built in reference and supply voltage regulator this IC fits in high performance hands-free, loudhearing and standard hand set operating applications.

The PSB 45030 is preferred to operate in connection with the PSB 4506, 4506A, but it is also able to operate with any other speech circuit with power supply.

Figure 1
Pin Configuration
(top view)

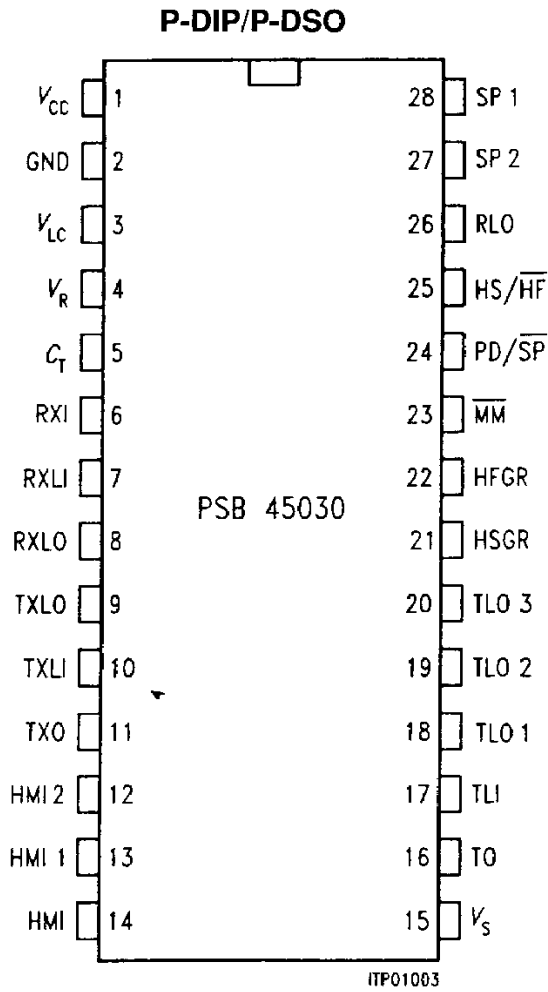

Pin Definitions and Functions

Pin No.	Symbol	Input (I) Output (O)	Function
1	V _{CC}	I	Power supply terminal
2	GND	I	Ground
3	V _{LC}	I	Speaker volume control input
4	V _R	O	Reference voltage output
5	C _T	O	Transient suppression
6	RXI	I	Receive amplifier input
7	RXLI	I	Receive level detector input
8	RXLO	O	Receive level detector output
9	TXLO	O	Transmit level detector output
10	TXLI	I	Transmit level detector input
11	TXO	O	Transmit amplifier output
12	HMI2	I	Handset microphone amplifier inputs
13	HMI1	I	
14	FMI	I	Hands-free microphone amplifier inputs
15	V _S	O	Regulated supply voltage
16	TO	O	Microphone ampl. output for burst detection
17	TLI	I	Burst detector input
18	TLO1	O	Level detector time constant
19	TLO2	O	Level hold time constant
20	TLO3	O	Transmit time constant
21	HSGR	I	Handset gain range adjustment (loudhearing mode)
22	HFGR	I	Hands-free gain range adjustment (hands-free mode)
23	MM	I	Common microphone MUTE input
24	PD/SP	I	Speaker power down
25	HS/HF	I	Handset hands-free switch
26	RLO	O	Automatic level control time constant
27	SP2	O	Outputs of the speaker bridge amplifier
28	SP1	O	

Figure 2
Block Diagram

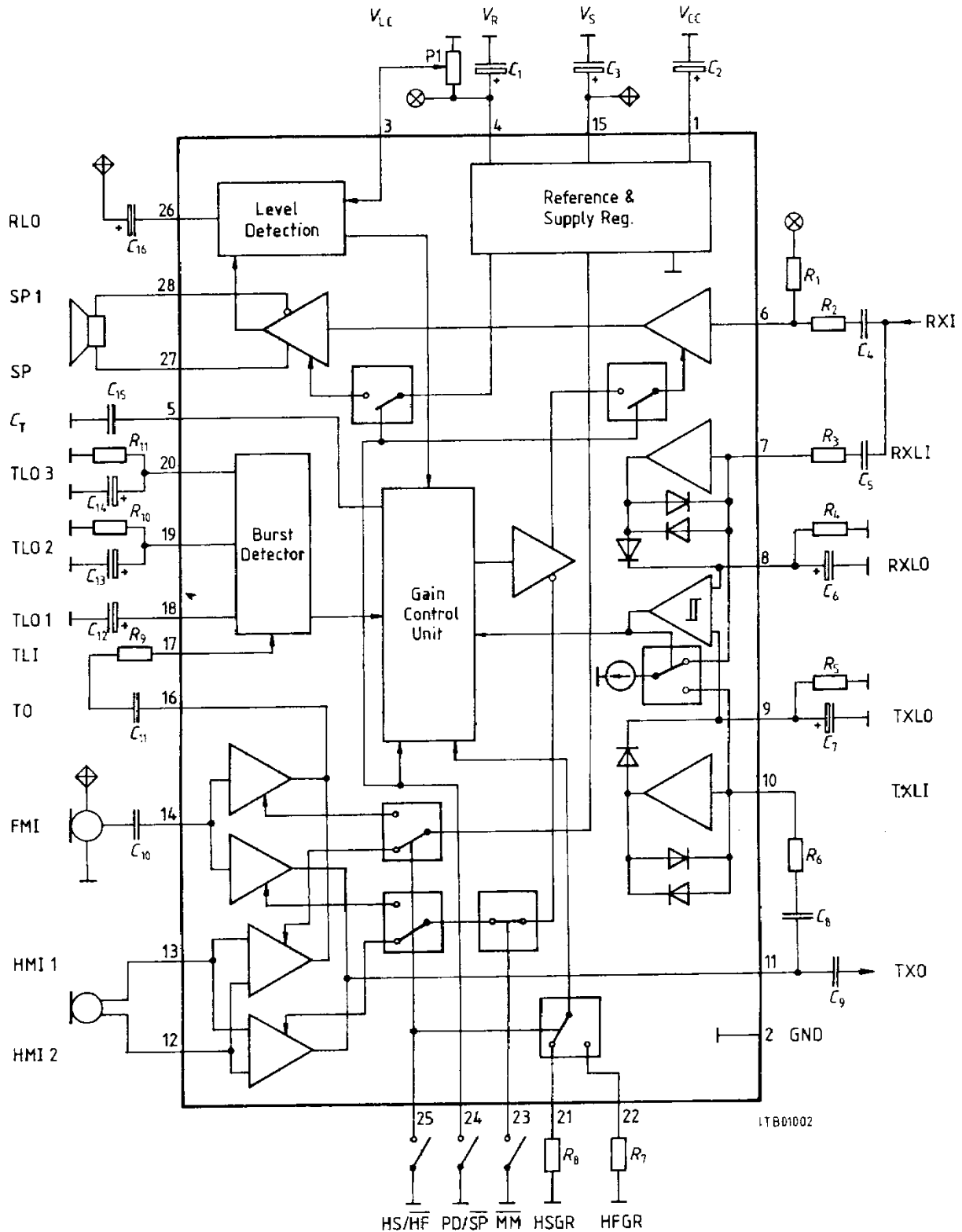

Functional Description of the Block Diagram of the PSB 45030

The PSB 45030 consists of the following functional blocks:

- the reference and supply voltage regulator
- the receive block
- the transmit block
- the level detectors
- the burst detection block
- the gain control block

The reference and supply voltage regulator feeds the circuit itself and delivers two constant voltages V_R and V_S for supplying e. g. a volume control potentiometer, an electret microphone and other peripheral circuitry.

In the receive block the incoming receiving signal will be amplified (to drive a speaker) with a certain adjustable factor depending on the actual state of the circuit and the set volume control value.

The transmit block amplifies the signal of either the handset- or hands-free microphone by a certain adjustable factor depending on the actual state of the circuit and the set volume control value.

The level detector has to envelope the signals in the transmit and receive direction. Due to the large dynamic range of speech, envelope detection is realized logarithmically.

A burst detection block is incorporated directly after the microphone amplifiers deciding whether speech or only background noise is present at the microphone.

The gain control block has to set the gains in transmit and receive direction for every state of the circuit.

List of External Components

Component	Note	Typ. Value
R_1	Receive input signal divider	1 k Ω^*
R_2	Receive input signal divider	5 k Ω^*
R_3	Receive level detector input current adjustment	27 k Ω^*
R_4	Receive level detector decay time adjustment	1 M Ω
R_5	Transmit level detector decay time adjustment	1 M Ω
R_6	Transmit level detector input current adjustment	1 k Ω^*
R_7	Hands-free attenuation range adjustment	10 k Ω^*
R_8	Loudhearing attenuation range adjustment	20 k Ω^*
R_9	Burst detector input current adjustment	5 k Ω^*
R_{10}	Microphone signal hold time constant	220 k Ω
R_{11}	Transmit time constant	220 k Ω
P_1	Volume control adjustment	20 k Ω
C_1	Reference voltage noise filter	1 μ F
C_2	V_{CC} filter capacitor	470 μ F
C_3	Internal supply noise filter	10 μ F
C_4	Receive input signal decoupling capacitor	10 nF*
C_5	Receive level detector input decoupling capacitor	22 nF*
C_6	Receive level detector attack- and decay time constant	1 μ F
C_7	Transmit level detector attack- and decay time constant	1 μ F
C_8	Transmit level detector input signal decoupling capacitor	150 nF*
C_9	Transmit signal decoupling capacitor	33 nF*
C_{10}	Hands-free microphone signal decoupling capacitor	47 nF*
C_{11}	Microphone signal decoupling capacitor	47 nF*
C_{12}	Microphone signal detector time constant	5 μ F
C_{13}	Microphone signal hold time constant	22 μ F
C_{14}	Transmit time constant	1 μ F
C_{15}	Transient suppression capacitor	22 nF
C_{16}	Automatic volume control and limiting time constant	22 μ F

* Depending on electrical, acoustical and filter characteristics

Circuit Description

Power Supply V_{CC} (1)

The supply voltage is 3.0 to 10 V. The required current depends on the available loudspeaker output power and is shown in **figure 3** for various power levels into a 50 Ω speaker. The current consumption for an operation without speaker (e.g. the normal telephone handset operation), when the IC is set into the 'power down' mode (PD/ \overline{SP} pin open or high), is shown in **figure 4**.

The best solution for supplying the PSB 45030 in high performance telephone applications is to connect it to the speech circuit PSB 4506, 4506A.

To ensure a good AC decoupling in the IC, caused by varying current in the speaker amplifier, a filter capacitor of min. 100 μF close to the IC is necessary.

Figure 3

Supply Current versus Supply Voltage versus Output Power (50 Ω)

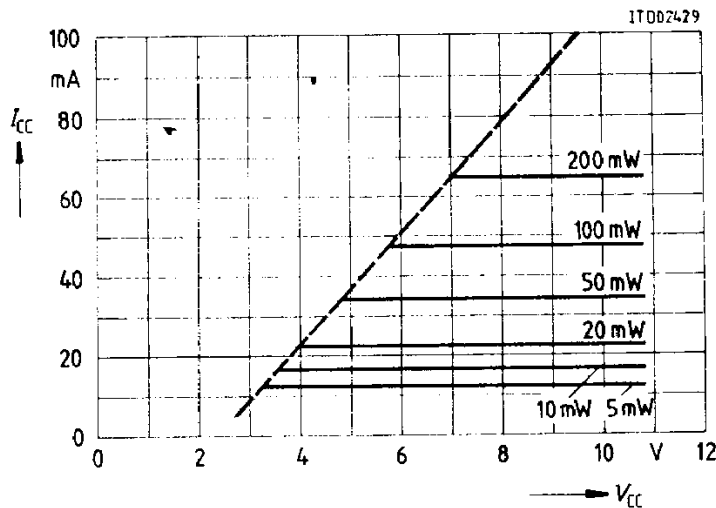
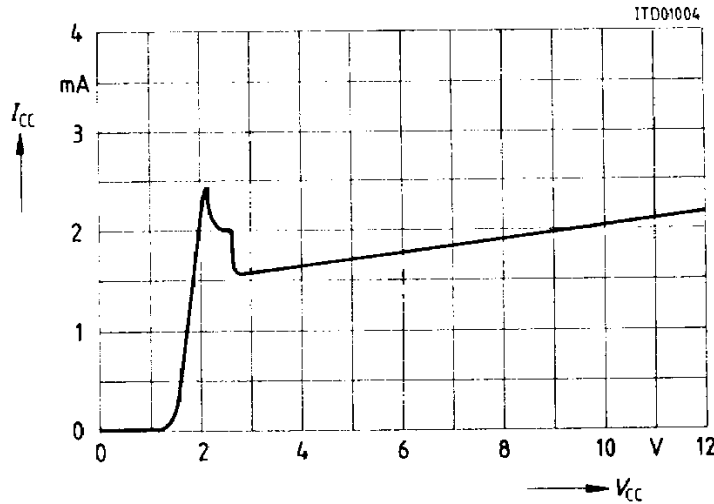

Figure 4

I_{CC} versus V_{CC} (PD Mode)



Reference Voltage V_R (4)

V_R is a buffered band gap reference at a typical value of 1.26 V with a push-pull out-put stage so it can source 0.5 mA and sink 0.2 mA at a very low output impedance of only a few ohms combined with a filter capacitor of 1 to 10 μ F to ground.

Internal Supply Voltage V_S (15)

V_S is a regulated voltage with an included short circuit protection and tracks V_R with a nominal factor 2. All internal circuitry except the speaker amplifier is sourced by this supply. An additional source current of about 1 mA for external circuitry is available. The regulation will be maintained as long as V_{CC} is typically 0.2 V higher than the regulated value of V_S . A 10 μ F capacitor to ground is required for noise suppression and stability reasons.

Microphone Amplifier; FMI (14), HMI (13), HMI2 (12), TXO (11), TO (16)

The IC is equipped with two separate microphone inputs which can be activated by the HS/HF pin. One input is for an electret microphone with a nominal input resistance of 10 k Ω and the other one is for a symmetrical piezo or dynamic microphone with a nominal input resistance of 30 k Ω for each input. Both microphone inputs are referred to V_R and each works into two preamplifiers, one controlled by the "gain control circuit" with a maximum gain (19.0 dB for handset- and 24.0 dB for hands-free operation in transmit mode) for the transmit path and one uncontrolled with a fixed gain (20.0 dB resp. 25.0 dB) for detecting the microphone signal directly. For each direction an output stage with a max. output voltage swing of 0.7 V_{PP} and an output resistance of less than 10 Ω is added. For low distortion ($\leq 3\%$) the input voltages for both microphone amplifiers should not exceed 25 mVrms. The internal input resistors of the HF-microphone amplifier are not equal

Figure 6

Volume Reduction Ratio versus $V_R - V_{VLC}$ versus V_{CC}

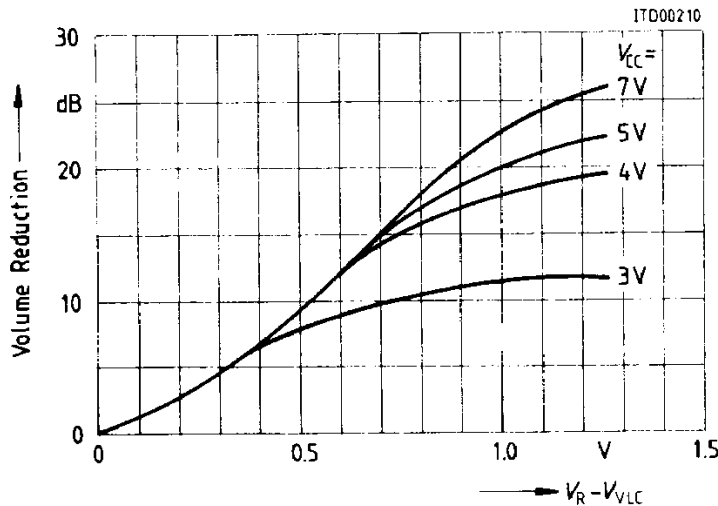
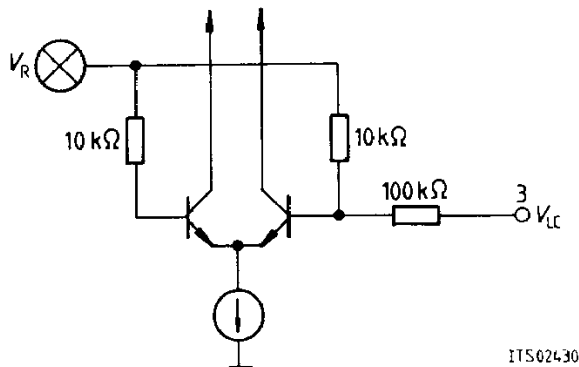

Figure 7

Volume Control Input



**Logarithmic Amplifiers; TXLI (10), TXLO (9); RXLI (7), RXLO (8)
(Transmit and Receive Level Detector)**

The log amplifiers have to MONITOR the levels of transmit and receive signals and tell the transmit-receive-comparator which mode should be in effect. The input signals are applied to the amplifiers (at TXLI and RXLI) through AC decoupling capacitors and current limiting resistors. The value of these components determine the sensitivity of the level detectors and has an effect on the switching time between transmit and receive mode. Since the input signals may vary in a wide range these amplifiers are equipped with a back-to-back diode configuration in their feedback loop providing a logarithmical gain

characteristic. The outputs of the amplifiers are rectified by a NPN transistor, allowing a short attack time and a long decay time. The attack time is determined primarily by the external capacitor (at TXLO and RXLO) and an internal $3\text{ k}\Omega$ resistor, and is in the range of milliseconds. The decay time is determined by the external resistor and capacitor, and is in the range of seconds. The switching time is not fixed, but depends on the relative values of the transmit and receive signals, as well as on the external components. The DC level at TXLI and RXLI is approximately V_R and at TXLO and RXLO about 0.6 V . The electrical schematic and the dependence of the output voltage versus input current is shown in **figure 8**.

The following trans. rec. comparator responds to the voltages at TXLO and RXLO which in turn are functions of the currents sourced out of TXLI and RXLI. Preventing noise from switching the system the comparator has a built in hysteresis that only has effect at low input signals.

If an offset at the comparator input is desired, e.g., to give preference to either the transmit or receive channel, this may be achieved by biasing the appropriate input (TXLI or RXLI). A resistor to ground will cause a DC current to flow out of that input, thus forcing the output of that amplifier to be biased slightly higher than the other. Resistor values of about $10\text{ M}\Omega$ and more are recommended for this purpose.

Figure 8

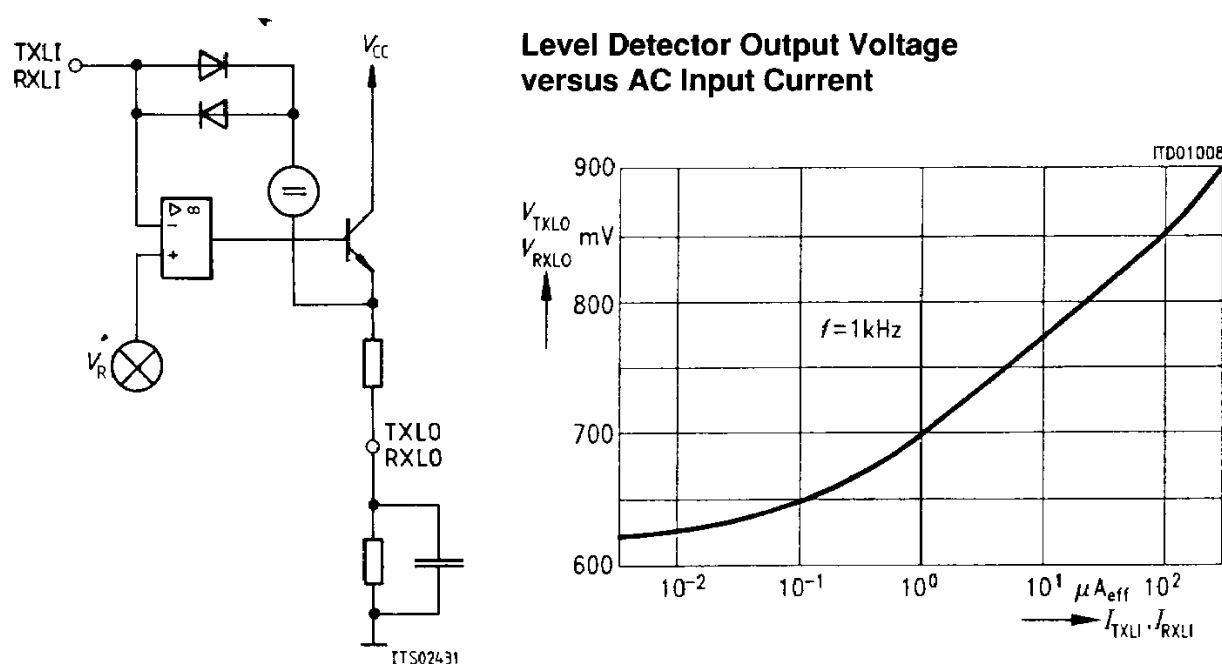

Burst Detector; TLI (17), TLO1 (18), TLO2 (19), TLO3 (20)

The burst detector has to distinguish speech from the background noise to realize an idle mode for improving sensitivity in comfortable telephone applications. This is possible because of the different characters of these two signals. Speech consists of bursts and the background noise is a relatively constant signal.

The microphone signal has to be detected in the same way as the transmit or receive level detectors do. From this output signal a voltage level which represents the average background noise will be derived and stored in the capacitor at TLO2 (pin 19). The time constant of this capacitor and additional resistor has to be in an order of several seconds. The voltage at pin 19 is applied to one input of the following transmit comparator. To the other input, which has a built in offset of 28 mV, a faster changing voltage level is applied, that is also derived from the microphone signal detector. In the absence of speech signals the same voltage will appear at both inputs and caused by the offset the output transistor of the comparator will be turned off so the voltage at TLO3 (pin 20) goes to GND. When speech is presented to the microphone and the signal burst appearing at TLI will effect a voltage change at the input of the transmit comparator that is greater than the offset voltage, the output transistor will be turned on driving the voltage at TLO3 up to approx. 1.2 V as long as the differential input voltage of the transmit comparator will approach the offset voltage. Then the output transistor will be turned off and the voltage at TLO3 goes to GND again.

Figure 9

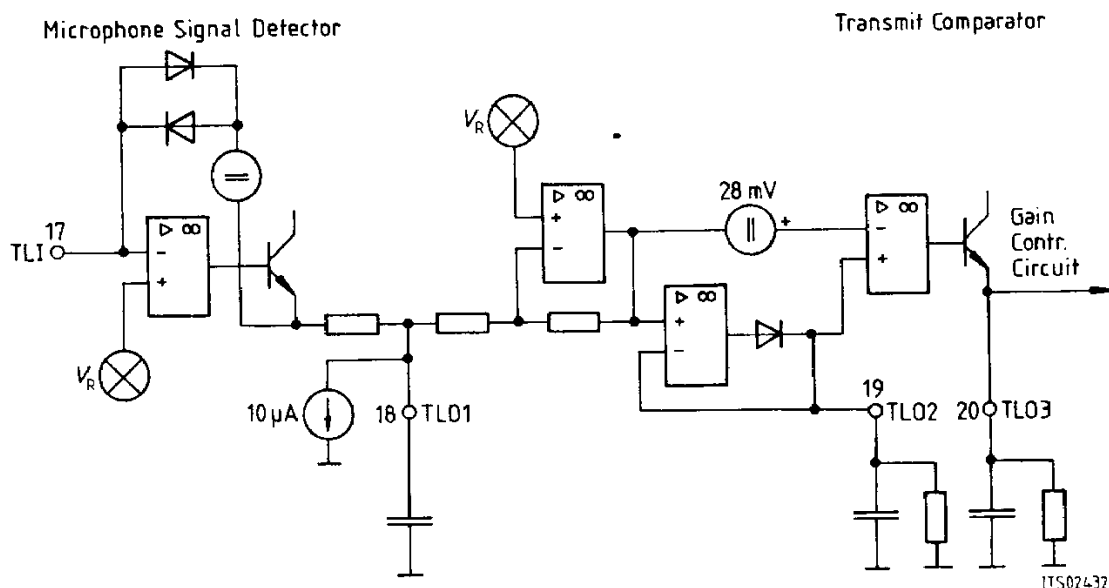
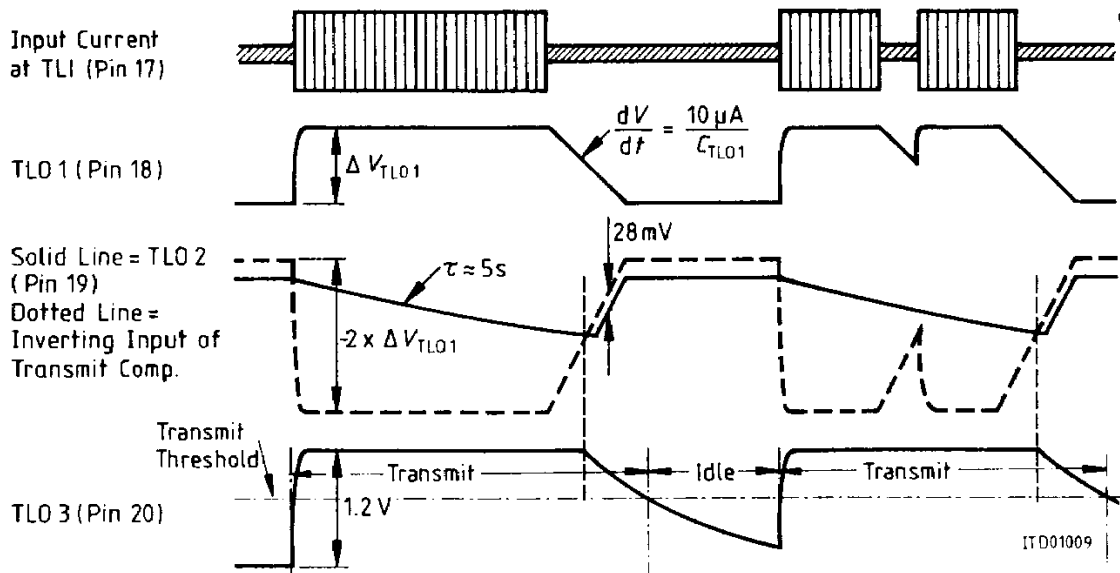

Figure 10
Burst Detector Voltages



Gain Control Circuit; HSGR (21), HFGR (22), C_T (5)

The gain control circuit has to control the gains of the transmit and receive amplifiers in all cases of operation (transmit-, idle- or receive mode) in such a way, that the product of transmit and receive gain will stay constant. That means that in the transmit mode the transmit amplifier works with its maximum gain while the receive amplifier will be attenuated by a certain adjustable factor. In the receive mode the receive amplifier works with its maximum gain (if there is no volume reduction) while the transmit amplifier will be attenuated by the same factor. In the idle mode the maximum gain of both amplifiers will be reduced by a factor which corresponds to the square root of the adjusted gain range. In the receive- and idle-mode the transmit- and receive-gain may be influenced by either the signal limiting circuit of the speaker amplifier or the volume control. Both will decrease the receive gain by a certain factor by which the transmit gain will increase (see figure 11).

The necessary gain range between transmit- and receive-mode preventing oscillation of the whole system has to be adjusted by an external resistor at the HSGR-pin (21) for loudlistening operation and at the HFGR-pin (22) for hands-free operation. The dependence of the gain range versus resistor is shown in figure 12.

The gain control circuit gets the information for switching into the right mode from the transmit-receive-comparator and from the burst detector.

A capacitor in an order of about 100 nF at the C_T pin (5) to GND suppresses transients and sets the response time of the controlled transmit and receive amplifier.

Figure 11
Principal Operation

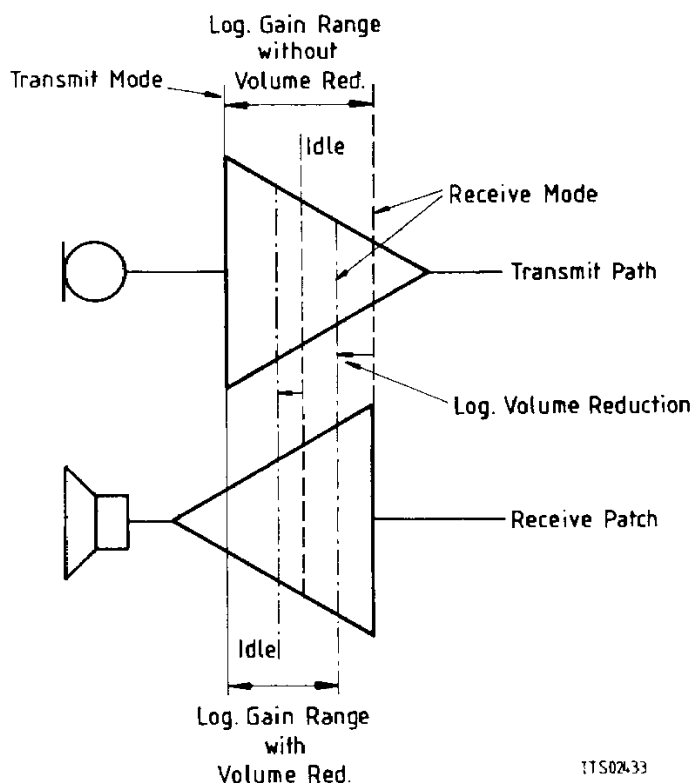

TTS02433

Figure 12

Gain Range versus R_{HFGR} and R_{HSGR}

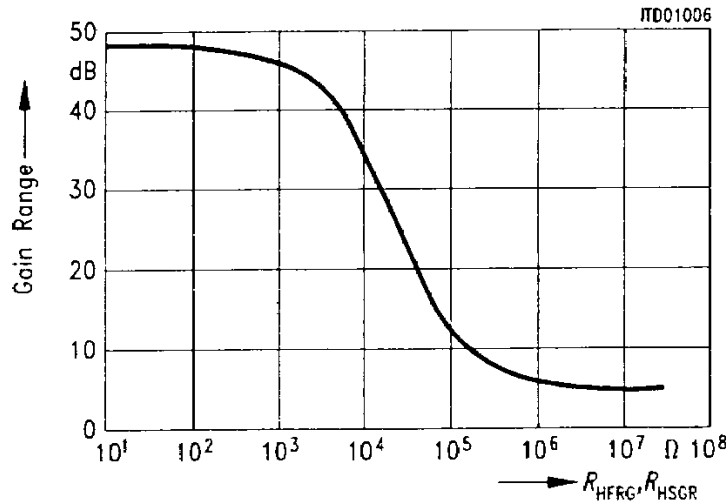

Microphone MUTE; \overline{MM} (23)

A voltage lower than 0.5 V, with a required current capability of max. 15 μ A at this pin mutes both microphone amplifiers. This pin open or a voltage higher than 1.2 V activates the microphone amplifiers.

Power Down Input; PD / \overline{SP} (24)

A voltage lower than 0.9 V, with a required current capability of max. 15 μ A at this pin activates the receiving preamplifier and the speaker output stage. This pin open or a voltage higher than 1.2 V disables the receiving preamplifier and the speaker output stage and sets the transmit path to its maximum gain.

Handset-Hands-free Switching Input; HS / \overline{HF} (25)

This pin open or a voltage higher than 1.0 V at this pin activates the handset microphone amplifier and a voltage lower than 0.5 V with a required current capability of max. 15 μ A activates the hands-free microphone amplifier.

Absolute Maximum Ratings

Voltages referred to pin 2 (GND)

Parameter	Symbol	Limit Values	Unit
Terminal voltage (pin 1)	V_{CC}	- 0.5 to 12	V
Voltage at pins without clamping diodes to V_{CC} MM (pin 23), PD/ \overline{SP} (pin 24), HS/HF (pin 25)	$V_{23, 24, 25}$	- 0.5 to 6	V
Voltage at all other pins	V	- 0.5 to $V_{CC} + 0.5$	V
Operating temperature	T_A	0 to 70	°C
System temperature	T_{Syst}	125	°C
Thermal resistance to ambient	P-DIP-28 $R_{th A}$	55	K/W
Total power dissipation	P-DIP-28 P_{tot}	850	mW
Thermal resistance to ambient	P-DSO-28 $R_{th A}$	t. b. n.	K/W
Total power dissipation	P-DSO-28 P_{tot}	t. b. n.	mW
Storage temperature	T_{stg}	- 40 to 125	°C

Recommended Operating Condition

Parameter	Symbol	Limit Values	Unit
Terminal voltage (pin 1)	V_{CC}	3 to 10	V
MM (pin 23), PD/ \overline{SP} (pin 24), HS/HF (pin 25)	$V_{23, 24, 25}$	0 to 6	V
V_{LC} (pin 3)	V_{VLC}	0 to V_R	V
Microphone signal (pin 12, pin 13)	$THD < 3\%$ $V_{12, 13}$	0 to 25	mVrms
Microphone signal (14)	$THD < 3\%$ V_{14}	0 to 25	mVrms
Receive input signal (6)	$THD < 3\%$ V_6	0 to 25	mVrms
Level detector input signal (pin 7, pin 10, pin 17)	$V_{7, 10, 17}$	0 to 400	μ App
Loudspeaker impedance	Z_L	50	Ω
Ambient temperature	T_A	0 to 70	°C

Electrical Characteristics

$T_A = 25^\circ\text{C}$; $V_{CC} = 4\text{ V}$; unless otherwise specified

Parameter	Symbol	Limit Values			Unit
		min.	typ.	max.	

Supply Voltages (see figure 14a)

V_{CC} supply current (without any load at V_R , V_S , SP1-SP2), pin 1 $V_{CC} = 4\text{ V}$, pin 24 open (PD mode) $V_{CC} = 4\text{ V}$, pin 24 shorted to GND	I_{CC}		1.7 2.2	2.05 2.75	mA mA
V_{REF} voltage ($V_{CC} = 4\text{ V}$), pin 4	V_R	1.22	1.26	1.30	V
Output current	I_R	-0.5		0.2	mA
Output resistance (1 kHz)	R_{OVR}			5	Ω
V_S voltage ($V_{CC} = 4\text{ V}$), pin 15	V_S	2.4	2.5	2.6	V
Source current	I_S	-1			mA
Supply voltage regulation $\Delta V_S/\Delta V_{CC}$ ($3\text{ V} < V_{CC} < 10\text{ V}$)	V_{SR}			5	mV/V

Microphone Amplifiers (see figure 14b)

Parameter	Symbol	Pin	Limit Values			Unit
			min.	typ.	max.	

Hands-Free Microphone (pin 25 shorted to GND)

Input resistance	R_{FMI}	14	7.5	10	12.5	k Ω
Mic amplifier gain transmit path; (transmit-mode) $V_{FMI} = 5$ mVrms	G_{FMT}	14,11	22.5	24.0	25.5	dB
Mic amplifier gain burst detector monitor path; (fixed) $V_{FMI} = 5$ mVrms	G_{FMN}	14,16	23.0	24.5	26.0	dB
Output offset voltage ($V_{TXO} - V_R$) (input open, transmit mode)	V_{OFF}	11		-20		mV

Hands-Set Microphone (pin 25 open)

Input resistance (each input)	R_{HMI}	12,13	22.5	30	37.5	k Ω
Mic amplifier gain transmit path; (transmit-mode)	G_{HMT}	12,13 11	17.8	19.3	20.8	dB
Mic amplifier gain noise monitor path; (fixed) $\Delta V_{HMI} = 5$ mVrms	G_{HMN}	12,13 16	18.5	20	21.5	dB
Output currents	I_{TXO} I_{TO}	11 16	-0.5 -0.5		1 1	mA mA
Output resistances	R_{TXO} R_{TO}	11 16			10 10	Ω Ω

Receive Amplifier (see figure 14c) ($\overline{PD/SP}$ shorted to GND; receive mode)

Input resistance	R_{RXI}	6	100			k Ω
Receiving gain; (RXI to different. output; V_{Lc} connected to V_{REF}) $V_{RXI} = 5$ mVrms	G_{REC}	6 27,28	41.5	43	44.5	dB
Output offset voltage ($V_{SP2} - V_{SP1}$)	V_{OFFS}	27,28	-60		120	mV
Output voltages ($R_L = 50 \Omega$)	V_{OH} V_{OL}	27,28		V_{CC} -1.6 1.0		V V
Output power at 50 Ω load $V_{CC} = 4$ V $V_{CC} = 5$ V	P_{OUT}	27,28 27,28	20 50			mW mW

Volume Control

Min. output voltage; ($V_{SP2} - V_{SP1}$) ($V_{VLC} = 0$ V, $V_{RXI} = 8$ mV)	V_{Omin}	27,28		100	140	mVrms
--	------------	-------	--	-----	-----	-------

Parameter	Symbol	Pin	Limit Values			Unit
			min.	typ.	max.	

Logarithmic Amplifiers
Transmit – Receive Level Detector (see figure 14d)

Diff. DC input resistance ($I_{RXLI}, I_{TXLI} \pm 100 \text{ nA}$)	R_{RXLI}	7		60		Ω
	R_{TXLI}	10				
Detector output differential voltage ($V_{RXLO} - V_{TXLO}$) ($I_{RXLI}, I_{TXLI} = 10 \mu\text{A}$)	ΔV_{RTD}	7,8	-5		5	mV
		10,9				
Detection sensitivity (output voltage change caused by an input current ratio of 2 within a current range from $-0.1 \mu\text{A}$ to $-100 \mu\text{A}$)	ΔV_{RXLO}	7,8		18		mV
	ΔV_{TXLO}	10,9				
Output resistance	R_{RXLO}	8		3		k Ω

Burst Detector (see figure 14e)

Input resistance	R_{TLI}	17		60		Ω
Detection sensitivity (output voltage change caused by a input current ratio of 2; within a current range from $-0.1 \mu\text{A}$ to $-100 \mu\text{A}$)	V_{TLO1}	17,18		18		mV
Current source	I_{TLO1}	18	7.5	10	12.5	μA
TLO3 voltage	V_{TLO3}	20		1.2	0.1	V
Burst detection sensitivity (input current ratio which is necessary to change TLO3 from low to high)	I_{RTL1}	17			1.8	

Parameter	Symbol	Pin	Limit Values			Unit
			min.	typ.	max.	

Gain Control Circuit (see figure 14b, e)

Gain range adjust HSGR, HFGR open (pin 21, 22)	GR_{min}	21,22		5.5		dB
HSGR, HFGR shorted to GND (pin 21, 22)	GR_{max}	21,22		48		dB
Gain range (10 k Ω to GND at HFGR or HSGR)	GR_{10k}	21,22	29.8	32.3	34.8	dB
Voltage C_T (depends on gain range)						
Transmit mode (pin 5) 6 dB	V_{CTTr}	5		1.63		V
Idle mode (pin 5)	V_{CTId}	5		1.51		V
Receive mode (pin 5)	V_{CTRec}	5		1.41		V
Transmit mode (pin 5) 40 dB	V_{CTTr}	5		1.63		V
Idle mode (pin 5)	V_{CTId}	5		1.15		V
Receive mode (pin 5)	V_{CTRec}	5		1.00		V

Logic Inputs

Microphone MUTE (see figure 14f)

H-input voltage	V_{MMH}	23	1.2			V
L-input voltage	V_{MML}				0.5	V
Input current (active low)	I_{MML}		-15	-10		μ A

Powerdown-Speaker Switch

H-input voltage	V_{PD}	24	1.2			V
L-input voltage	V_{SP}				0.9	V
Input current (active low)	I_{SP}		-15	-10		μ A

Handset-Hands-Free Switch

H-input voltage	V_{HS}	25	1.0			V
L-input voltage	V_{HF}				0.5	V
Input current (active low)	I_{HF}		-15	-10		μ A

Figure 13
Basic Test Circuit

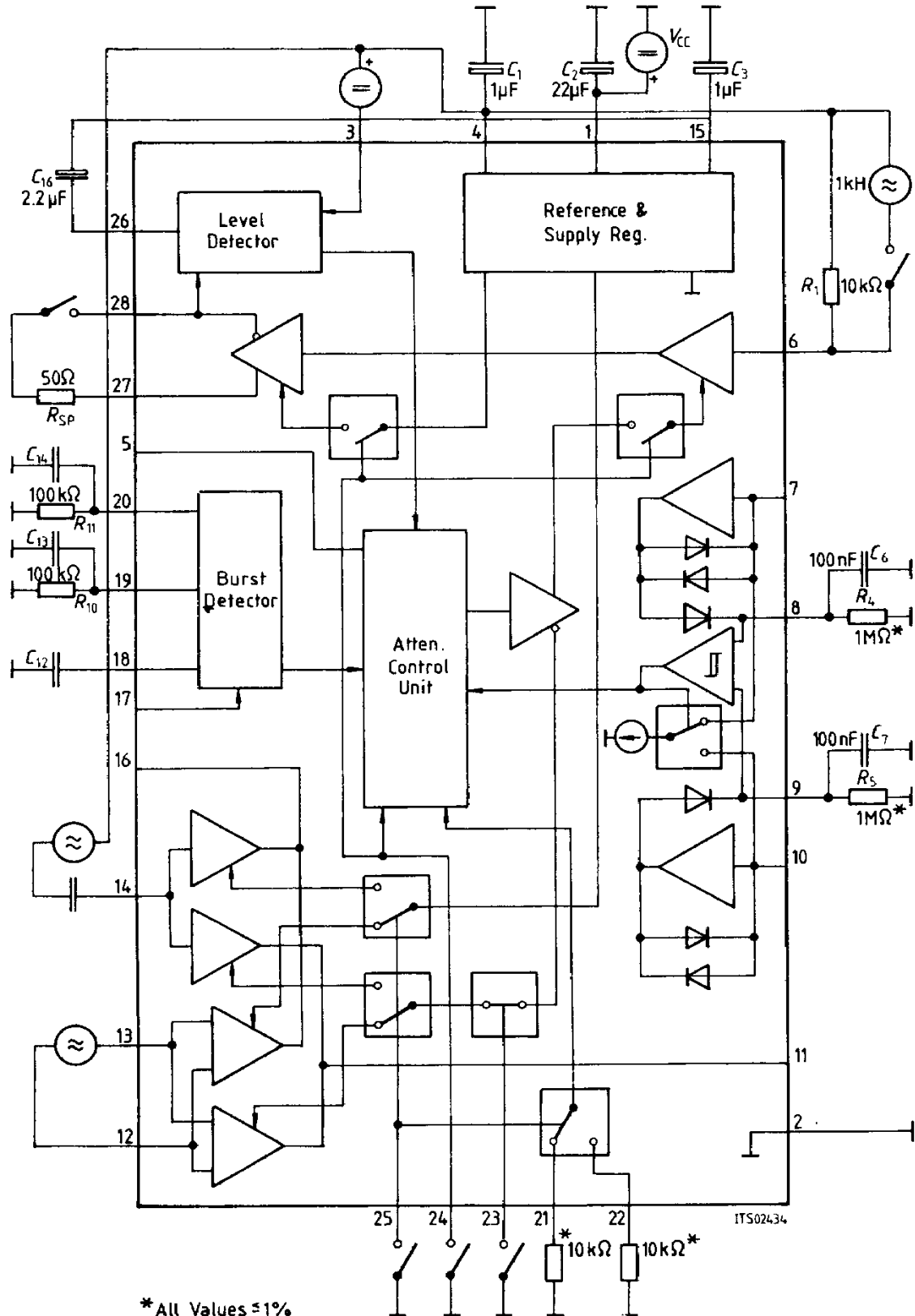

Figure 14a
Test Circuit for Supply Unit

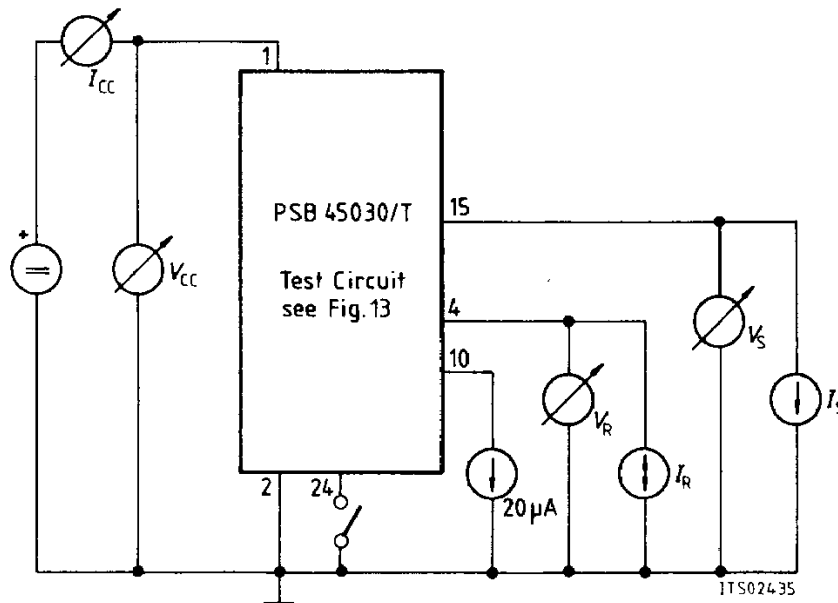

Figure 14b
Test Circuit Microphone Amplifiers

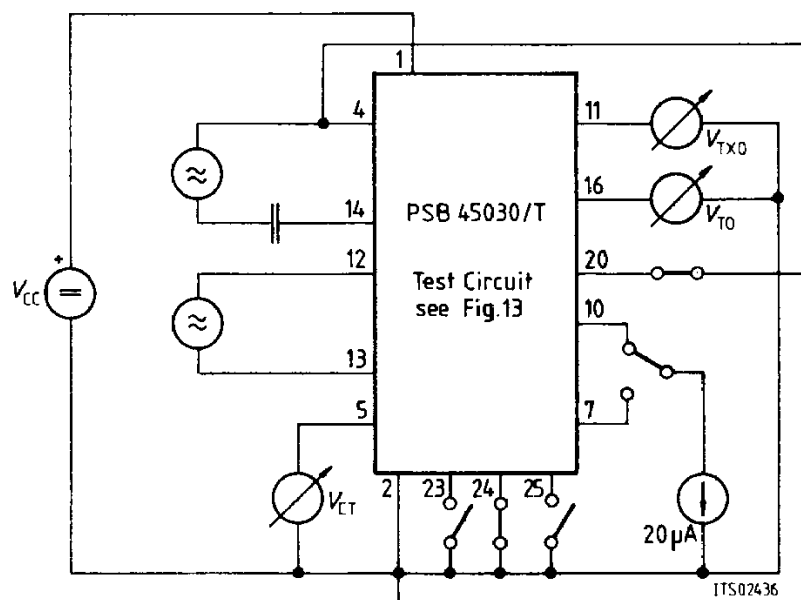

Figure 14c

Test Circuit for Receive Amplifier with Volume Control

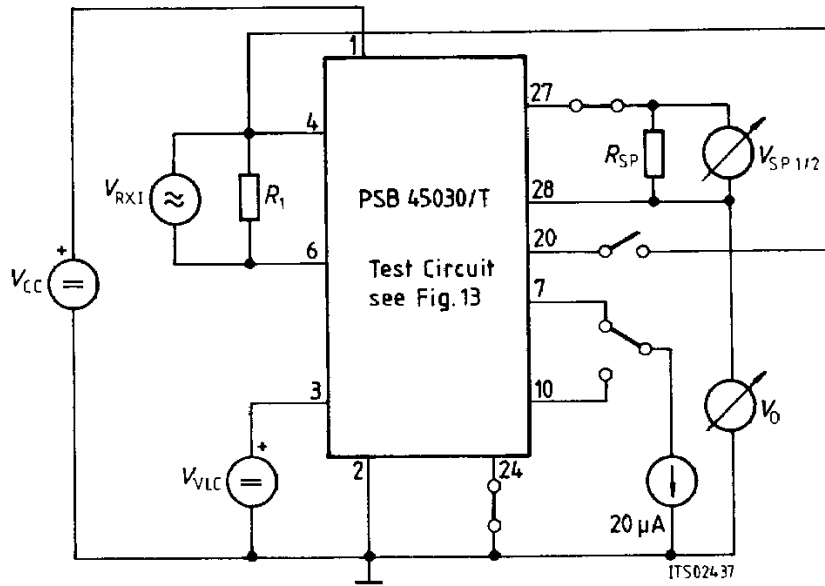

Figure 14d

Test Circuit for Level Detectors

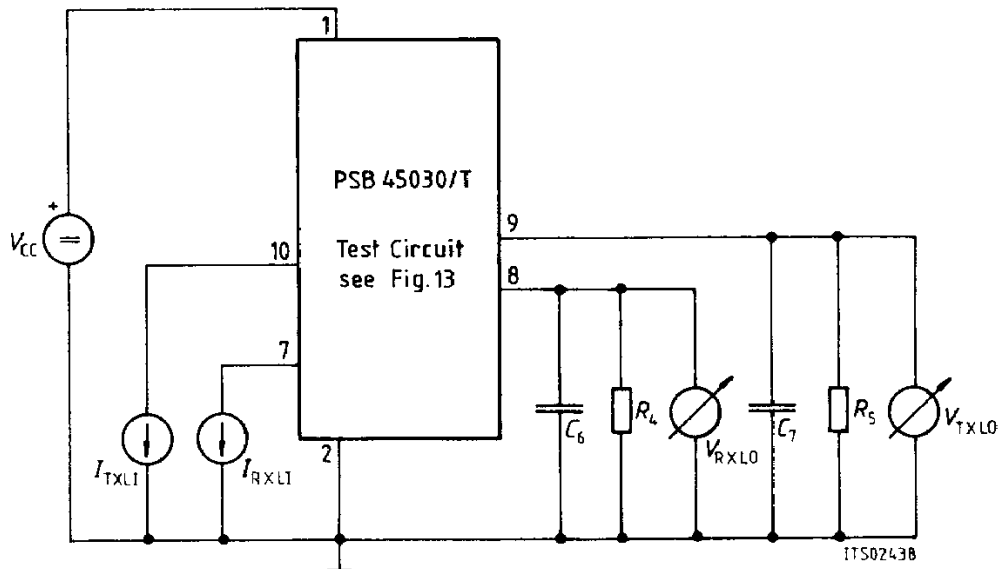

Figure 14e
Test Circuit for Burst Detector

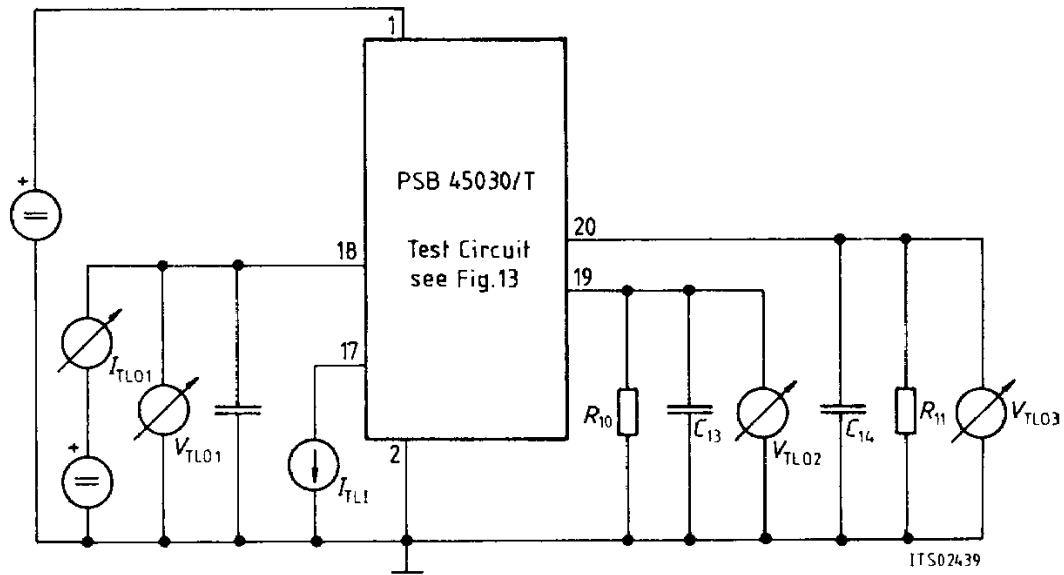
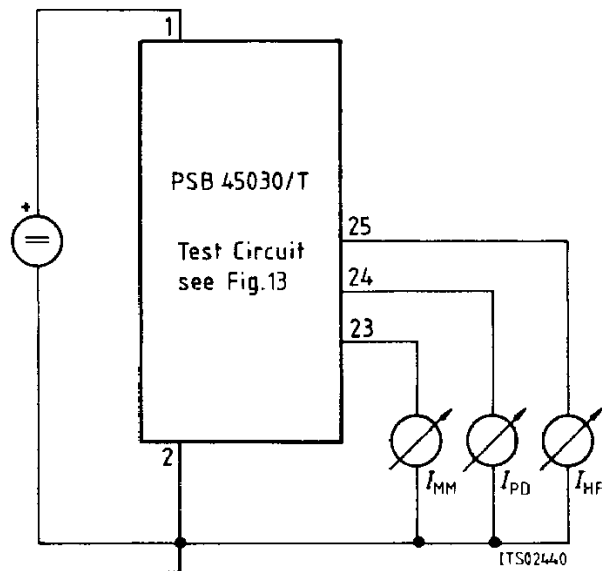

Figure 14f
Test Circuit for Digital Inputs



Application Circuit for Interconnecting PSB 2160 (ARCOFI®) and PSB 45030 (HAC) in a Digital Telephone Application

