

M56785FP

SPINDLE MOTOR DRIVER

DESCRIPTION

The M56785FP is a semiconductor integrated circuit in order to drive the spindle motor.

FEATURES

- Large power dissipation (Power Package).
- 3.3V DSP available.
- The supply voltage with wide range.
- High motor drive current.
- Low saturation voltage. (typical 1.2V at load current 500mA)
- Motor current control for both motor torque directions.
- Reverse torque mode select [SHORT BRAKING,etc].
- Sleep mode. (Zero total current)
- Hall amplifier sensitivity select.
(Minimum voltage : 35mVp-p or 50mVp-p)
- FG signal output terminal.
- Automatic stop select. (Removable function)
- Reverse detected signal pin.

APPLICATION

CD-ROM,DVD,DVD-ROM,DVD-RAM etc.

PIN CONFIGURATION (TOP VIEW)

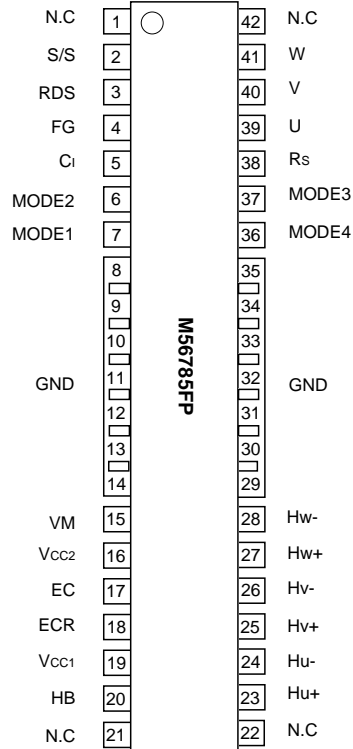

Outline 42P9R-A

N.C: no connection

BLOCK DIAGRAM

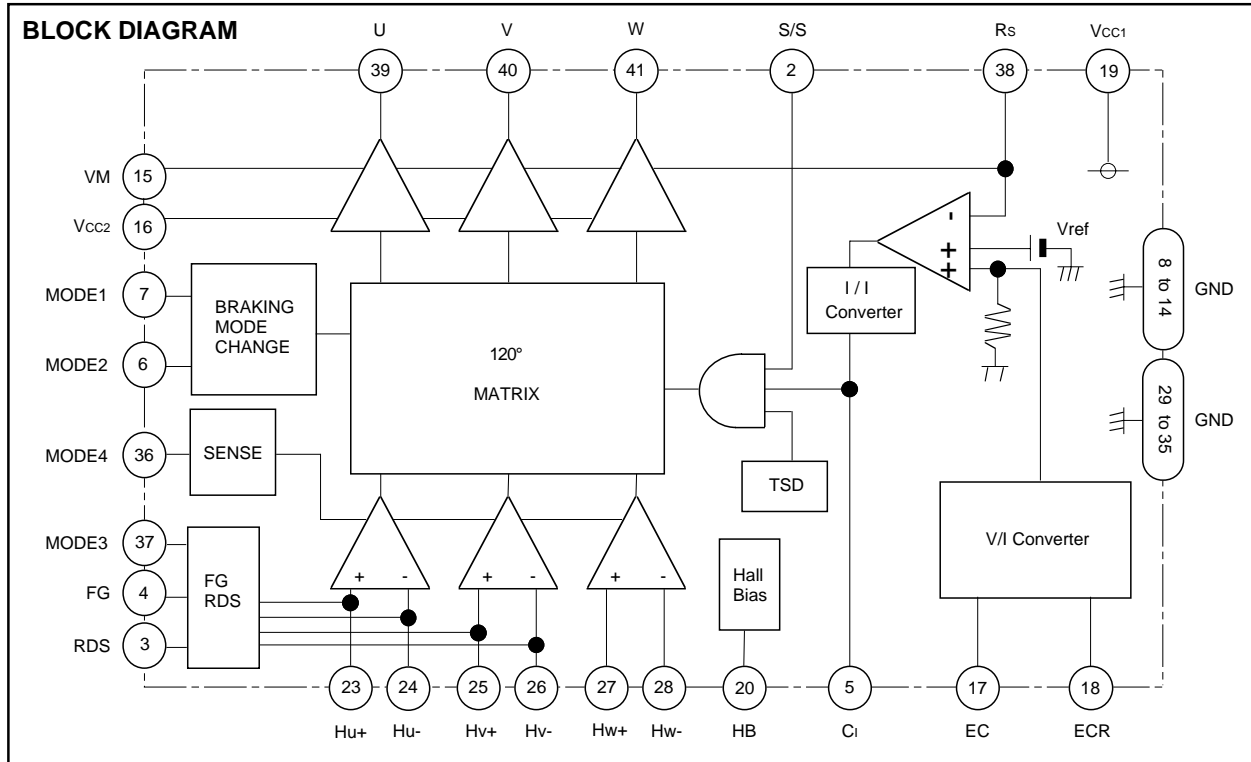

M56785FP

SPINDLE MOTOR DRIVER

PIN DESCRIPTION

Pin No.	Symbol	Function	Pin No.	Symbol	Function
①	N.C	—————	②②	N.C	—————
②	S/S	Start / Stop	②③	Hu+	Hu+ Sensor amp. input
③	RDS	Reverse detected signal	②④	Hu-	Hu- Sensor amp. input
④	FG	Frequency generator output	②⑤	Hv+	Hv+ Sensor amp. input
⑤	C _I	Phase Compensation	②⑥	Hv-	Hv- Sensor amp. input
⑥	MODE2	Reverse torque mode select 2	②⑦	Hw+	Hw+ Sensor amp. input
⑦	MODE1	Reverse torque mode select 1	②⑧	Hw-	Hw- Sensor amp. input
⑧—⑭	GND	GND	②⑨—③⑤	GND	GND
⑮	VM	Motor supply voltage	③⑥	MODE4	Hall amplifier sensitivity select
⑯	Vcc2	12V supply voltage	③⑦	MODE3	Automatic stop select
⑰	EC	Motor speed control	③⑧	Rs	Motor current sense
⑱	ECR	The reference voltage for EC	③⑨	U	Motor drive output U
⑲	Vcc1	5V supply voltage	④①	V	Motor drive output V
⑳	HB	Bias for Hall Sensor	④②	W	Motor drive output W
㉑	N.C	—————	④③	N.C	—————

* Pull-up resistors (10kohm) are included in the circuits connected to ③ pin [RDS] and ④ pin[FG].

ABSOLUTE MAXIMUM RATING (Ta=25°C)

Symbol	Parameter	Conditions	Rating	Unit
VM	Motor supply voltage	⑮ pin	16	V
Vcc2	12V supply voltage	⑯ pin	16	V
Vcc1	5V supply voltage	⑲ pin	7.0	V
Io	Output current	Note 1	1.5	A
VH(c)	Sensor amp. Differential input range	②③—②⑧ pins	4.5	V
Pt	Power dissipation	Free Air	1.2	W
Kθ	Thermal derating	Free Air	9.6	mW/°C
Tj	Junction temperature		150	°C
Topr	Operating temperature		-20 – +75	°C
Tstg	Storage temperature		-40 – +125	°C

*Note1 ; The ICs must be operated within the Pt (power dissipation) or the area of safety operation

M56785FP

SPINDLE MOTOR DRIVER

RECOMMENDED OPERATING CONDITIONS

Symbol	Parameter	Limits			Unit
		Min.	Typ.	Max.	
Vcc1	5V Power supply	4.5	5.0	5.5	V
Vcc2	12V Power supply	4.5	12.0	13.2	V
VM	Motor Power supply	4.5	12.0	13.2	V
Io	Output drive current	—	—	700	mA

ELECTRICAL CHARACTERISTICS (Vcc=5V, Vcc2=12V, VM=12V, Ta=25°C unless otherwise noted.)

Symbol	Parameter	Conditions	Limits			Unit
			Min.	Typ.	Max.	
Icc1	Sleep Mode Supply current- 1	⑮and⑯pin total Input Current (② pin low or open)	—	0	100	μA
Icc2	Sleep Mode Supply current- 2	⑰pin Input Current (② pin low or open)	—	—	500	μA
Icc3	Supply current- 3	⑰pin Input Current (EC=ECR=2.5V) [②pin High]	—	—	6.0	mA
Vsat	Saturation voltage	Top and Bottom saturation voltage. (Load current :500mA)	—	1.2	1.9	V
ECdead-	Dead Zone Control voltage dead zone	EC < ECR	-40	-21	0	mV
ECdead+		EC > ECR	0	+21	+40	
ECR	Reference voltage Input range	⑰pin [3.3v DSP available]	0.5	1.65	4.0	V
EC	Control voltage Input range	⑰pin [3.3v DSP available]	0.5	1.65	4.0	V
Gio	Control gain	Io = Gio / Rsense [A/V]	0.25	0.3	0.35	V/V
Vlim	Control limit	Ilim = Vlim / Rsense [A]	0.27	0.3	0.33	V
VH com	Hall sensor amp common mode input range	⑳-㉑pins	1.2	—	4.5	V
VHmin1	Hall sensor amp. input signal revel	⑳-㉑pins	MODE4=OPEN or HIGH	50	—	mV
VHmin2			MODE4=GND	35	—	
VHb	Hall bias terminal output voltage	Load current (IHb) =10 mA.	0.6	0.85	1.2	V
IHb	Hall bias terminal sink current		—	—	30	mA
Von	Motor start voltage	②pin input voltage when it starts up the motor. *The IC is in the active condition. *The hall bias is available.	2.0	—	—	V
Voff	Motor stop voltage	②pin input voltage when it stops the motor. *The IC is in the sleep condition. *The hall bias is off.	—	—	0.8	V
Vih	mode pin input high voltage	⑦pin[MODE1],⑥pin[MODE2],⑰pin[MODE3] and⑳pin[MODE4] input voltage when they are HIGH.	2.0	—	—	V
Vil	mode pin input low voltage	⑦pin[MODE1],⑥pin[MODE2],⑰pin[MODE3] and⑳pin[MODE4] input voltage when they are LOW.	—	—	0.8	V
VOL	3pin[RDS],4pin[FG] output low voltage	Io current = 1mA	—	—	0.5	V

M56785FP

SPINDLE MOTOR DRIVER

ELECTRICAL CHARACTERISTICS (V_{CC1}=5V, V_{CC2}=12V, V_M=12V, T_a=25°C Unless otherwise noted.)

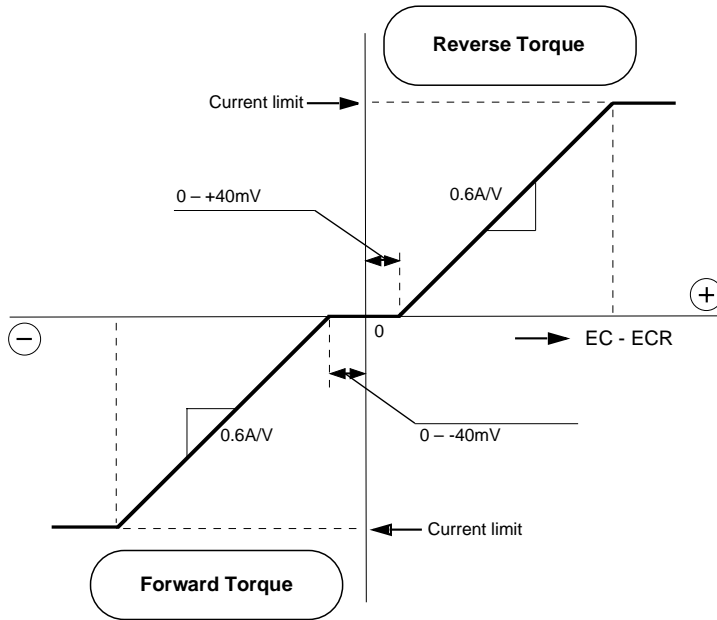

The relationship between the EC-ECR (the difference between EC<control voltage> and ECR <reference voltage>) and the torque is shown in Figure 1. The current gain is 0.6A/V (at sensing resistor :0.5ohm) in both torque directions, and the dead zone is from ±0mV to ±40mV. When the all short brake mode is selected, the coil current under the reverse torque control depends on the back emf. and the coil resistance.

Figure 1. The characteristics of the control voltage and motor current (Torque).

THERMAL DERATING

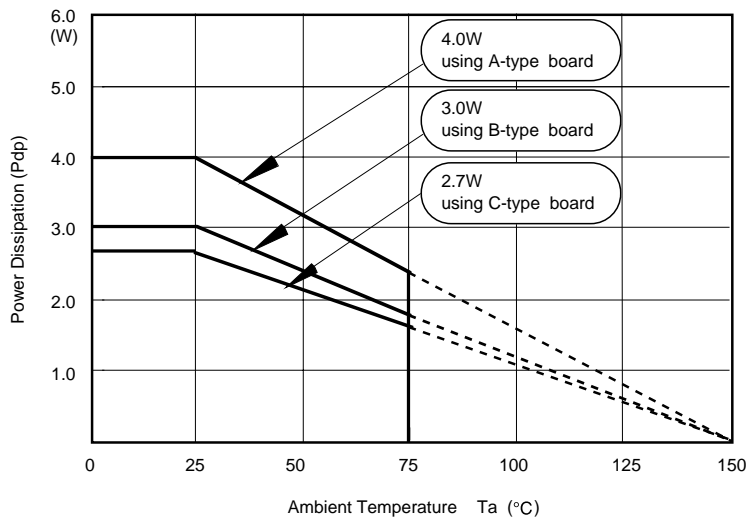

This IC's package is POWER-SSOP, so improving the board on which the IC is mounted enables a large power dissipation without a heat sink. For example, using an 1 layer glass epoxy resin board, the IC's power dissipation is 2.7W at least. And it comes to 4.0W by using an improved 2 layer board. The information of the H, I, J type board is shown in the board information.

HALL AMPLIFIER INPUT AND COMMUTATION

The relationship between the hall amplifier inputs voltage and the motor current outputs is shown in Figure 2.

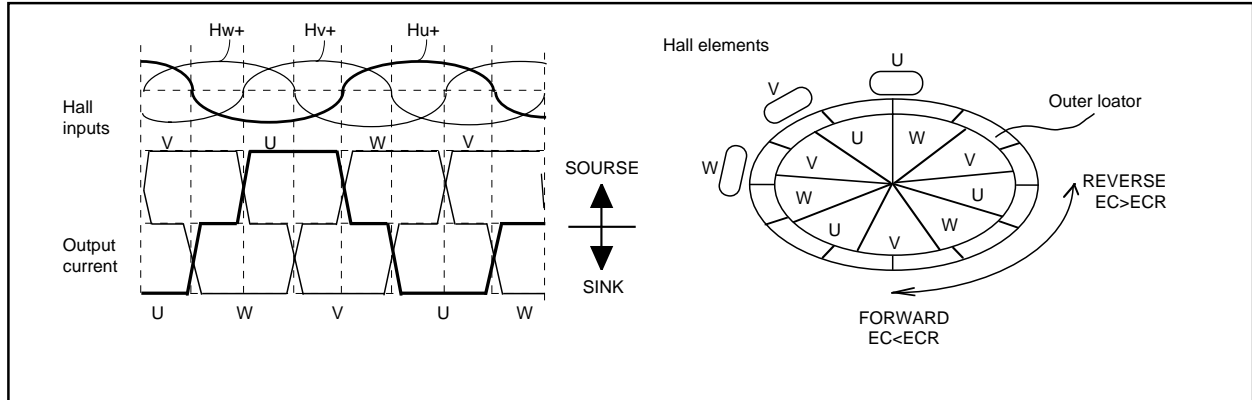

Figure 2.

HALL AMPLIFIER INPUT SENSITIVITY SELECT

MODE4	
OPEN or HIGH	GND
120 degree soft switching	120 degree switching ** I _o current changes sharply.
The hallamp minimum input voltage is 50 mVp-p.	The hallamp minimum input voltage is 35 mVp-p.

Figure 3.

Figure 3 shows the hall amplifier input sensitivity select function. You are able to select a sensitivity of a hall amplifier out of two levels which is suitable for the hall elements type. If the output minimum level of the hall elements is lower than 50mVp-p, please connect the MODE4 pin to external GND. In this case, the output current changes shaply. If the output minimum level of the hall elements is higher than 50mVp-p, please make the MODE4 pin open, then the output current is commutated softly. We recommend that the output level of the hall elements be set between 80mVp-p and 120mVp-p, and the MODE4 pin is an open.

SLEEP MODE FUNCTION

START / STOP (Ⓜ pin)	
LOW or OPEN	HIGH
Motor Stop	Motor on
Bias off	Bias on
Hall-Bias of	Hall-Bias on

Figure 4.

Figure 4 shows the sleep mode function. If the Ⓜ pin [S/S] is set to be open or low, the motor drive outputs have high impedance and the motor stops. Then, the IC bias current wil be a slight current (please refer to the electrical characteristics), and the hall bias output will be cut off. When the Ⓜ pin input is high, all the circuits will work.

FORWARD AND REVERSE ROTATION DETECT FUNCTION

Figure 5 shows the circuits and the functions of the forward and reverse rotation detect .

The output of the RDS pin is determined by the signals of hall inputs (Hu+, Hu-, Hv+ and Hv-) which indicate the direction of rotation. When the motor is spinning forward, the RDS pin output will be low. When the motor rotates reversely in stop mode, it will be high.

The RDS pin is pulled-up to Vcc1 by internal resistor (typ.10kohm).

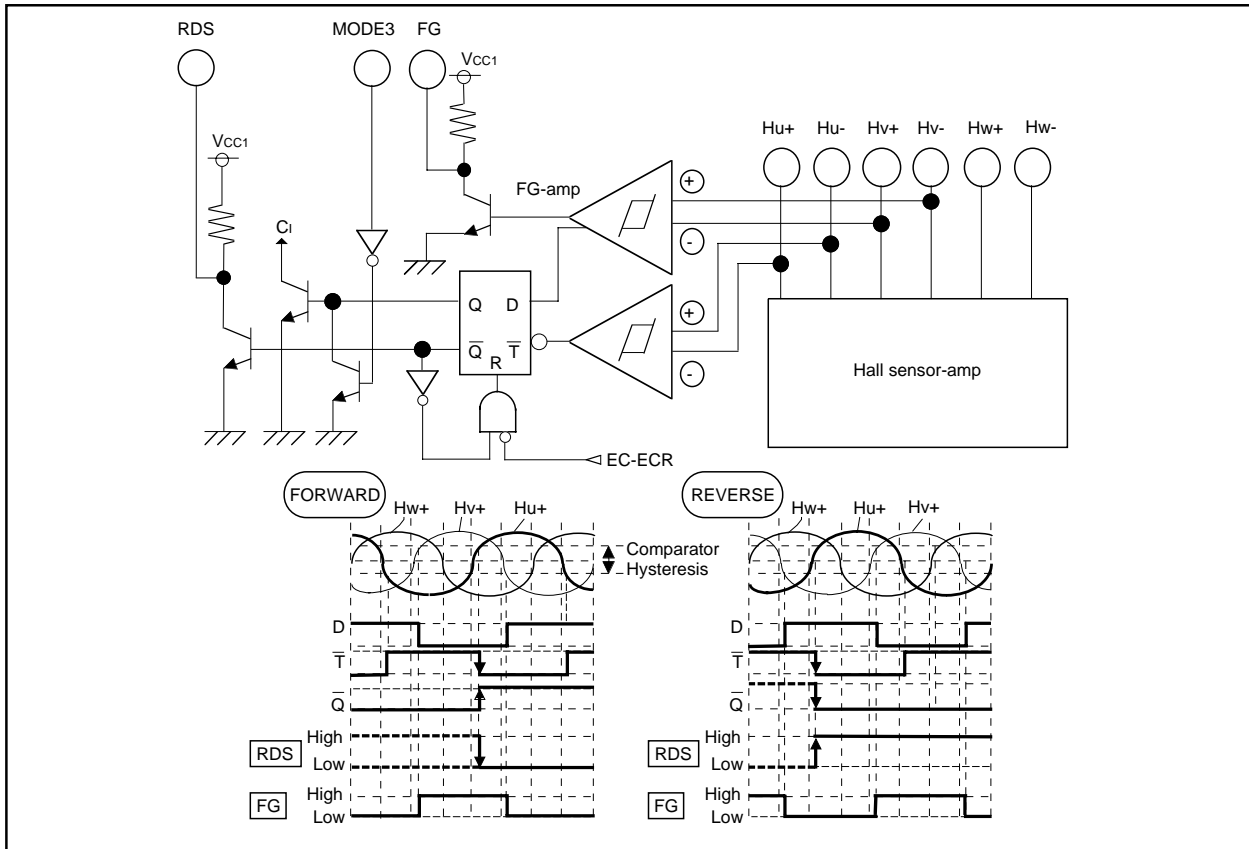

Figure 5.

M56785FP

SPINDLE MOTOR DRIVER

AUTOMATICALLY STOP AFTER REVERSE BRAKING FUNCTION

Figure 5 also shows the automatically stop (after the reverse braking) circuit. Figure 6 is its function table which shows whether the automatically stop function is on or off, and its state is determined by MODE3 input.

When the MODE3 is open or high, the motor will stop rotating automatically after the reverse braking.

When the MODE3 is low or connected to GND, the motor will continue the reverse rotation. This function is useful for the case that the system doesn't require the automatically stop function, and in the system a motor receives a stop command from the outside of this IC. For example, a μ com can detect the reverse rotation from the RDS pin output, and can control all the torque of a motor. So it can stop the motor outside this IC.

FG FUNCTION

Figure 5 also shows the circuits and the functions of the frequency generator. The FG pin outputs the square pulse signal synchronizing with the hall inputs [Hv+ and Hv-] timing.

The FG pin is pulled-up to V_{CC1} by an internal resistor [typ. 10Kohm].

MODE3	
OPEN or HIGH	GND
AUTOMATIC STOP	UN-AUTOMATIC (NON-STOP)

Figure 6.

REVERSE TORQUE MODE SELECT FUNCTION

In the 4 times speed and the 6 times speed CDROM drive system, the reverse braking style has been used for a deceleration of the rotation speed. However, in the CDROM drive system above an 8 times speed, the motor current above 0.5A is needed, because a high speed access time are required for motor driver ICs. If the reverse braking is used at 0.5A, the IC junction temperature will be too much high, and the heat loss of the IC will be large.

Therefore, this motor driver has the braking mode select function (REVERSE BRAKING MODE and SHORT BRAKING MODE). The braking mode can be determined by the external logic signals synchronizing with servo timing, and it can make a heat loss of the IC smaller by adjusting the junction temperature.

Figure 7 shows the reverse torque mode select function table. If you want the former braking style (the reverse braking), please select only the REVERSE BRAKING mode [MODE1=LOW or OPEN and MODE2=HIGH]. But the heat loss will be larger, and sometimes external heat sink would be necessary.

If it is possible to get ports more than two from μ com, you can flexibly control the four kinds of BRAKING MODE. So the heat loss can be half as usual. For example, the REVERSE BRAKING MODE is on under the CLV control, and the ALL SHORT BRAKING MODE is for seeking. When the motor should be stopped, the ALL SHORT BRAKING MODE or the REVERSE BRAKING MODE is available.

If you can only get one port, you can control only the MODE2. At this time, you can control the two kinds of BRAKING MODE [commutated short or reverse] on condition that the MODE1 is set to be LOW or OPEN.

BRAKING MODE (ECR < EC) SELECT FUNCTION TABLE			
		MODE1	
		LOW or OPEN	HIGH
MODE2	LOW or OPEN	COMMUTATED SHORT BRAKING	ALL SHORT BRAKING
	HIGH	REVERSE BRAKING	OUTPUT OPEN [only inertia]

Figure 7.

REVERSE TORQUE MODE SELECT FUNCTION

Figure 8 shows an example for the reverse torque mode select. The CASE1 is an example for controlled REVERSE and COMMUTATED SHORT BRAKING. The CASE2 is an example for controlled REVERSE and ALL SHORT BRAKING.

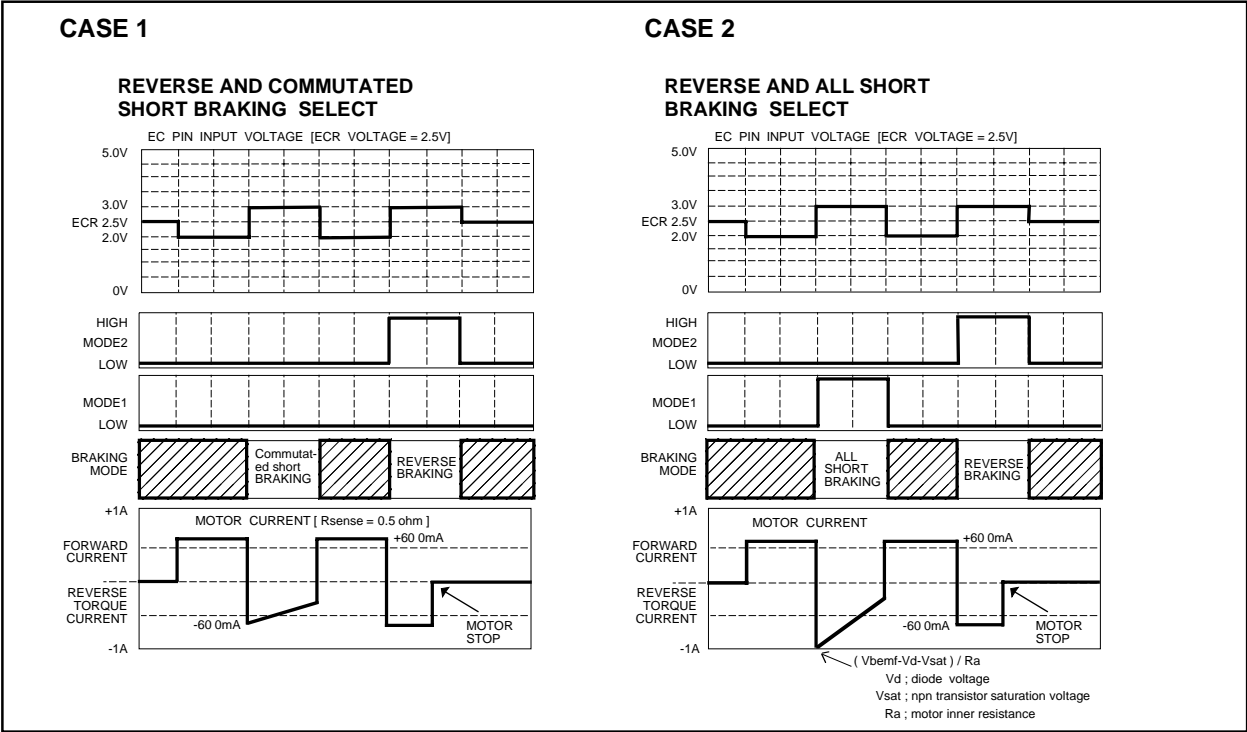
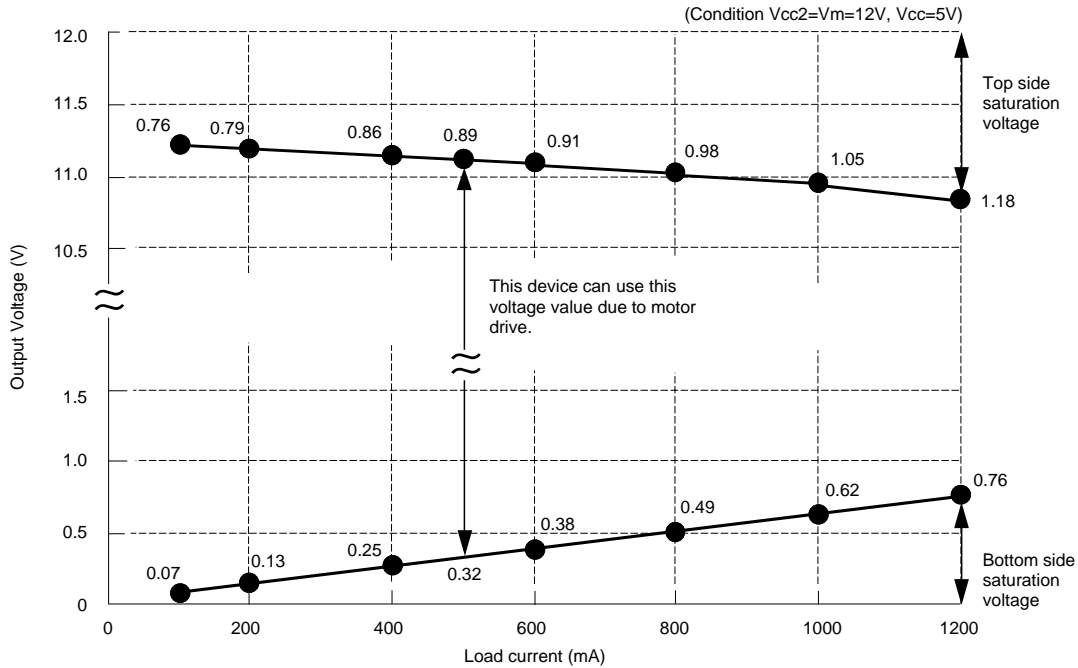

Figure 8.

BASICALLY CHARACTERISTICS

This data is an example for typical sample.

Output saturation voltage and Load current Characteristics.



Output saturation voltage and Load current Characteristics. (At bootstrap)

By taking advantage of bootstrap function, the output saturation voltage can be lower.

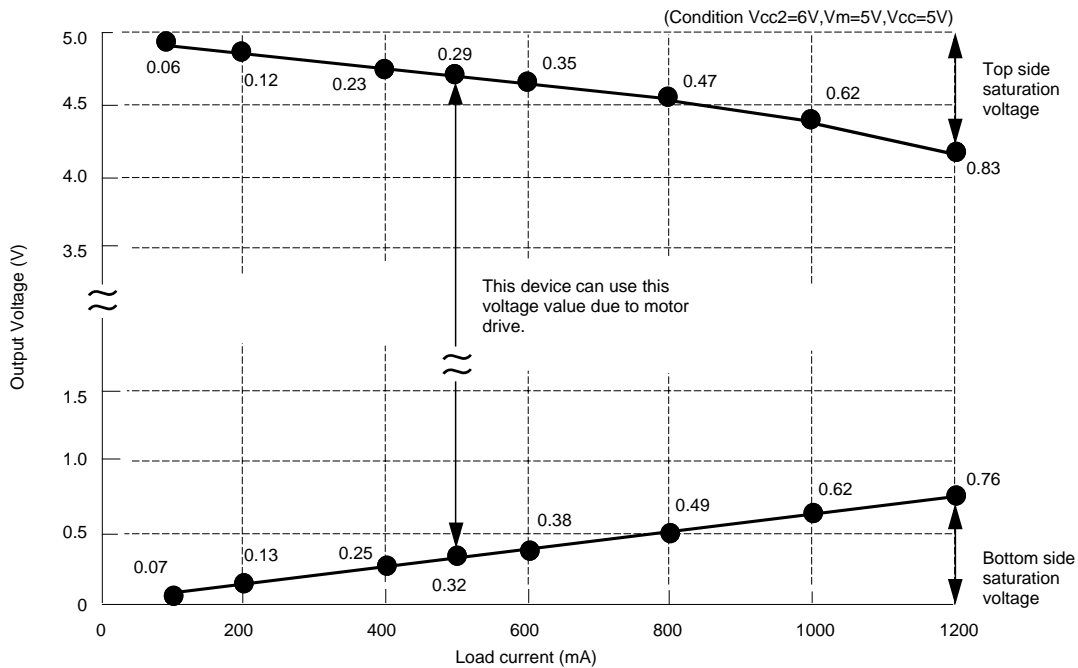

HB terminal voltage and Hall current characteristics.

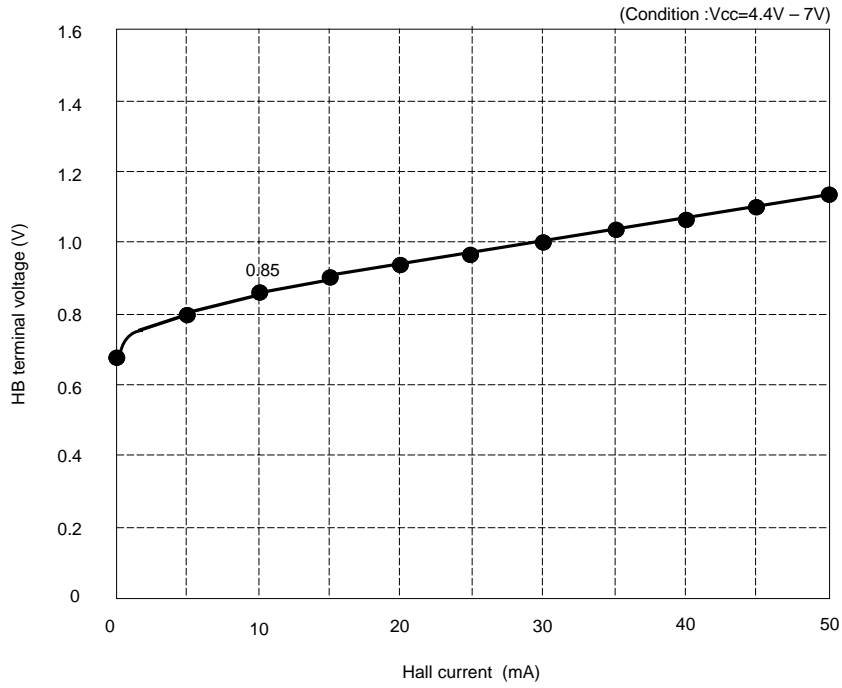

APPLICATION CIRCUIT

