



SANYO Semiconductors

DATA SHEET

LA4810M — Monolithic Linear IC Stereo/Monaural BTL Power Amplifier

Overview

The LA4810M stereo/monaural BTL power amplifier is an IC that has been developed for portable radios and compact radio cassette players/recorders containing a preamplifier, a power amplifier, and an electronic volume control

Applications

- Audio equipment such as portable radios and compact radio cassette players/recorders

Functions & Features

- 2-channel stereo power amplifier
- Stereo/monaural BTL selector
- Electronic volume control
- Incorporates two channels of low-voltage ($V_{CC}=1.8V$ or higher) drive power amplifiers
 - EIAJ output power 1=125mW typical ($V_{CC}=3V$, $R_L=8\Omega$)
 - EIAJ output power 2=280mW typical ($V_{CC}=4.5V$, $R_L=8\Omega$)
- Configurable as a monaural BTL power amplifier (selected at pin 2)
 - EIAJ output power 3=350mW typical ($V_{CC}=3V$, $R_L=8\Omega$)
 - EIAJ output power 4=600mW typical ($V_{CC}=4.5V$, $R_L=16\Omega$)
- Onchip electronic volume
- Onchip ripple filter

Specifications

Maximum Ratings at $T_a=25^\circ C$

Parameter	Symbol	Conditions	Ratings	Unit
Maximum supply voltage	V_{CC} max		8	V
Allowable Power Dissipation	P_d max1	$T_a \leq 60^\circ C$, when mounted on a PCB*	700	mW
Operating Temperature	T_{opr}		-10 to +60	$^\circ C$
Storage Temperature	T_{stg}		-40 to +150	$^\circ C$

* Specified board: 114.3mm×76.1mm×1.6mm Board material: glass epoxy

- Any and all SANYO Semiconductor products described or contained herein do not have specifications that can handle applications that require extremely high levels of reliability, such as life-support systems, aircraft's control systems, or other applications whose failure can be reasonably expected to result in serious physical and/or material damage. Consult with your SANYO Semiconductor representative nearest you before using any SANYO Semiconductor products described or contained herein in such applications.
- SANYO Semiconductor assumes no responsibility for equipment failures that result from using products at values that exceed, even momentarily, rated values (such as maximum ratings, operating condition ranges, or other parameters) listed in products specifications of any and all SANYO Semiconductor products described or contained herein.

SANYO Semiconductor Co., Ltd.

TOKYO OFFICE Tokyo Bldg., 1-10, 1 Chome, Ueno, Taito-ku, TOKYO, 110-8534 JAPAN

92706 / 61305 KK JK No.8213-1/12

LA4810M

Operating Conditions at $T_a = 25^\circ\text{C}$

Parameter	Symbol	Conditions	Ratings	Unit
Recommended supply voltage	V_{CC}		3.0	V
Allowable operating supply voltage range 1	V_{CCOP1}	$R_L=8\Omega$	1.8 to 4.5	V
Allowable operating supply voltage range 2	V_{CCOP2}	$R_L=16\Omega$	3.0 to 6.0	V

* Adequate consideration must be given to the allowable power dissipation when determining the supply voltage to be used.

Electrical Characteristics at $T_a = 25^\circ\text{C}$, $V_{CC}=3\text{V}$, $f_{in}=1\text{kHz}$, $R_L=8\Omega$

Parameter	Symbol	Test Conditions	min	typ	max	Unit
Quiescent current	I_{CCOP}	No signal is present.		5.5	11	mA
Voltage gain	GS	$V_{IN}=-40\text{dBm}$	31.3	34.3	37.3	dB
BTL voltage gain	GB	$V_{IN}=-40\text{dBm}$, BTL mode	36.3	40.3	44.3	dB
Channel balance	BCH		-3	0	3	dB
Output DC offset voltage difference	DCOS	BTL mode	-80	0	80	mV
Maximum output power1	POMX1	THD=10%	90	125		mW
Maximum output power2	POMX2	THD=10%, $V_{CC}=4.5\text{V}$	180	280		mW
Maximum output power3	POMX3	THD=10%, BTL mode	220	350		mW
Maximum output power4	POMX4	THD=10%, BTL mode, $V_{CC}=4.5\text{V}$, $R_L=16\Omega$	400	600		mW
Total harmonic distortion	THDS	At $V_{IN}=-20\text{dBm}$, $P_O=50\text{mW}$		0.4	2.5	%
BTL total harmonic distortion	THDB	At $V_{IN}=-20\text{dBm}$, $P_O=50\text{mW}$, BTL mode		0.5	2.5	%
Output noise voltage	VNS	$R_g=0\Omega$, $f=20$ to 20kHz		0.45	0.9	mVrms
BTL output noise voltage	VNB	$R_g=0\Omega$, $f=20$ to 20kHz , BTL mode		0.6	1.2	mVrms
Channel separation	SCH	$V_{IN}=-40\text{dBm}$, 1kHz-BPF		-68	-58	dBm
Volume attenuation	V_{OL}	Attenuation at $V_{IN}=-40\text{dBm}$, V_{OL} at center position	3	7.5	14	dB

$0\text{dBm}=1\text{mW}$ ($R=600\Omega$) $\approx 774.6\text{mVrms}$

LA4810M

Pin Description

Pin No.	Pin Symbol	Equivalent Circuit Diagram	Pin Voltage		Description
			V _{CC} =3V	V _{CC} =4.5V	
1 16	IN2 IN1		0	0	Input pins
2	SW		1.23	1.23	MONO/BTL Selector pin
3	NC				
4 13	NF2 NF1		1.45	2.2	Power amplifier NF pins (Connect a NF capacitor across these pins.)
5 12	GND2 GND1		0	0	Preamplifier GND pins
6 11	PGND2 PGND1		0	0	Power amplifier GND pins
7 10	OUT2 OUT1		1.45	2.2	Power amplifier output pins

Continued on next page.

LA4810M

Continued from preceding page.

Pin No.	Pin Symbol	Equivalent Circuit Diagram	Pin Voltage		Description
			V _{CC} =3V	V _{CC} =4.5V	
8	RIPPLE	<p style="text-align: right;">ILA07040</p>	2.71	4.07	Ripple filter pin (Connect a filter capacitor.)
9	V _{CC}		3	4.5	Power pin
14	V _{OL}	<p style="text-align: right;">ILA07041</p>	0 to 1.23 (Apply)	0 to 1.23 (Apply)	Volume control pin
15	REG	<p style="text-align: right;">ILA07042</p>	1.23	1.23	Internal regulator pin (Connect a stabilization capacitor.)

LA4810M

Block Diagram

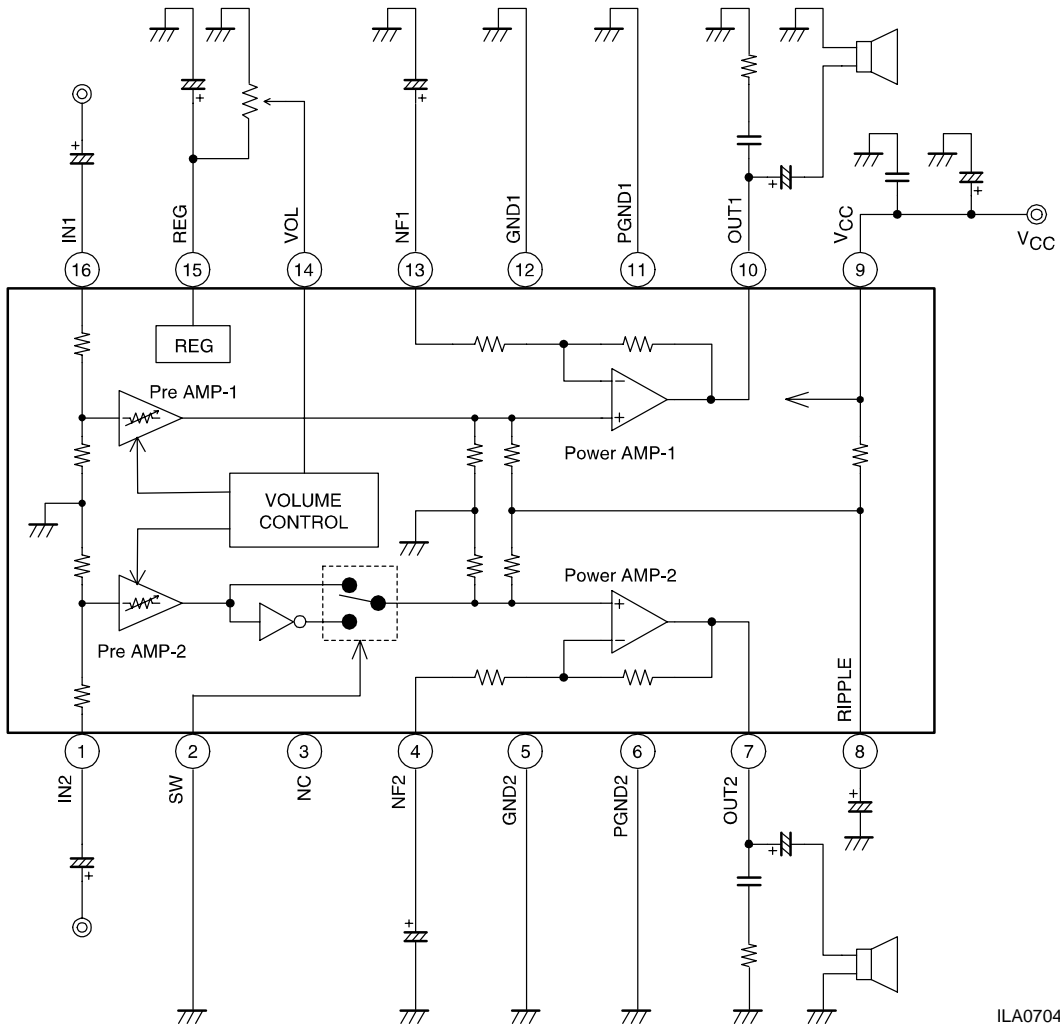

ILA07043

Test Circuit Diagram

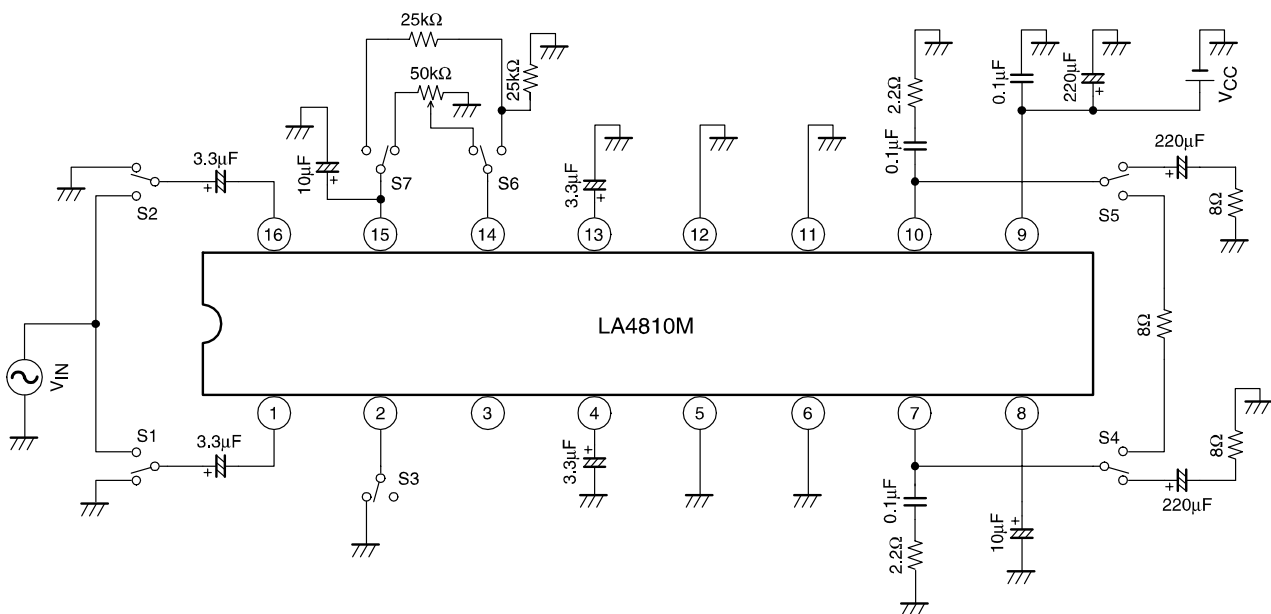

ILA07044

LA4810M

Application Circuit Example (Stereo Mode)

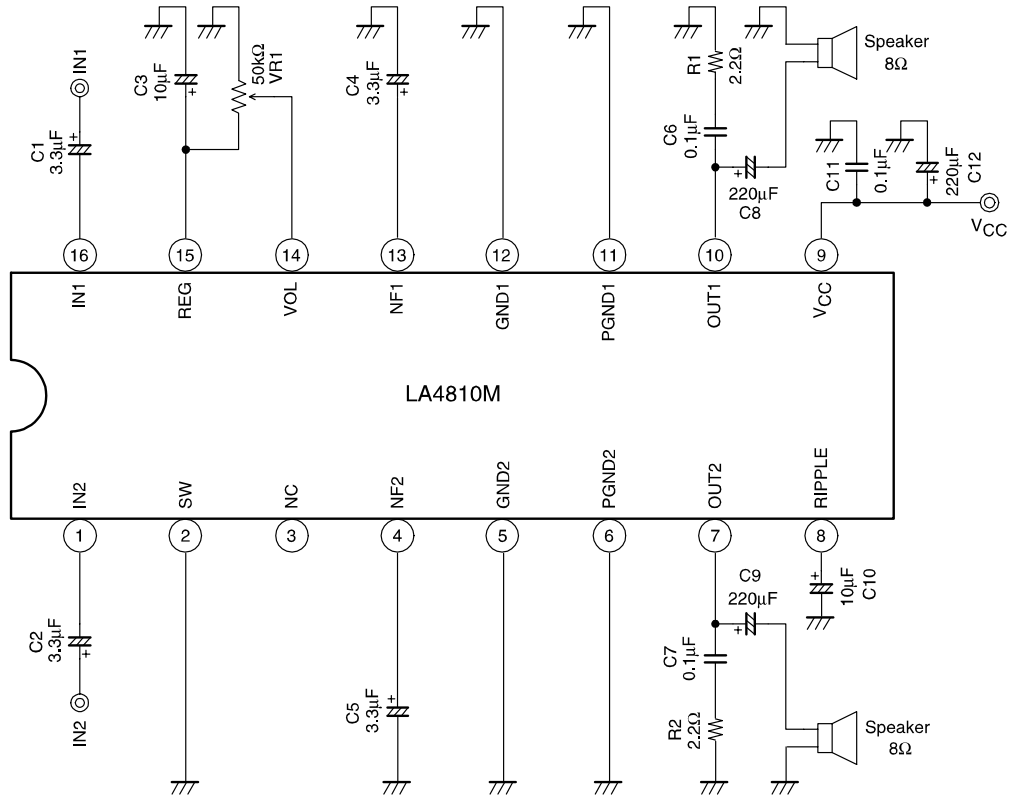

ILA07045

Application Circuit Example (BTL Mode)

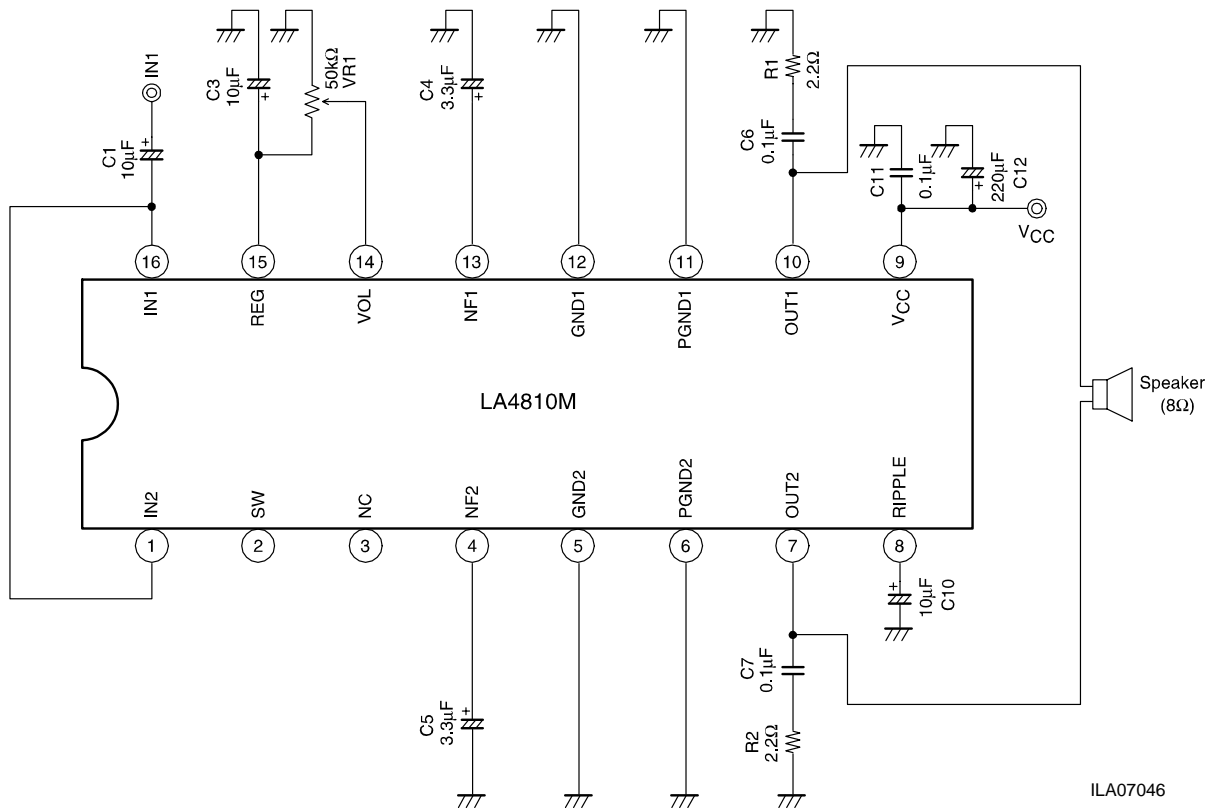

ILA07046

Operating Precautions

1. Electronic volume control (pin 14)

The voltage gain of the variable gain preamplifier can be changed by controlling the dc voltage at pin 14 (max. gain is approx. 13.5 dB). Pin 14 must be connected to GND when the internal electronic volume control is not to be used.

The recommended resistance of the external variable resistor is 20 k Ω or greater.

Maximum gain \rightarrow V14=0V (GND)

Minimum gain \rightarrow V14=1.25V (voltage at pin 15)

2. Stereo/BTL selector pin (pin 2)

The stereo and monaural BTL modes can be selected by controlling pin 2.

Stereo mode Pin 2 \rightarrow Connect to GND (or 0.3V or below).

BTL mode Pin 2 \rightarrow Keep open.

3. Phase compensation components (C6, R1, C7, and R2)

Note that the values of the phase compensation capacitors and resistors to be connected to the output pins (pins 7 and 10) vary depending on their print pattern.

C6, C7: 0.1 μ F or greater

R1, R2: 1.5 to 4.7 Ω

4. Power supply bypass capacitor (C11)

The bypass capacitor C11 must be placed as close to the power pin (pin 9) as possible.

5. Ground of the power amplifier output stage

Pins 6 and 11 serve as GND pins for the power amplifier output stage. Their print pattern must be designed so that the pins are kept as low in impedance as possible.

6. Short-circuit across pins

Turning on the IC with some of its pins short-circuited may cause characteristic deterioration of or fatal damage to the IC. After installing the IC on a board and before turning on power, make sure that its pins are not short-circuited by solder or other foreign materials.

7. Short-circuit of the load

Keeping the IC with its load short-circuited for an extended period of time may cause characteristic deterioration of or fatal damage to the IC. Never short-circuit the load of the IC.

8. Maximum ratings

It is likely that the maximum ratings of the IC may be exceeded on a slight change in operating conditions if the IC is used at or near its ratings. Since such a condition may lead to a fatal failure accident, allow for adequate margins for fluctuations in supply voltage and to make sure that the IC is used within its maximum ratings range.

LA4810M

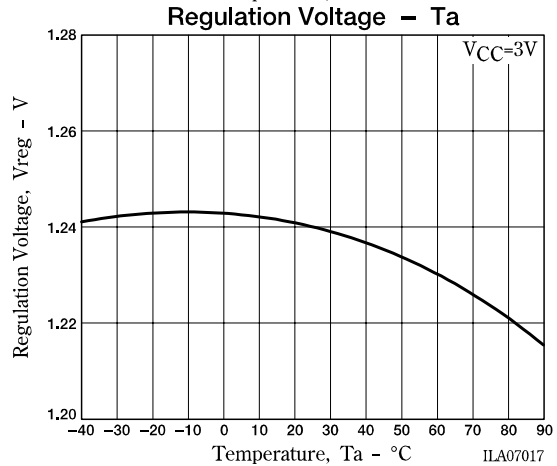
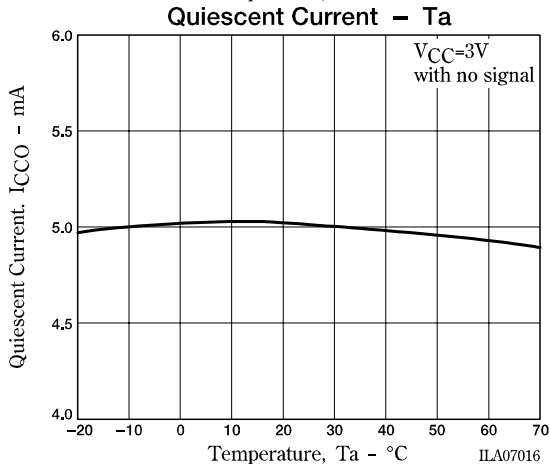
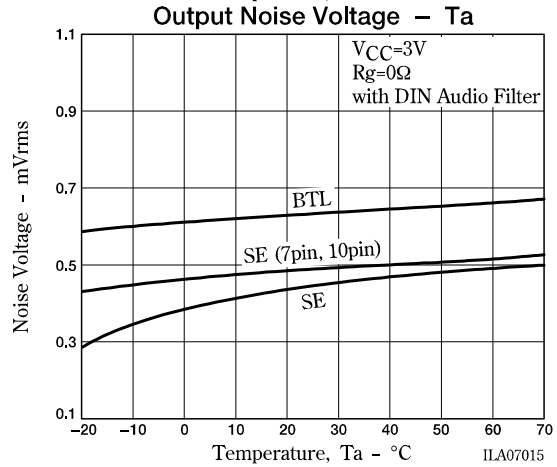
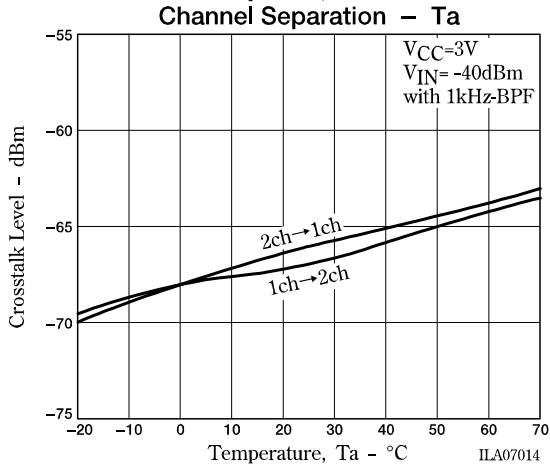
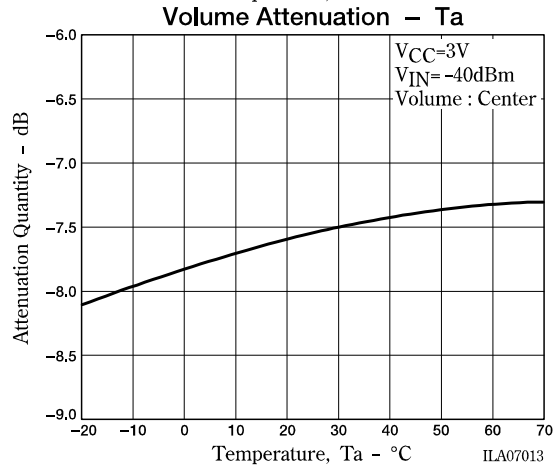
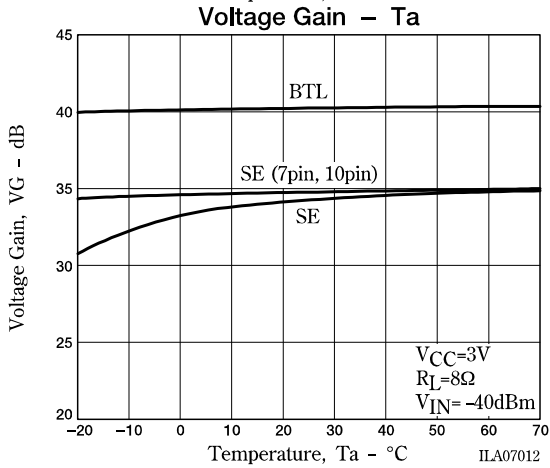
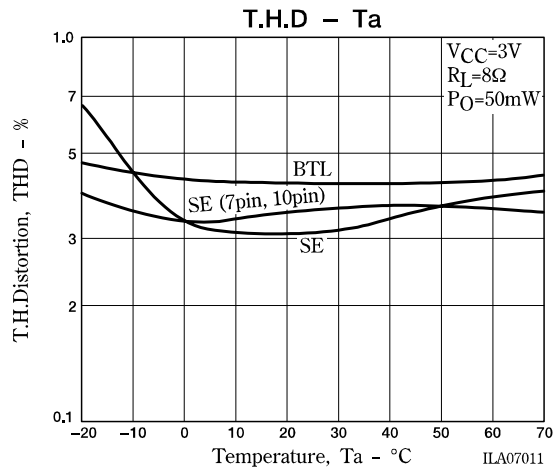
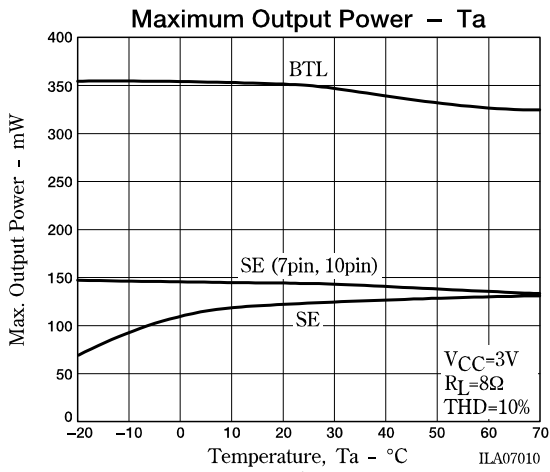

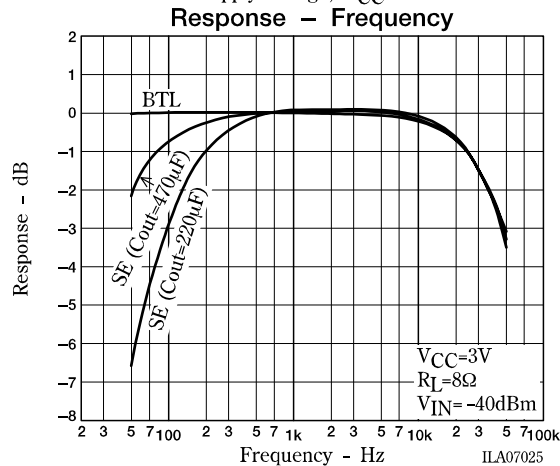
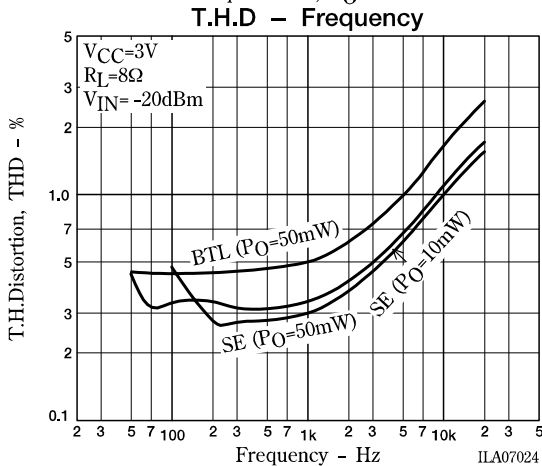
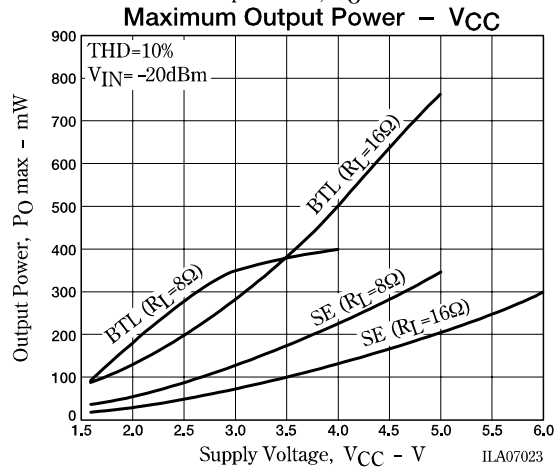
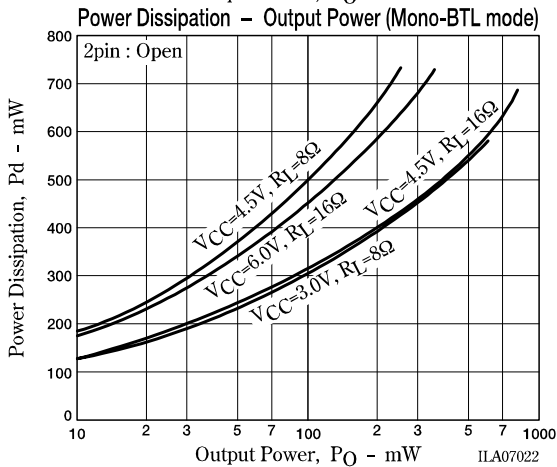
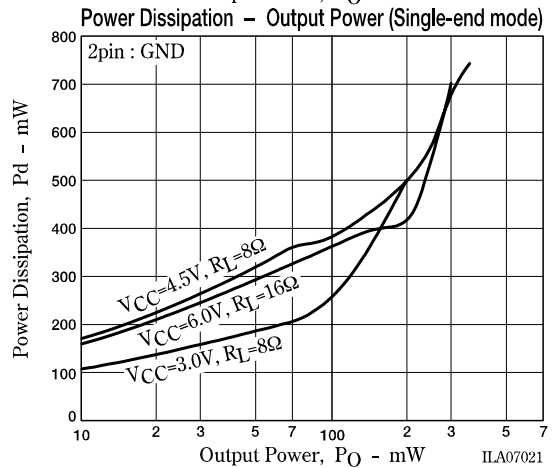
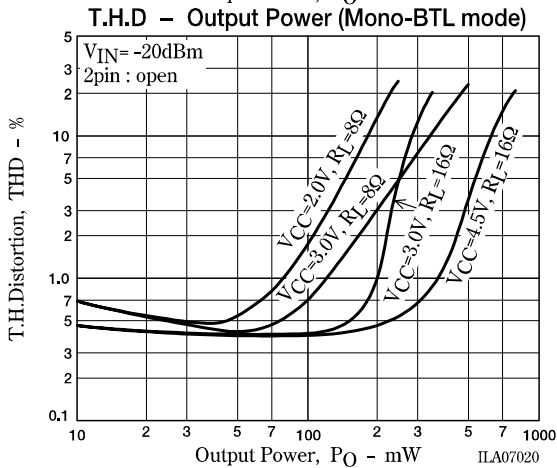
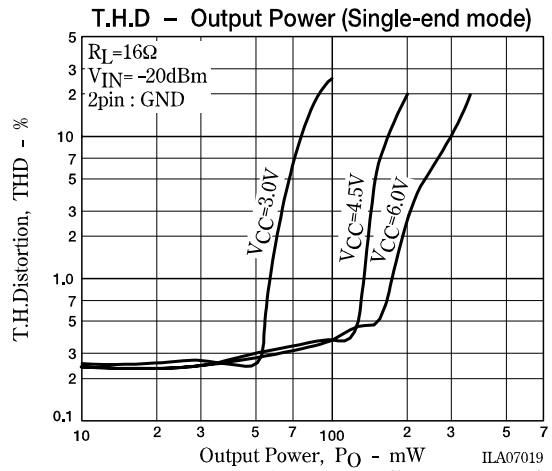
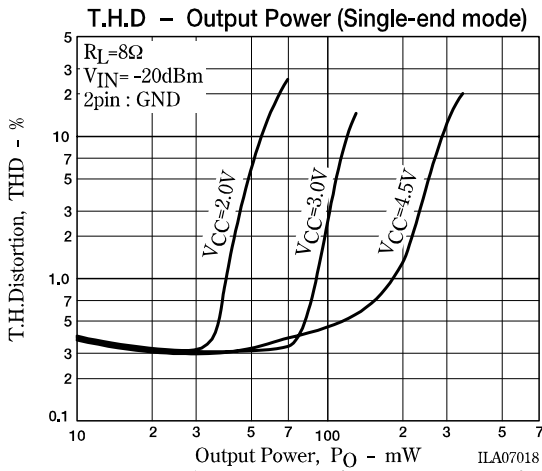

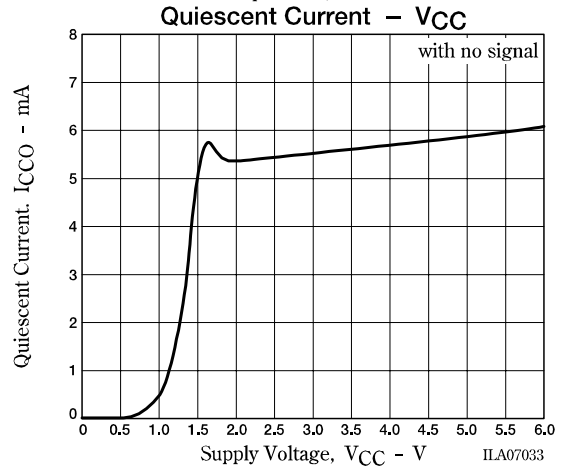
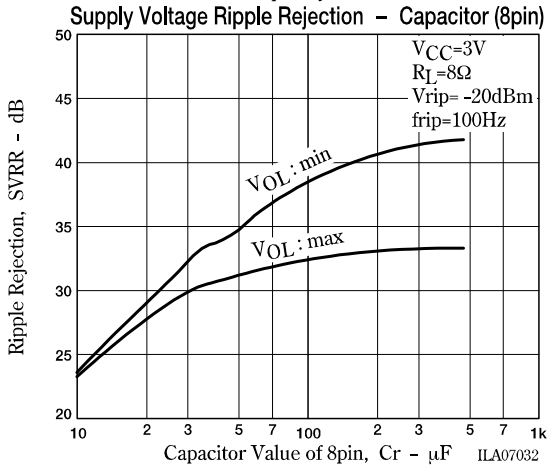
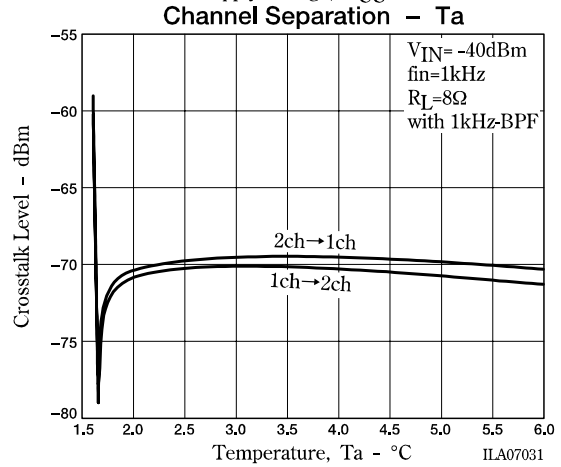
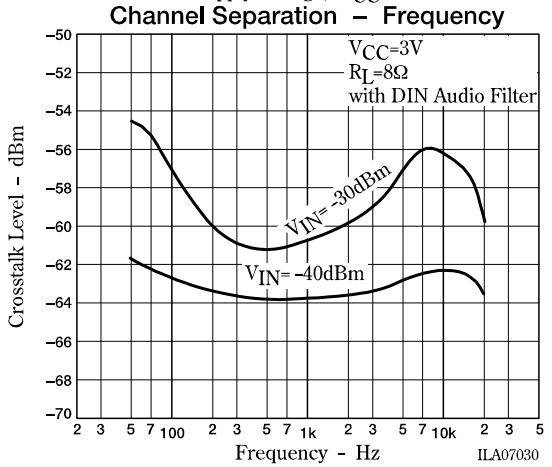
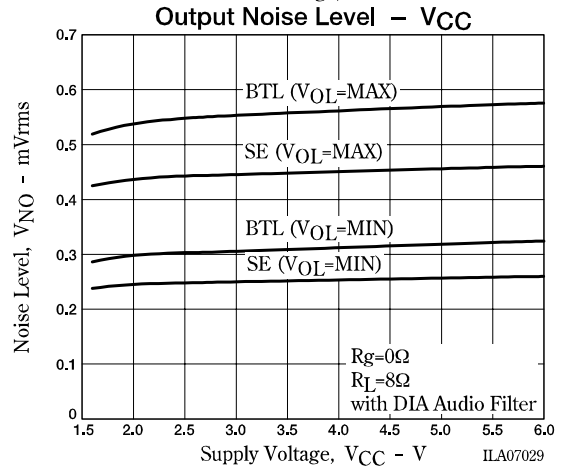
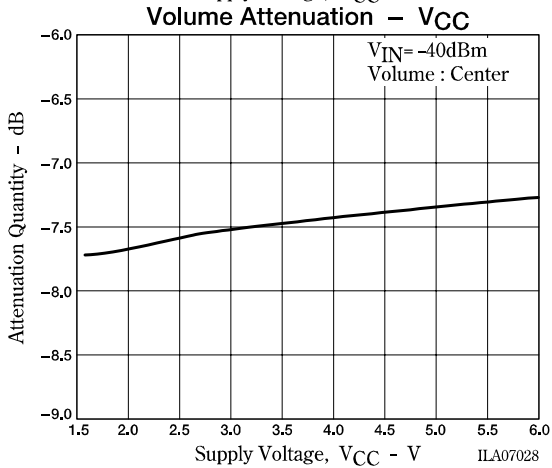
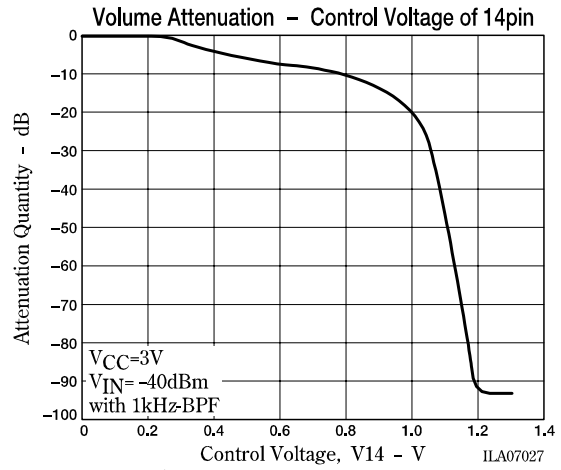
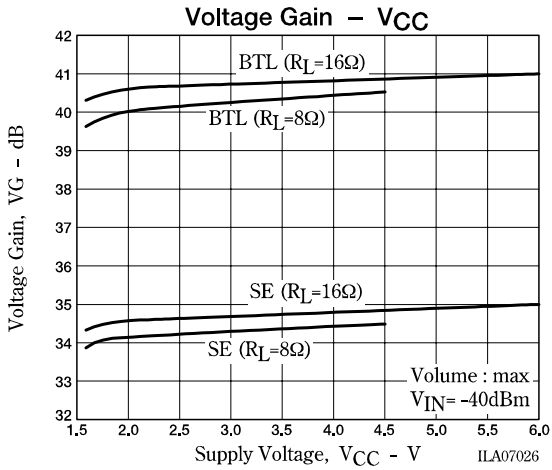

LA4810M

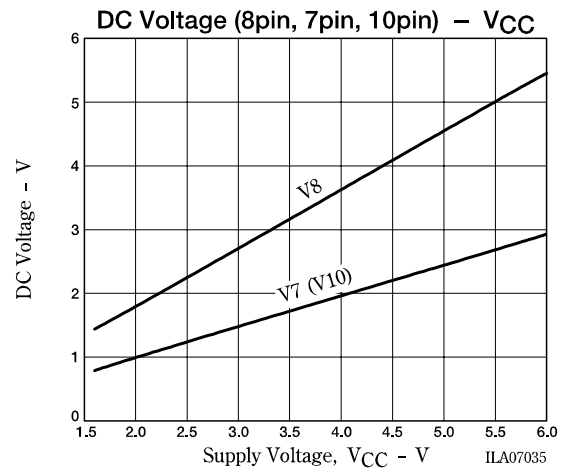
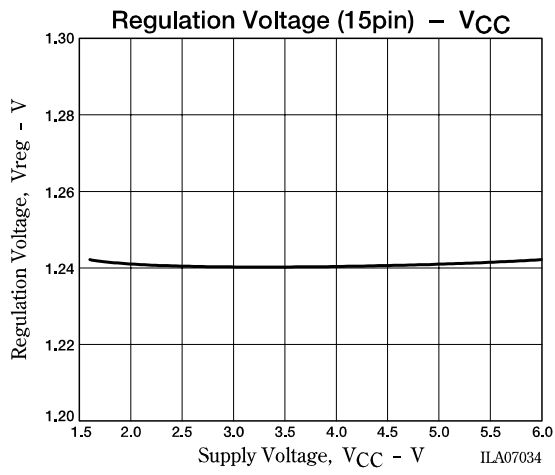

Package Dimensions

unit : mm
3035B

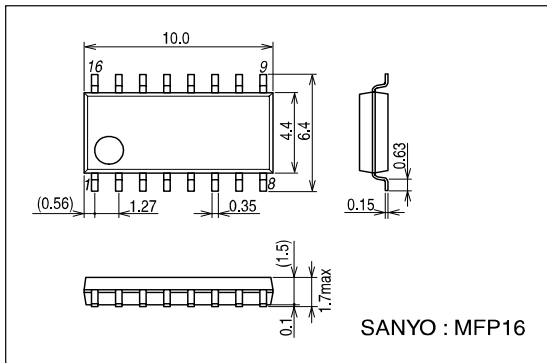

- Specifications of any and all SANYO Semiconductor products described or contained herein stipulate the performance, characteristics, and functions of the described products in the independent state, and are not guarantees of the performance, characteristics, and functions of the described products as mounted in the customer's products or equipment. To verify symptoms and states that cannot be evaluated in an independent device, the customer should always evaluate and test devices mounted in the customer's products or equipment.
- SANYO Semiconductor Co., Ltd. strives to supply high-quality high-reliability products. However, any and all semiconductor products fail with some probability. It is possible that these probabilistic failures could give rise to accidents or events that could endanger human lives, that could give rise to smoke or fire, or that could cause damage to other property. When designing equipment, adopt safety measures so that these kinds of accidents or events cannot occur. Such measures include but are not limited to protective circuits and error prevention circuits for safe design, redundant design, and structural design.
- In the event that any or all SANYO Semiconductor products (including technical data, services) described or contained herein are controlled under any of applicable local export control laws and regulations, such products must not be exported without obtaining the export license from the authorities concerned in accordance with the above law.
- No part of this publication may be reproduced or transmitted in any form or by any means, electronic or mechanical, including photocopying and recording, or any information storage or retrieval system, or otherwise, without the prior written permission of SANYO Semiconductor Co., Ltd.
- Any and all information described or contained herein are subject to change without notice due to product/technology improvement, etc. When designing equipment, refer to the "Delivery Specification" for the SANYO Semiconductor product that you intend to use.
- Information (including circuit diagrams and circuit parameters) herein is for example only; it is not guaranteed for volume production. SANYO Semiconductor believes information herein is accurate and reliable, but no guarantees are made or implied regarding its use or any infringements of intellectual property rights or other rights of third parties.

This catalog provides information as of June, 2005. Specifications and information herein are subject to change without notice.