



For Automotive I²C-BUS INTERFACE REAL TIME CLOCK MODULE

RA - 8565 SA

- Built in frequency adjusted 32.768 kHz crystal unit.
- Interface Type : I²C-Bus Interface (400 kHz)
- Wide operating voltage range : 1.8 V to 5.5 V
- Wide Timekeeper voltage range : 1.7 V to 5.5 V
- Extended operating temperature range: $T_a = -40\text{ }^\circ\text{C}$ to $+125\text{ }^\circ\text{C}$
- 32.768 kHz frequency output function: N-ch Open drain output With Control Pin
- The various functions include full calendar, alarm, timer, etc

* The I²C-Bus is a trademark of NXP Semiconductors



Actual size



Block diagram

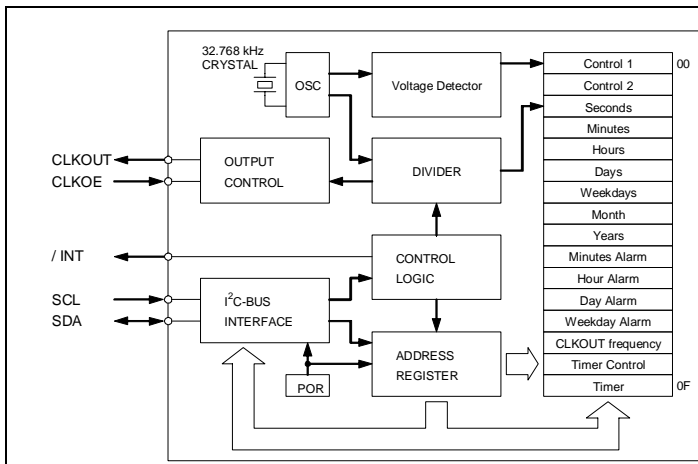

Overview

- Wide operating temperature range for automotive
 - $-40\text{ }^\circ\text{C}$ to $+125\text{ }^\circ\text{C}$
- Clocking-status detection function
 - It can judge the validity of data after backup operation return by a status of VL-bit.
- 32.768kHz frequency output function
 - CLKOUT pin output (N-ch Open Drain output)
 - Output frequency can be selected as 32.768kHz, 1024Hz, 32Hz, or 1Hz.
- The various interrupt function
 - Timer function can be set up between 1/4096 second and 255 minutes.
 - Alarm function can be set to day of week, day, hour, or minute.

Pin Function

Terminal	Directions	Functions
SCL	Input	Serial clock input.
SDA	Bi-directional	Data input and output.
CLKOUT	Output	The CLKOUT pin is a clock output (open drain output) pin with control output. (Output frequency can be selected as 32.768 kHz, 1024 Hz, 32 Hz, or 1 Hz.) The CLKOE pin is an input pin used to control the output mode of the CLKOUT output pin.
CLKOE	Input	During the initial power-on (when power is applied from 0 V) , if the CLKOE input pin is at high level (= H) , the power-on reset function selects 32.768 kHz as the frequency.
/INT	Output	Interrupts output by Alarm and Timer events. (Open drain output)
V _{DD}	-	Connected to a positive power supply.
GND	-	Connected to a ground.

Terminal connection / External dimensions

(Unit:mm)

RA - 8565 SA

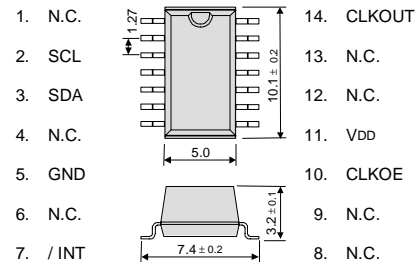

SOP - 14 pin

Metal may be exposed on the top or bottom of this product. This will not affect any quality, reliability or electrical spec.

Specifications (characteristics)

* Refer to application manual for details.

Recommended Operating Conditions

Item	Symbol	Conditions	Min.	Typ.	Max.	unit
Operating voltage	V _{DD}	-	1.8	3.0	5.5	V
Timekeeper voltage	V _{CLK}	-	1.7	3.0	5.5	V
Operating temperature	TOPR	-	-40	+25	+125	°C

Frequency characteristics

Item	Symbol	Conditions	Rating	unit
Frequency stability	$\Delta f / f$	$T_a = +25\text{ }^\circ\text{C}$ V _{DD} = 3.0 V	$5 \pm 23^{*1}$	$\times 10^{-6}$
Oscillation start up time	t _{STA}	$T_a = +25\text{ }^\circ\text{C}$ V _{DD} = 1.8 V	1.5 Max.	s
		$T_a = -40\text{ }^\circ\text{C}$ to $+125\text{ }^\circ\text{C}$ V _{DD} = 3.0 V	3 Max.	s

*1) Equivalent to 1 minutes of monthly deviation.

Current consumption under backup mode.

Item	Symbol	Conditions	Min.	Typ.	Max.	unit
Standby current.	I _{BK}	f _{SCL} = 0 Hz CLKOE = LOW	T _a = +125 °C	0.95	1.80	μA
			T _a = +25 °C	0.60		
		f _{SCL} = 0 Hz CLKOE = LOW	T _a = +125 °C	0.80	1.60	μA
			T _a = +25 °C	0.55		