

FEATURES

ADV478/ADV471 (ADV[®]) Register Level Compatible
 IBM PS/2,* VGA*/XGA* Compatible
 135 MHz Pipelined Operation
 Triple 8-Bit D/A Converters
 Triple 256 × 8 (256 × 24) Color Palette RAM
 Three 15 × 8 Overlay Registers
 On-Board Voltage Reference
 RS-343A/RS-170 Compatible Analog Outputs
 TTL Compatible Digital Inputs and Outputs
 Sync on All Three Channels
 Programmable Pedestal (0 or 7.5 IRE)
 Standard MPU I/O Interface
 +5 V CMOS Monolithic Construction
 68-Pin PLCC Package

APPLICATIONS

High Resolution Color Graphics
 True-Color Visualization
 CAE/CAD/CAM
 Image Processing
 Desktop Publishing

MODES

24-Bit True Color
 8-Bit Pseudo Color
 15-Bit True Color
 8-Bit True Color

SPEED GRADES

135 MHz, 110 MHz
 80 MHz, 66 MHz

GENERAL DESCRIPTION

The ADV473 is a complete analog output, Video RAM-DAC on a single CMOS monolithic chip. The part is specifically designed for true-color computer graphics systems.

The ADV473 integrates a number of graphic functions onto one device allowing 24-bit direct true-color operation at the maximum screen update rate of 135 MHz. It can also be used in other modes, including 15-bit true color and 8-bit pseudo or indexed color. The ADV473 is fully PS/2 and VGA register level compatible. It is also capable of implementing IBM's XGA standard.

(Continued on page 4)

FUNCTIONAL BLOCK DIAGRAM

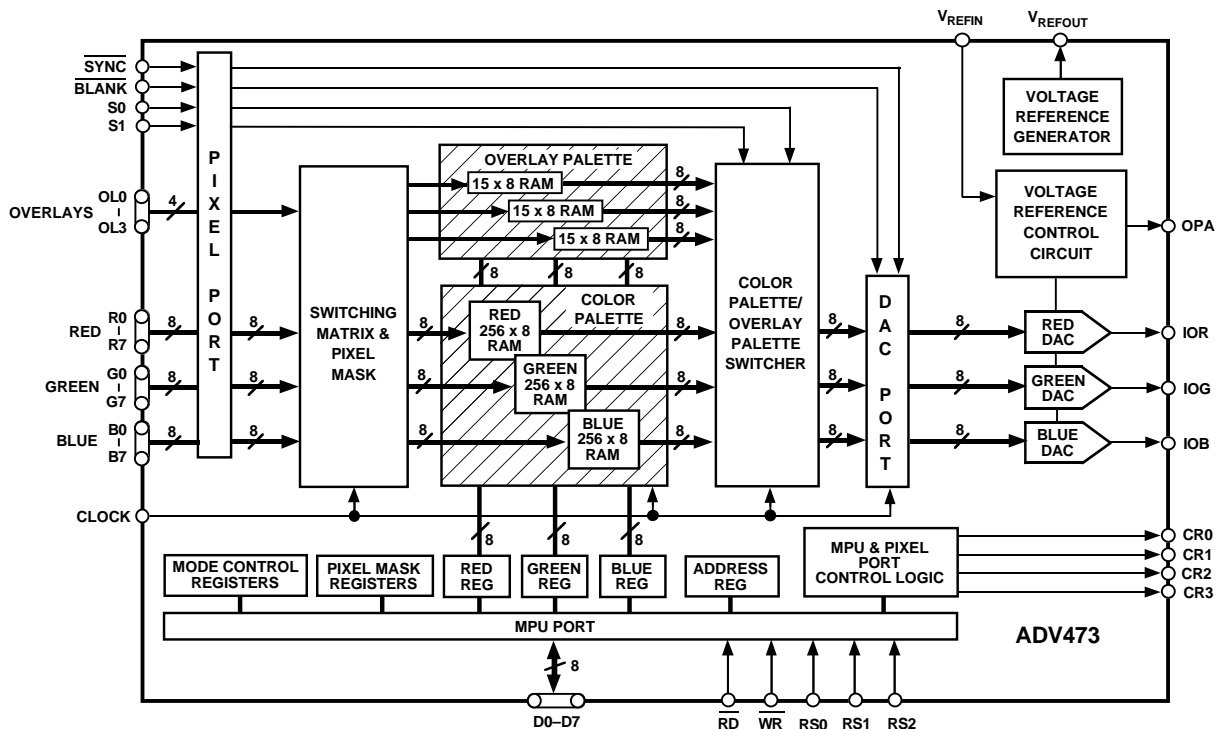

ADV is a registered trademark of Analog Devices Inc.

*Personal System/2 and VGA are trademarks of International Business Machines Corp.

REV. A

Information furnished by Analog Devices is believed to be accurate and reliable. However, no responsibility is assumed by Analog Devices for its use, nor for any infringements of patents or other rights of third parties which may result from its use. No license is granted by implication or otherwise under any patent or patent rights of Analog Devices.

One Technology Way, P.O. Box 9106, Norwood, MA 02062-9106, U.S.A.
 Tel: 617/329-4700 Fax: 617/326-8703

ADV473—SPECIFICATIONS

($V_{AA}^1 = 5\text{ V}$; $V_{REF} = 1.235\text{ V}$; $R_L = 37.5\ \Omega$, $C_L = 10\text{ pF}$; $R_{SET} = 140\ \Omega$. All specifications T_{MIN} to T_{MAX}^2 unless otherwise noted.)

Parameter	All Versions	Units	Test Conditions/Comments
STATIC PERFORMANCE			
Resolution (Each DAC)	8	Bits	
Accuracy (Each DAC)			
Integral Nonlinearity	± 1	LSB max	Guaranteed Monotonic External Reference Internal Reference
Differential Nonlinearity	± 1	LSB max	
Gray Scale Error	± 5	% Gray Scale	
Coding	± 10	% Gray Scale	
		Binary	
DIGITAL INPUTS			
Input High Voltage, V_{INH}	2	V min	$V_{IN} = 0.4\text{ V}$ or 2.4 V $f = 1\text{ MHz}$, $V_{IN} = 2.4\text{ V}$
Input Low Voltage, V_{INL}	0.8	V max	
Input Current, I_{IN}	± 1	μA max	
Input Capacitance, C_{IN}	7	pF max	
DIGITAL OUTPUTS			
Output High Voltage, V_{OH}	2.4	V min	$I_{SOURCE} = 400\ \mu\text{A}$ $I_{SINK} = 3.2\text{ mA}$
Output Low Voltage, V_{OL}	0.4	V max	
Floating-State Leakage Current	50	μA max	
Floating-State Leakage Capacitance	7	pF max	
ANALOG OUTPUTS			
Gray Scale Current Range	20	mA max	
Output Current			
White Level Relative to Black	16.74	mA min	Typically 17.62 mA
	18.50	mA max	
Black Level Relative to Blank	0.95	mA min	Typically 1.44 mA
(Pedestal = 7.5 IRE)	1.90	mA max	
Black Level Relative to Blank	0	μA min	Typically 5 μA
(Pedestal = 0 IRE)	50	μA max	
Blank Level	6.29	mA min	Typically 7.62 mA
	8.96	mA max	
Sync Level	0	μA min	Typically 5 μA
	50	μA max	
LSB Size	69.1	μA typ	
DAC-to-DAC Matching	2	% max	Typically 1%
Output Compliance, V_{OC}	0	V min	
	+1.5	V max	
Output Capacitance, C_{OUT}	30	pF max	$f = 1\text{ MHz}$, $I_{OUT} = 0\text{ mA}$
Output Impedance, R_{OUT}	10	k Ω typ	
VOLTAGE REFERENCE			
Internal Voltage Reference (V_{REFOUT})	1.08/1.32	V min/V max	Typically 1.235 V
External Voltage Reference Range	1.14/1.26	V min/V max	Typically 1.235 V
Input Current, I_{VREF} (Internal Reference)	100	μA typ	
Input Current (External Reference)	10	μA typ	
POWER SUPPLY			
Supply Voltage, V_{AA}	4.75/5.25	V min/V max	
Supply Current, I_{AA}^3	400	mA max	135 MHz Parts
	300	mA max	110 MHz Parts
	250	mA max	80 MHz Parts
	200	mA max	66 MHz Parts
DYNAMIC PERFORMANCE			
Clock and Data Feedthrough ^{4,5}	-30	dB typ	
Glitch Impulse ^{4,5}	75	pV secs typ	
DAC-to-DAC Crosstalk ⁶	-23	dB typ	

NOTES

¹ $V_{AA} = 5\text{ V} \pm 5\%$

²Temperature range (T_{MIN} to T_{MAX}); 0°C to $+70^\circ\text{C}$; T_J (Silicon Junction Temperature) $\leq 100^\circ\text{C}$.

³Pixel Port is continuously clocked with data corresponding to a linear ramp.

⁴Clock and data feedthrough is a function of the amount of overshoot and undershoot on the digital inputs. Glitch impulse includes clock and data feedthrough.

⁵TTL input values are 0 to 3 volts, with input rise/fall times $\leq 3\text{ ns}$, measured at the 10% and 90% points. Timing reference points at 50% for inputs and outputs.

⁶DAC to DAC Crosstalk is measured by holding one DAC high while the other two are making low to high and high to low transitions.

Specifications subject to change without notice.

TIMING CHARACTERISTICS¹ ($V_{AA}^2 = 5\text{ V}$; $V_{REF} = 1.235\text{ V}$; $R_L = 37.5\ \Omega$, $C_L = 10\text{ pF}$; $R_{SET} = 140\ \Omega$. All specifications T_{MIN} to T_{MAX} ³ unless otherwise noted.)

Parameter	135 MHz Version	110 MHz Version	80 MHz Version	66 MHz Version	Units	Conditions/Comments
fmax	135	110	80	66	MHz	Clock Rate
t ₁	10	10	10	10	ns min	RS0–RS2 Setup Time
t ₂	10	10	10	10	ns min	RS0–RS2 Hold Time
t ₃ ⁴	3	3	3	3	ns min	\overline{RD} Asserted to Data Bus Driven
t ₄ ⁴	40	40	40	40	ns max	\overline{RD} Asserted to Data Valid
t ₅ ⁵	20	20	20	20	ns max	\overline{RD} Negated to Data Bus 3-States
t ₆ ⁵	5	5	5	5	ns min	Read Data Hold Time
t ₇	10	10	10	10	ns min	Write Data Setup Time
t ₈	10	10	10	10	ns min	Write Data Hold Time
t ₉	100	100	100	100	ns max	CR0–CR3 Delay Time
t ₁₀	50	50	50	50	ns min	\overline{RD} , \overline{WR} Pulse Width Low
t ₁₁	40	40	40	40	ns min	\overline{RD} , \overline{WR} Pulse Width High
t ₁₂	2	3	3	3	ns min	Pixel & Control Setup Time
t ₁₃	2	3	3	3	ns min	Pixel & Control Hold Time
t ₁₄	7.4	9.1	12.5	15.15	ns min	Clock Cycle Time
t ₁₅	3	3.5	4	5	ns min	Clock Pulse Width High Time
t ₁₆	2	3	4	5	ns min	Clock Pulse Width Low Time
t ₁₇	30	30	30	30	ns max	Analogue Output Delay
t ₁₈	3	3	3	3	ns typ	Analogue Output Rise/Fall Time
t ₁₉ ⁶	13	13	13	13	ns max	Analogue Output Settling Time
t _{SK}	2	2	2	2	ns max	Analogue Output Skew
t _{PD}	4 × t ₁₄	4 × t ₁₄	4 × t ₁₄	4 × t ₁₄	ns	Pipeline Delay

NOTES

¹TTL input values are 0 to 3 volts, with input rise/fall times ≤ 3 ns, measured between the 10% and 90% points. Timing reference points at 50% for inputs and outputs. Analog output load ≤ 10 pF, D0-D7 output load ≤ 50 pF. See timing notes in Figure 2.

²V_{AA} = 5 V ± 5%.

³Temperature range (T_{MIN} to T_{MAX}); 0°C to +70°C; T_J (Silicon Junction Temperature) ≤ 100°C.

⁴t₃ and t₄ are measured with the load circuit of Figure 3 and defined as the time required for an output to cross 0.4 V or 2.4 V.

⁵t₅ and t₆ are derived from the measured time taken by the data outputs to change by 0.5 V when loaded with the circuit of Figure 3. The measured number is then extrapolated back to remove the effects of charging the 50 pF capacitor. This means that the times, t₅ and t₆, quoted in the timing characteristics are the true values for the device and, as such, are independent of external bus loading capacitances.

⁶Settling time does not include clock and data feedthrough.

Specifications subject to change without notice.

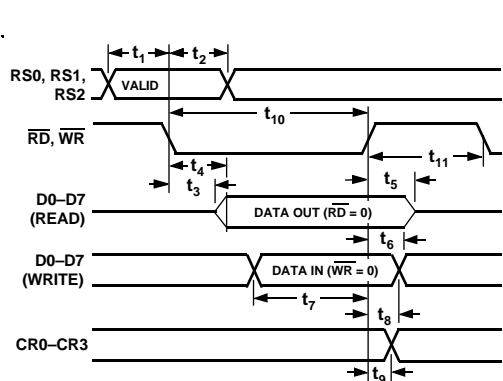
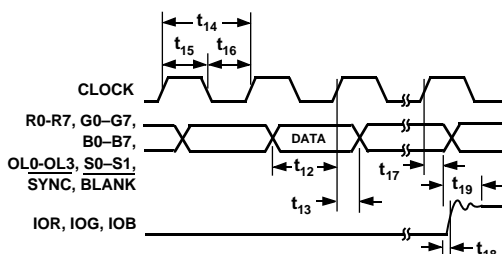

Figure 1. MPU Read/Write Timing



NOTES

1. OUTPUT DELAY MEASURED FROM THE 50% POINT OF THE RISING EDGE OF CLOCK TO THE 50% POINT OF FULL-SCALE TRANSITION.
2. SETTLE TIME MEASURED FROM THE 50% POINT OF FULL-SCALE TRANSITION TO THE OUTPUT REMAINING WITHIN ±1 LSB.
3. OUTPUT RISE/FALL TIME MEASURED BETWEEN THE 10% AND 90% POINTS OF FULL-SCALE TRANSITION.

Figure 2. Video Input/Output Timing

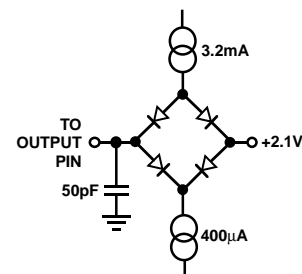

Figure 3. Load Circuit for Bus Access and Relinquish Time

ADV473

RECOMMENDED OPERATING CONDITIONS

Parameter	Symbol	Min	Typ	Max	Units
Power Supply	V _{AA}	4.75	5.00	5.25	Volts
Ambient Operating Temperature	T _A	0		+70	°C
Output Load	R _L		37.5		Ω
Reference Voltage	V _{REF}	1.14	1.235	1.26	Volts

ABSOLUTE MAXIMUM RATINGS¹

V_{AA} to GND 7 V
 Voltage on Any Digital Pin GND - 0.5 V to V_{AA} + 0.5 V
 Ambient Operating Temperature (T_A) -55°C to +125°C
 Storage Temperature (T_S) -65°C to +150°C
 Junction Temperature (T_J) +150°C
 Lead Temperature (Soldering, 10 secs) +300°C
 Vapor Phase Soldering (2 minutes) +220°C
 IOR, IOG, IOB to GND² GND-0.5 V to V_{AA}

NOTES

¹Stresses above those listed under "Absolute Maximum Ratings" may cause permanent damage to the device. This is a stress rating only and functional operation of the device at these or any other conditions above those listed in the operational sections of this specification is not implied. Exposure to absolute maximum rating conditions for extended periods may affect device reliability.

²Analog output short circuit to any power supply or common can be of an indefinite duration.

ORDERING GUIDE

Model	Speed	Temperature Range	No. of Pins	Package Option*
ADV473KP135	135 MHz	0°C to +70°C	68	P-68A
ADV473KP110	110 MHz	0°C to +70°C	68	P-68A
ADV473KP80	80 MHz	0°C to +70°C	68	P-68A
ADV473KP66	66 MHz	0°C to +70°C	68	P-68A

NOTE

*All devices are packaged in a 68-pin plastic leaded (J-lead) chip carrier.

CAUTION

ESD (electrostatic discharge) sensitive device. Electrostatic charges as high as 4000 V readily accumulate on the human body and test equipment and can discharge without detection. Although the ADV473 features proprietary ESD protection circuitry, permanent damage may occur on devices subjected to high energy electrostatic discharges. Therefore, proper ESD precautions are recommended to avoid performance degradation or loss of functionality.



(Continued from page 1)

The device consists of three, high speed, 8-bit, video D/A converters (RGB), a 256 × 24 RAM which can be configured as a look-up table or a linearization RAM, a 24-bit wide parallel pixel input port and three 15 × 8 overlay registers. The part is controlled through the MPU port by the various on-board control/command registers.

The individual red, green and blue pixel input ports allow true-color, image rendition. True-color image rendition, at speeds of up to 135 MHz, is achieved through the 24-bit pixel input port. The ADV473 is also capable of implementing 8-bit true color, 8-bit pseudo color and 15-bit true color.

PIN CONFIGURATION 68-Pin PLCC

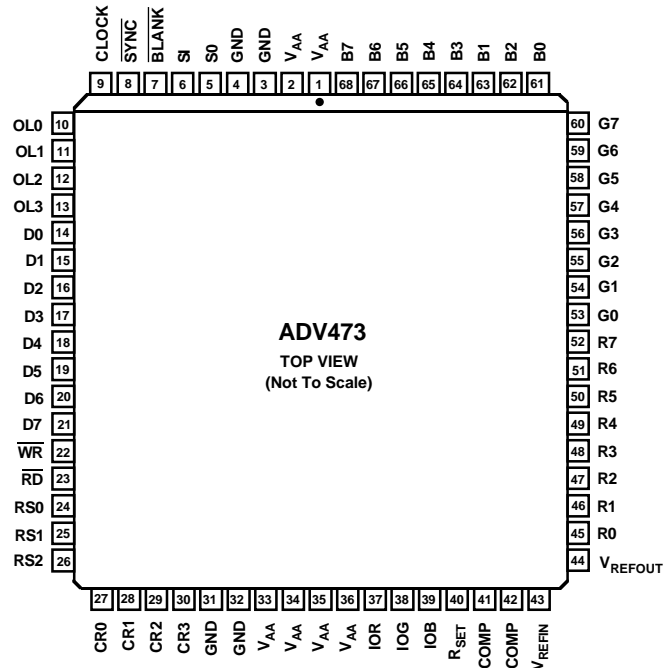

PIN FUNCTION DESCRIPTION

$\overline{\text{BLANK}}$	Composite Blank Control Input (TTL Compatible). A logic zero drives the analog outputs to the blanking level. It is latched on the rising edge of CLOCK. When $\overline{\text{BLANK}}$ is a logical zero, the pixel and overlay inputs are ignored.
$\overline{\text{SYNC}}$	Composite SYNC Control Input (TTL Compatible). A logical zero on this input switches off a 40 IRE current source on the analog outputs. $\overline{\text{SYNC}}$ does not override any other control or data input; therefore, it should be asserted only during the blanking interval. It is latched on the rising edge of CLOCK. If sync information is not required on the analog outputs, $\overline{\text{SYNC}}$ should be connected to ground.
CLOCK	Clock Input (TTL Compatible). The rising edge of CLOCK latches the R0–R7, G0–G7, B0–B7, S0, S1, OL0–OL3, $\overline{\text{SYNC}}$, and $\overline{\text{BLANK}}$ inputs. It is typically the pixel clock rate of the video system. It is recommended that CLOCK be driven by a dedicated TTL buffer.
R0–R7 B0–B7 G0–G7	Red, Green and Blue Select Inputs (TTL Compatible). These inputs specify, on a pixel basis, the color value to be written to the DACs. They are latched on the rising edge of CLOCK. R0, G0 and B0 are the LSBs. Unused inputs should be connected to GND.
S0, S1	Color Mode Select Inputs (TTL Compatible). These inputs specify the mode of operation as shown in Table III. They are latched on the rising edge of CLOCK.
OL0–OL3	Overlay Select Inputs (TTL Compatible). These inputs specify which palette is to be used to provide color information. When accessing the overlay palette, the R0–R7, G0–G7, B0–B7, S0 and S1 inputs are ignored. They are latched on the rising edge of CLOCK. OL0 is the LSB. Unused inputs should be connected to GND.
IOR, IOG, IOB	Red, Green, and Blue Current Outputs. These high impedance current sources are capable of directly driving a doubly terminated 75 Ω coaxial cable.
R _{SET}	Full-Scale Adjust Resistor. A resistor (R _{SET}) connected between this pin and GND controls the magnitude of the full-scale video signal. The relationship between R _{SET} and the full-scale output current on each output is: $R_{\text{SET}} (\Omega) = 3,195 \times V_{\text{REF}} (\text{V}) / I_{\text{OUT}} (\text{mA}) \text{ SETUP} = 7.5 \text{ IRE}$ $R_{\text{SET}} (\Omega) = 3,025 \times V_{\text{REF}} (\text{V}) / I_{\text{OUT}} (\text{mA}) \text{ SETUP} = 0 \text{ IRE}$
COMP	Compensation Pin. These pins should be connected together at the chip and connected through 0.1 μF ceramic capacitor to V _{AA} .
V _{REFIN}	Voltage Reference Input. This input requires a 1.2 V reference voltage. This is achieved through the on-board voltage reference generator by connecting V _{REFOUT} to V _{REFIN} . If an external reference is used, it must supply this input with a 1.2 V (typical) reference.
V _{REFOUT}	Voltage Reference Output. This output delivers a 1.2 V reference voltage from the device's on-board voltage reference generator. It is normally connected directly to the V _{REFIN} pin. If it is preferred to use an external voltage reference, this pin may be left floating. Up to four ADV473s can be driven from V _{REFOUT} .
V _{AA}	Analog power. All V _{AA} pins must be connected.
GND	Analog Ground. All GND pins must be connected.
$\overline{\text{WR}}$	Write Control Input (TTL Compatible). D0–D7 data is latched on the rising edge of $\overline{\text{WR}}$, and RS0–RS2 are latched on the falling edge of $\overline{\text{WR}}$ during MPU write operations. $\overline{\text{RD}}$ and $\overline{\text{WR}}$ should not be asserted simultaneously.
$\overline{\text{RD}}$	Read Control Input (TTL Compatible). To read data from the device, $\overline{\text{RD}}$ must be a logical zero. RS0–RS2 are latched on the falling edge of $\overline{\text{RD}}$ during MPU read operations. $\overline{\text{RD}}$ and $\overline{\text{WR}}$ should not be asserted simultaneously.
RS0, RS1, RS2	Register Select Inputs (TTL Compatible). RS0–RS2 specify the type of read or write operation being performed.
D0–D7	Data Bus (TTL Compatible). Data is transferred into and out of the device over this eight-bit bidirectional data bus. D0 is the least significant bit.
CR0–CR7	Control Outputs (TTL Compatible). These outputs are used to control application specific features. The output values are determined by the contents of the command register (CR).

ADV473

TERMINOLOGY

BLANKING LEVEL

The level separating the $\overline{\text{SYNC}}$ portion from the video portion of the waveform. Usually referred to as the front porch or back porch. At 0 IRE units, it is the level which will shut off the picture tube, resulting in the blackest possible picture.

COLOR VIDEO (RGB)

This usually refers to the technique of combining the three primary colors of red, green and blue to produce color pictures within the usual spectrum. In RGB monitors, three DACs are required, one for each color.

COMPOSITE $\overline{\text{SYNC}}$ SIGNAL ($\overline{\text{SYNC}}$)

The position of the composite video signal which synchronizes the scanning process.

COMPOSITE VIDEO SIGNAL

The video signal with or without setup, plus the composite $\overline{\text{SYNC}}$ signal.

GRAY SCALE

The discrete levels of video signal between reference black and reference white levels. An 8-bit DAC contains 256 different levels while a 6-bit DAC contains 64.

RASTER SCAN

The most basic method of sweeping a CRT one line at a time to generate and to display images.

REFERENCE BLACK LEVEL

The maximum negative polarity amplitude of the video signal.

REFERENCE WHITE LEVEL

The maximum positive polarity amplitude of the video signal.

SETUP

The difference between the reference black level and the blanking level.

$\overline{\text{SYNC}}$ LEVEL

The peak level of the composite $\overline{\text{SYNC}}$ signal.

VIDEO SIGNAL

That portion of the composite video signal which varies in gray scale levels between reference white and reference black. Also referred to as the picture signal, this is the portion which may be visually observed.

CIRCUIT DESCRIPTION

MPU Interface

The ADV473 supports a standard MPU bus interface, allowing the MPU direct access to the color palette RAM and overlay color registers.

Three address decode lines, RS0–RS2, specify whether the MPU is accessing the address register, the color palette RAM, the overlay registers, or read mask register. These controls also determine whether this access is a read or write function. Table I illustrates this decoding. The 8-bit address register is used to address the contents of the color palette RAM and overlay registers.

Table I. Control Input Truth Table

RS2	RS1	RS0	Addressed by MPU
0	0	0	Address Register (RAM Write Mode)
0	1	1	Address Register (RAM Read Mode)
0	0	1	Color Palette RAM
0	1	0	Pixel Read Mask Register
1	0	0	Address Register (Overlay Write Mode)
1	1	1	Address Register (Overlay Read Mode)
1	0	1	Overlay Registers
1	1	0	Command Register

Color Palette Writes

The MPU writes to the address register (selecting RAM write mode, RS2 = 0, RS1 = 0 and RS0 = 0) with the address of the color palette RAM location to be modified. The MPU performs three successive write cycles (8 or 6 bits each of red, green, and blue), using RS0–RS2 to select the color palette RAM (RS2 = 0, RS1 = 0, RS0 = 1). After the BLUE write cycle, the three bytes of color information are concatenated into a 24-bit word or an 18-bit word and written to the location specified by the address register. The address register then increments to the next location which the MPU may modify by simply writing another sequence of red, green, and blue data. A complete set of colors can be loaded into the palette by initially writing the start address and then performing a sequence of RED, GREEN and BLUE writes. The address automatically increments to the next highest location after a BLUE write.

Color Palette Reads

The MPU writes to the address register (selecting RAM read mode, RS2 = 0, RS1 = 1 and RS0 = 1) with the address of the color palette RAM location to be read back. The contents of the palette RAM are copied to the RED, GREEN and BLUE registers and the address register increments to point to the next palette RAM location. The MPU then performs three successive read cycles (8 or 6 bits each of red, green, and blue), using RS0–RS2 to select the color palette RAM (RS2 = 0, RS1 = 0, RS0 = 1). After the BLUE read cycle, the 24/18 bit contents of the palette RAM at the location specified by the address register is loaded into the RED, GREEN and BLUE registers. The address register then increments to the next location which the MPU can read back by simply reading another sequence of red, green, and blue data. A complete set of colors can be read back from the palette by initially writing the start address and then performing a sequence of RED, GREEN and BLUE reads. The address automatically increments to the next highest location after a BLUE read.

Table II. Address Register (ADDR) Operation

	Value	RS2	RS1	RS0	Addressed by MPU
ADDRa,b (Counts Modulo 3)	00	X	0	1	Red Value
	01	X	0	1	Green Value
	10	X	0	1	Blue Value
ADDR0-7 (Counts Binary)	00H–FFH	0	0	1	Color Palette RAM
	XXXX 0000	1	0	1	Reserved
	XXXX 0001	1	0	1	Overlay Color 1
	XXXX 0010	1	0	1	Overlay Color 2
	•	•	•	•	•
	•	•	•	•	•
	XXXX 1111	1	0	1	Overlay Color 15

Overlay Color Writes

The MPU writes to the address register (selecting OVERLAY REGISTER write mode, RS2 = 1, RS1 = 0 and RS0 = 0) with the address of the overlay register to be modified. The MPU performs three successive write cycles (8 or 6 bits each of red, green, and blue), using RS0–RS2 to select the Overlay Registers (RS2 = 1, RS1 = 0, RS0 = 1). After the BLUE write cycle, the three bytes of color information are concatenated into a 24-bit word or an 18-bit word and are written to the overlay register specified by the address register. The address register then increments to the next overlay register which the MPU may modify by simply writing another sequence of red, green, and blue data. A complete set of colors can be loaded into the overlay registers by initially writing the start address and then performing a sequence of RED, GREEN and BLUE writes. The address automatically increments to the next highest location after a BLUE write.

Overlay Color Reads

The MPU writes to the address register (selecting OVERLAY REGISTER read mode, RS2 = 1, RS1 = 1 and RS0 = 1) with the address of the overlay register to be read back. The contents of the overlay register are copied to the RED, GREEN and BLUE registers and the address register increments to point to the next highest overlay register. The MPU then performs three successive read cycles (8 or 6 bits each of red, green, and blue), using RS0 – RS2 to select the Overlay Registers (RS2 = 1, RS1 = 0, RS0 = 1). After the BLUE read cycle, the 24/18 bit contents of the overlay register at the specified address register location is loaded into the RED, GREEN and BLUE registers. The address register then increments to the next overlay register which the MPU can read back by simply reading another sequence of red, green, and blue data. A complete set of colors can be read back from the overlay registers by initially writing the start address and then performing a sequence of RED, GREEN and BLUE reads. The address automatically increments to the next highest location after a BLUE read.

Internal Address Register (ADDR)

When accessing the color palette RAM, the address register resets to 00H following a blue read or write cycle to RAM location FFH. When accessing the overlay color registers, the address register increments following a blue read or write cycle.

However, while accessing the overlay color registers, the four most significant bits (since there are only 15 overlay registers) of the address register (ADDR4–7) are ignored.

To keep track of the red, green, and blue read/write cycles, the address register has two additional bits (ADDRa, ADDRb) that count modulo three, as shown in Table II. They are reset to zero when the MPU writes to the address register, and are not reset to zero when the MPU reads the address register. The MPU does not have access to these bits. The other eight bits of the address register, incremented following a blue read or write cycle, (ADDR0-7) are accessible to the MPU, and are used to address color palette RAM locations and overlay registers, as shown in Table II. ADDR0 is the LSB when the MPU is accessing the RAM or overlay registers. The MPU may read the address register at any time without modifying its contents or the existing read/write mode.

Synchronization

The MPU interface operates asynchronously to the pixel port. Data transfers between the color palette RAM/overlay registers and the color registers (R, G, and B as shown in the block diagram) are synchronized by internal logic, and occur in the period between MPU accesses. The MPU can be accessed at any time, even when the pixel CLOCK is stopped.

8-Bit/6-Bit Color Operation

The Command Register on the ADV473 specifies whether the MPU is reading/writing 8 bits or 6 bits of color information each cycle.

For 8-bit operation, D0 is the LSB and D7 is the MSB.

For 6-bit operation, color data is contained on the lower six bits of the data bus, with D0 being the LSB and D5 the MSB of color data. When writing color data, D6 and D7 are ignored. During color read cycles, D6 and D7 will be a logical “0.” It should be noted that when the ADV473 is in 6-bit mode, full-scale output current will be reduced by approximately 1.5% relative to the 8-bit mode. This is the case since the 2 LSBs of each of the three DACs are always set to zero in 6-bit mode.

ADV473

Command Register (CR)

The ADV473 has an internal command register (CR). This register is 8 bits wide, CR0–CR7 and is directly mapped to the MPU data bus on the part, D0–D7. The command register can be written to or read from. It is not initialized, therefore it must be set. Figure 4 shows what each bit of the CR register controls and shows the values it must be programmed to for various modes of operation.

Color Modes

The ADV473 supports four color modes, 24-bit true-color, 15-bit true-color, 8-bit true-color and 8-bit pseudo-color. The mode of operation is determined by the S0 and S1 inputs, in conjunction with CR7 and CR6 of the command register. S0 and S1 are pipelined to maintain synchronization with the video data. Table III illustrates the modes of operation.

Table III. Color Operation Modes

OL3–OL0	S1, S0	CR7, CR6	Mode	R7–R0	G7–G0	B7–B0
1111	XX	XX	Overlay Color 15	XXH	XXH	XXH
.
0001	XX	XX	Overlay Color 1	XXH	XXH	XXH
0000	00	00	24-Bit True-Color	R7–R0	G7–G0	B7–B0
0000	00	01	24-Bit True-Color	R7–R0	G7–G0	B7–B0
0000	00	10	24-Bit True-Color	R7–R0	G7–G0	B7–B0
0000	00	11	Reserved	Reserved	Reserved	Reserved
0000	01	00	24-Bit True-Color Bypass	R7–R0	G7–G0	B7–B0
0000	01	01	24-Bit True-Color Bypass	R7–R0	G7–G0	B7–B0
0000	01	10	24-Bit True-Color Bypass	R7–R0	G7–G0	B7–B0
0000	01	11	Reserved	Reserved	Reserved	Reserved
0000	10	00	8-Bit Pseudo-Color (Red)	P7–P0	Ignored	Ignored
0000	10	01	8-Bit Pseudo-Color (Green)	Ignored	P7–P0	Ignored
0000	10	10	8-Bit Pseudo-Color (Blue)	Ignored	Ignored	P7–P0
0000	10	11	15-Bit True-Color	Orrrrrgg	gggbbbbb	Ignored
0000	11	00	8-Bit True-Color Bypass (Red)	rrrgggbb	Ignored	Ignored
0000	11	01	8-Bit True-Color Bypass (Green)	Ignored	rrrgggbb	Ignored
0000	11	10	8-Bit True-Color Bypass (Blue)	Ignored	Ignored	rrrgggbb
0000	11	11	15-Bit True-Color Bypass	Orrrrrgg	gggbbbbb	Ignored

X = Don't Care

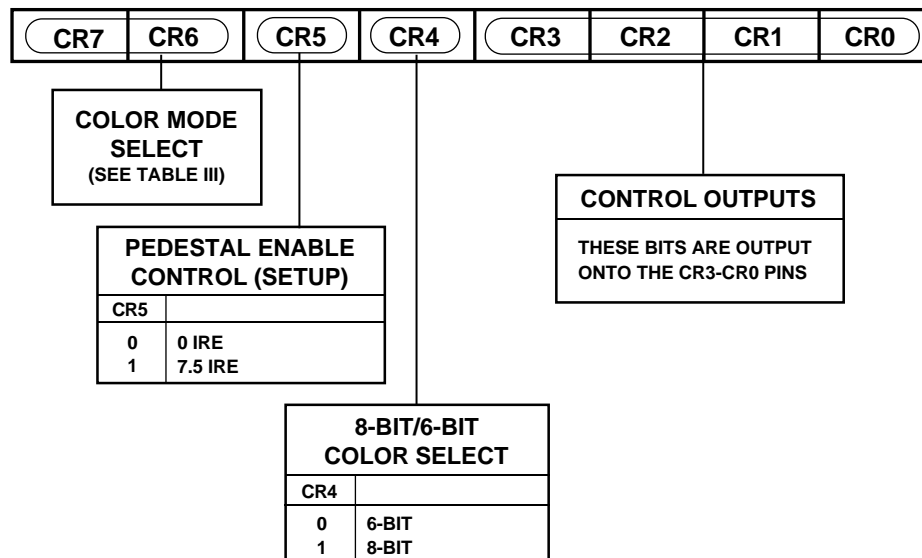

Figure 4. Command Register (CR)

VIDEO MODES**24-Bit True-Color Mode**

Twenty-four bits of RGB color information may be input into the ADV473 every clock cycle. The 24 bits of pixel information are input via the R0–R7, G0–G7, and B0–B7 inputs. R0–R7 address the red color palette RAM, G0–G7 address the green color palette RAM, and B0–B7 address the blue color palette RAM. Each RAM provides 8 bits of color information to the corresponding D/A converter. The pixel read mask register is used in this mode.

24-Bit True-Color Bypass Mode

Twenty-four bits of pixel information may be input into the ADV473 every clock cycle. The 24 bits of pixel information are input via the R0–R7, G0–G7, and B0–B7 inputs. R0–R7 drive the red DAC directly, G0–G7 drive the green DAC directly, and B0–B7 drive the blue DAC directly. The color palette RAMs and pixel read mask register are bypassed.

8-Bit Pseudo-Color Mode

Eight bits of pixel information may be input into the ADV473 every clock cycle. The 8 bits of pixel information (P0–P7) are input via the R0–R7, G0–G7 or B0–B7 inputs, as specified by CR7 and CR6. All three color palette RAMs are addressed by the same 8 bits of pixel data (P0–P7). Each RAM provides 8 bits of color information to the corresponding D/A converter. The pixel read mask register is used in this mode.

8-Bit True-Color Bypass Mode

Eight bits of pixel information may be input into the ADV473 every clock cycle. The 8 bits of pixel information are input via the R0–R7, G0–G7 or B0–B7 inputs, as specified by CR7 and CR6.

Table IV. 8-Bit True-Color Bypass Video Input Format

R0–R7 Inputs Selected	G0–G7 Inputs Selected	B0–B7 Input Selected	Inputs Format
R7	G7	B7	R7
R6	G6	B6	R6
R5	G5	B5	R5
R4	G4	B4	G7
R3	G3	B3	G6
R2	G2	B2	G5
R1	G1	B1	B7
R0	G0	B0	B6

As seen in the table, 3 bits of red, 3 bits of green, and 2 bits of blue data are input. The 3 MSBs of the red and green DACs are driven directly by the inputs, while the 2 MSBs of the blue DAC are driven directly. The 5 LSBs for the red and green DACs, and the 6 LSBs for the blue DAC, are a logical zero. The color palette RAMs and pixel read mask register are bypassed.

15-Bit True-Color Bypass Mode

Fifteen bits of pixel information may be input into the ADV473 every clock cycle. The 15 bits of pixel information (5 bits of red, 5 bits of green, and 5 bits of blue) are input via the R0–R7 and G0–G7 inputs.

Table V. 15-Bit True-Color Video Input Format

Pixel Inputs	Input Format
R7	0
R6	R7
R5	R6
R4	R5
R3	R4
R2	R3
R1	G7
R0	G6
G7	G5
G6	G4
G5	G3
G4	B7
G3	B6
G2	B5
G1	B4
G0	B3

The 5 MSBs of the red, green, and blue DACs are driven directly by the inputs. The 3 LSBs are a logical zero. The color palette RAMs and pixel read mask register are bypassed.

15-Bit True-Color Mode

Fifteen bits of pixel information may be input into the ADV473 every clock cycle. The 15 bits of pixel information are input to the device via R0–R7 and G0–G7 according to Table V. This input data points to the top 32 locations of the color palette RAM, i.e., locations 223 to 255. The 15-bit pixel input data indexes a 24-bit red, green and blue value which is clocked to the three DACs.

Overlays

The overlay inputs, OL0–OL3, have priority regardless of the color mode as shown in Table III.

Pixel Read Mask Register

The 8-bit pixel read mask register is implemented as three 8-bit pixel read mask registers, one each for the R0–R7, G0–G7, and B0–B7 inputs. When writing to the pixel read mask register, the same data is written to all three registers. The read mask registers are located just before the color palette RAMs. Thus, they are used only in the 24-bit true-color and 8-bit pseudo-color modes since these are the only modes that use the color palette RAMs.

The contents of the pixel read mask register, which may be accessed by the MPU at any time, are bit-wise logically ANDed with the 8-bit inputs prior to addressing the color palette RAMs. Bit D0 of the pixel read mask register corresponds to pixel input P0 (R0, G0, or B0 depending on the mode). Bit D0 also corresponds to data bus Bit D0.

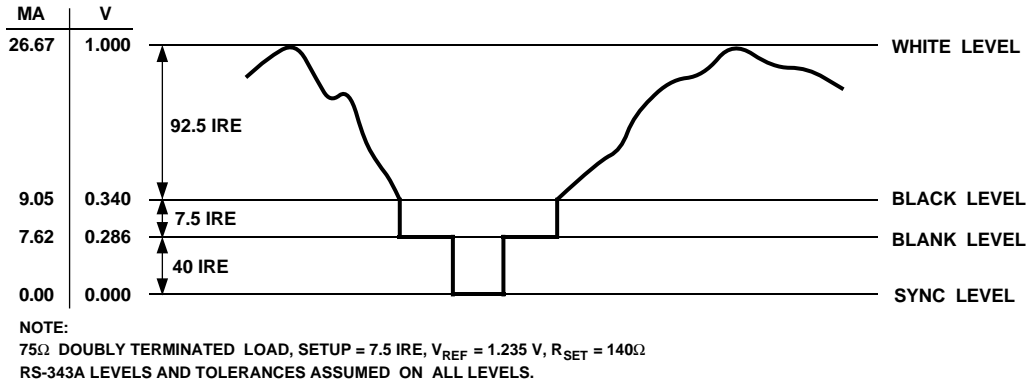

Figure 5. Composite Video Output Waveform (Setup = 7.5 IRE)

Table VI. Video Output Truth Table (Setup = 7.5 IRE)

Description	I_{OUT} (mA)	$\overline{\text{SYNC}}$	$\overline{\text{BLANK}}$	DAC Input Data
WHITE	26.67	1	1	FFH
DATA	Data+9.05	1	1	Data
DATA-SYNC	Data+1.44	0	1	Data
BLACK	9.05	1	1	00H
BLACK-SYNC	1.44	0	1	00H
BLANK	7.62	1	0	XXH
SYNC	0	0	0	XXH

NOTE
Typical with full-scale IOR, IOG, IOB = 26.67 mA, SETUP = 7.5 IRE, $V_{REF} = 1.235\text{ V}$, $R_{SET} = 140\Omega$. External voltage reference adjusted for 26.67 mA full-scale output.

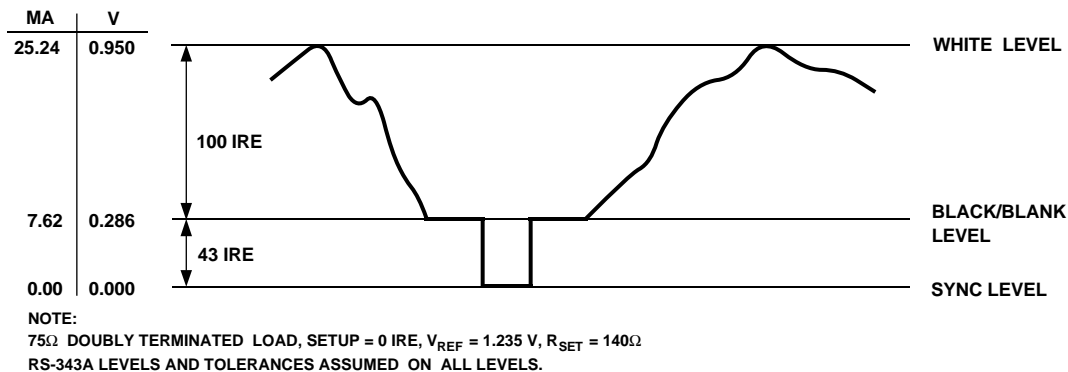

Figure 6. Composite Video Output Waveform (Setup = 0 IRE)

Table VII. Video Output Truth Table (SETUP = 0 IRE)

Description	I_{OUT} (mA)	$\overline{\text{SYNC}}$	$\overline{\text{BLANK}}$	DAC Input Data
WHITE	25.24	1	1	FFH
DATA	Data+7.62	1	1	Data
DATA-SYNC	Data	0	1	Data
BLACK	7.62	1	1	00H
BLACK-SYNC	0	0	1	00H
BLANK	7.62	1	0	XXH
SYNC	0	0	0	XXH

NOTE
Typical with full-scale IOR, IOG, IOB = 25.24 mA, SETUP = 0 IRE, $V_{REF} = 1.235\text{ V}$, $R_{SET} = 140\Omega$. External voltage reference adjusted for 26.67 mA full-scale output.

PC BOARD LAYOUT CONSIDERATIONS

The layout should be optimized for lowest noise on the ADV473 power and ground lines by shielding the digital inputs and providing good decoupling. The lead length between groups of V_{AA} and GND pins should be minimized so as to minimize inductive ringing.

Ground Planes

The ground plane should encompass all ADV473 ground pins, current/voltage reference circuitry, power supply bypass circuitry for the ADV473, the analog output traces, and all the digital signal traces leading up to the ADV473.

Power Planes

The ADV473 and any associated analog circuitry should have its own power plane, referred to as the analog power plane. This power plane should be connected to the regular PCB power plane (V_{CC}) at a single point through a ferrite bead, as illustrated in Figures 7 and 8. This bead should be located within three inches of the ADV473.

The PCB power plane should provide power to all digital logic on the PC board, and the analog power plane should provide power to all ADV473 power pins and voltage reference circuitry.

Plane-to-plane noise coupling can be reduced by ensuring that portions of the regular PCB power and ground planes do not overlay portions of the analog power plane, unless they can be arranged such that the plane-to-plane noise is common mode.

Supply Decoupling

For optimum performance, bypass capacitors should be installed using the shortest leads possible, consistent with reliable operation, to reduce the lead inductance. Best performance is obtained with a 0.1 μF ceramic capacitor decoupling each of the two groups of V_{AA} pins to GND. These capacitors should be placed as close as possible to the device.

It is important to note that while the ADV473 contains circuitry to reject power supply noise, this rejection decreases with frequency. If a high frequency switching power supply is used, the designer should pay close attention to reducing power supply noise and should consider using a three-terminal voltage regulator for supplying power to the analog power plane.

Digital Signal Interconnect

The digital inputs to the ADV473 should be isolated as much as possible from the analog outputs and other analog circuitry. Also, these input signals should not overlay the analog power plane.

Due to the high clock rates involved, long clock lines to the ADV473 should be avoided to reduce noise pickup.

Any active termination resistors for the digital inputs should be connected to the regular PCB power plane (V_{CC}), and not to the analog power plane.

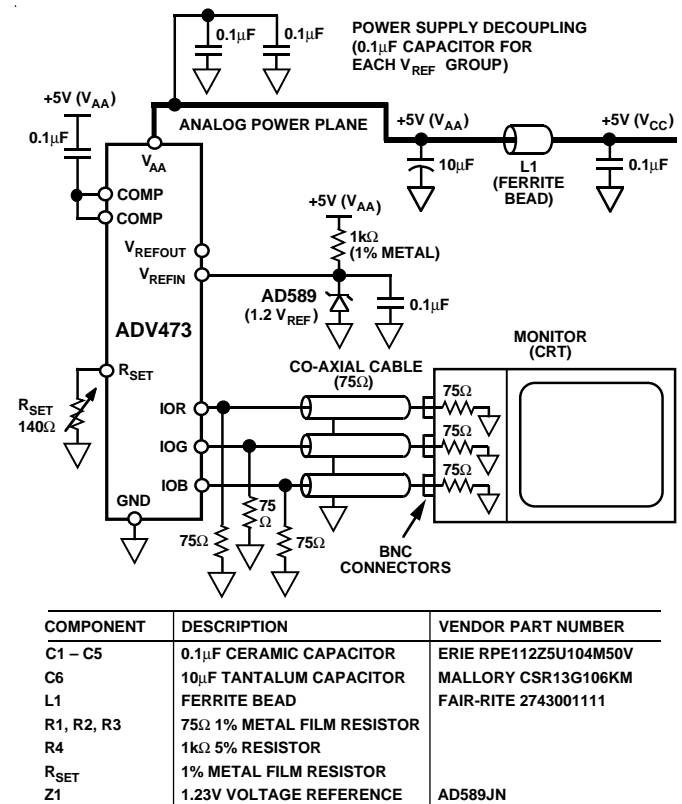

Figure 7. Typical Connection Diagram (External Voltage Reference)

ADV473

Analog Signal Interconnect

The ADV473 should be located as close as possible to the output connectors to minimize noise pickup and reflections due to impedance mismatch.

The video output signals should overlay the ground plane, and not the analog power plane, to maximize the high frequency power supply rejection.

For maximum performance, the analog outputs should each have a 75 Ω load resistor connected to GND. The connection between the current output and GND should be as close as possible to the ADV473 to minimize reflections.

For more information on circuit board design and layout, see application note entitled "Design and Layout of a Video Graphics System for Reduced EMI" available from Analog Devices, Publication No. E1309-15-10/89.

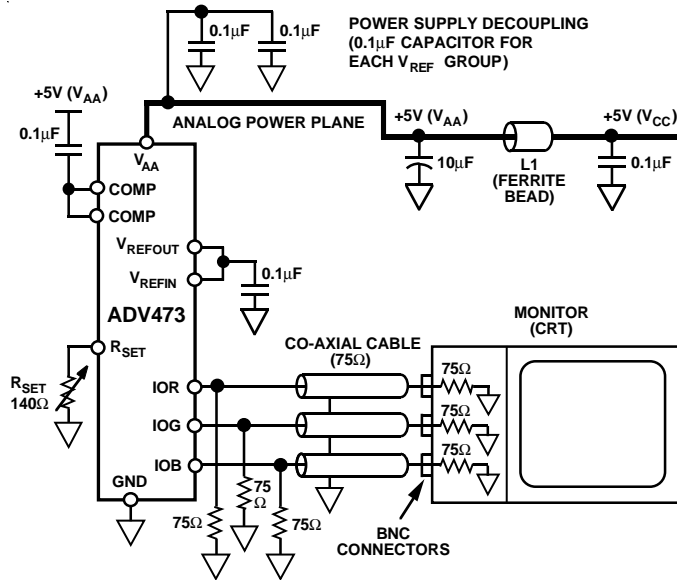

COMPONENT	DESCRIPTION	VENDOR PART NUMBER
C1 - C5	0.1µF CERAMIC CAPACITOR	ERIE RPE112Z5U104M50V
C6	10µF TANTALUM CAPACITOR	MALLORY CSR13G106KM
L1	FERRITE BEAD	FAIR-RITE 2743001111
R1, R2, R3	75Ω 1% METAL FILM RESISTOR	
R _{SET}	1% METAL FILM RESISTOR	

Figure 8. Typical Connection Diagram (Internal Voltage Reference)

Package Thermal Considerations

In certain circumstances, the 135 MHz version of the ADV473 may require forced air cooling or the addition of a heatsink. The 68-pin PLCC has a heat resistance characteristic as shown in Table VIII.

It should be noted that information on Package Thermal Characteristics published herein may not be the most up to date at the time of reading this. Advances in packaging technology will inevitably lead to improvements in thermal data. Please contact your local sales office for the most up-to-date information.

Table VIII. Thermal Resistance vs. Airflow

Air Velocity (Linear Feet/Min)	0 (Still Air)	50	100	200
θ_{JA} (°C/W)	32	26	19	16

OUTLINE DIMENSIONS

Dimensions shown in inches and (mm).

Plastic Leaded Chip Carrier (P-68A)

