



5V 256K X 16 CMOS DRAM (Fast Page Mode)

Features

- Organization: 262,144 words × 16 bits
- High speed
 - 25/30/35/50 ns $\overline{\text{RAS}}$ access time
 - 12/16/18/25 ns column address access time
 - 7/10/10/10 ns $\overline{\text{CAS}}$ access time
- Low power consumption
 - Active: 770 mW max (ASAS4C256K16FO-50)
 - Standby: 5.5 mW max, CMOS I/O
- Fast page mode
- AS4C256K16FO-50 timings are also valid for AS4C256K16FO-60.
- Refresh
 - 512 refresh cycles, 8 ms refresh interval
 - $\overline{\text{RAS}}$ -only or $\overline{\text{CAS}}$ -before- $\overline{\text{RAS}}$ refresh or self-refresh
 - Self-refresh option is available for new generation device only. Contact Alliance for more information.
- Read-modify-write
- TTL-compatible, three-state I/O
- JEDEC standard packages
 - 400 mil, 40-pin SOJ
 - 400 mil, 40/44-pin TSOP II
- Single 5V power supply/built-in V_{bb} generator
- Latch-up current > 200 mA

Pin arrangement

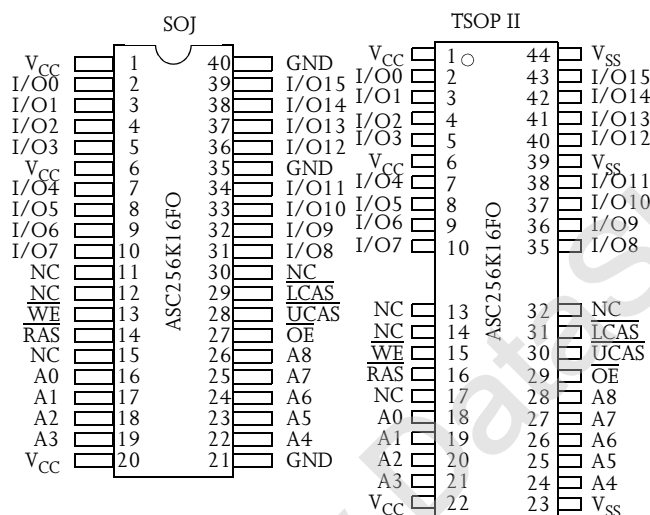

Pin designation

Pin(s)	Description
A0 to A8	Address inputs
$\overline{\text{RAS}}$	Row address strobe
I/O0 to I/O15	Input/output
$\overline{\text{OE}}$	Output enable
$\overline{\text{UCAS}}$	Column address strobe, upper byte
$\overline{\text{LCAS}}$	Column address strobe, lower byte
$\overline{\text{WE}}$	Read/write control
VCC	Power (+5V ± 10%)
GND	Ground

Selection guide

	Symbol	-25	-30	-35	-50	Unit
Maximum $\overline{\text{RAS}}$ access time	t_{RAC}	25	30	35	50	ns
Maximum column address access time	t_{CAA}	12	16	18	25	ns
Maximum $\overline{\text{CAS}}$ access time	t_{CAC}	7	10	10	10	ns
Maximum output enable ($\overline{\text{OE}}$) access time	t_{OEA}	7	10	10	10	ns
Minimum read or write cycle time	t_{RC}	40	65	70	85	ns
Minimum EDO page mode cycle time	t_{PC}	12	12	14	25	ns
Maximum operating current	I_{CC1}	200	180	160	140	mA
Maximum CMOS standby current	I_{CC2}	2.0	2.0	2.0	2.0	mA



Functional description

The AS4C256K16FO is a high-performance 4 megabit CMOS Dynamic Random Access Memory (DRAM) device organized as 262,144 words \times 16 bits. The AS4C256K16FO is fabricated with advanced CMOS technology and designed with innovative design techniques resulting in high speed, extremely low power and wide operating margins at component and system levels.

The AS4C256K16FO features a high-speed page mode operation in which high speed read, write and read-write are performed on any of the 512 \times 16 bits defined by the column address. The asynchronous column address uses an extremely short row address capture time to ease the system-level timing constraints associated with multiplexed addressing. Output is tri-stated by a column address strobe ($\overline{\text{CAS}}$) which acts as an output enable independent of $\overline{\text{RAS}}$. Very fast $\overline{\text{CAS}}$ to output access time eases system design.

Refresh on the 512 address combinations of A0–A8 during an 8 ms period is accomplished by performing any of the following:

- $\overline{\text{RAS}}$ -only refresh cycles
- Hidden refresh cycles
- $\overline{\text{CAS}}$ -before- $\overline{\text{RAS}}$ refresh cycles
- Normal read or write cycles
- Self-refresh cycles.*

The AS4C256K16FO is available in standard 40-pin plastic SOJ and 44-pin TSOP II packages compatible with widely available automated testing and insertion equipment. System level features include single power supply of $5\text{V} \pm 10\%$ tolerance and direct interface with TTL logic families.

Logic block diagram

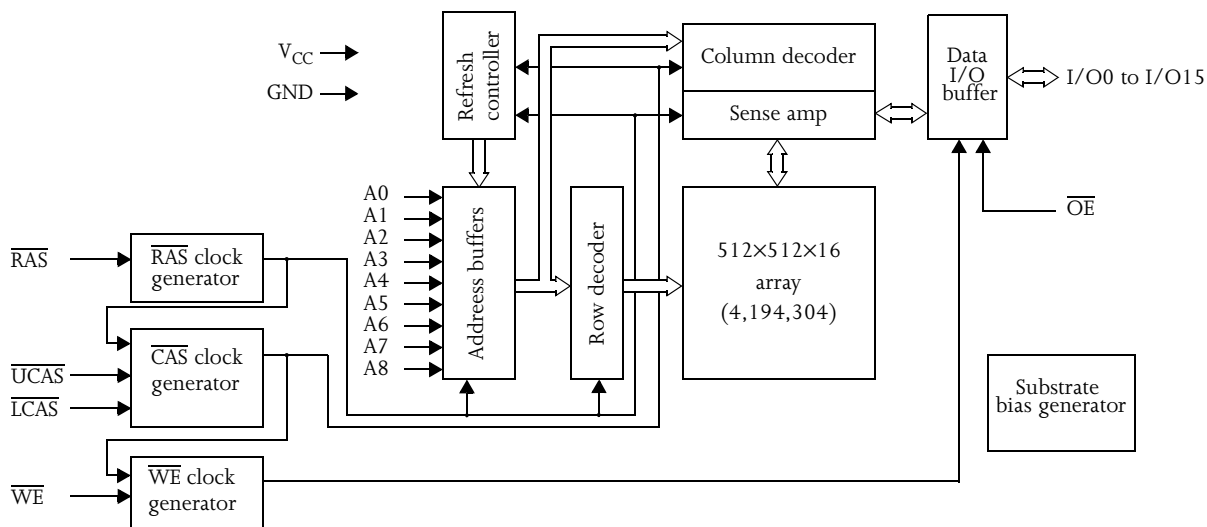

Recommended operating conditions

Parameter	Symbol	Min	Typ	Max	Unit
Supply voltage	V_{CC}	4.5	5.0	5.5	V
	GND	0.0	0.0	0.0	V
Input voltage	V_{IH}	2.4	–	$V_{CC} + 1$	V
	V_{IL}	–1.0	–	0.8	V

* Self-refresh option is available for new generation device only. Contact Alliance for more information.



Absolute maximum ratings

Parameter	Symbol	Min	Max	Unit
Input voltage	V_{IN}	-1.0	+7.0	V
Output voltage	V_{OUT}	-1.0	+7.0	V
Power supply voltage	V_{CC}	-1.0	+7.0	V
Operating temperature	T_{OPR}	0	+70	°C
Storage temperature (plastic)	T_{STG}	-55	+150	°C
Soldering temperature × time	T_{SOLDER}	–	260 × 10	°C × sec
Power dissipation	P_D	–	1	W
Short circuit output current	I_{OUT}	–	50	mA
Latch-up current		200	–	mA

Note: Stresses greater than those listed under Absolute Maximum Ratings may cause permanent damage to the device. This is a stress rating only and functional operation of the device at these or any other conditions outside those indicated in the operational sections of this specification is not implied. Exposure to absolute maximum rating conditions for extended periods may affect reliability.

DC electrical characteristics

($V_{CC} = 5 \pm 10\%$, $GND = 0V$, $T_a = 0^\circ C$ to $+70^\circ C$)

Parameter	Symbol	Test conditions	-25		-30		-35		-50		Unit	Note
			Min	Max	Min	Max	Min	Max	Min	Max		
Input leakage current	I_{IL}	$0V \leq V_{IN} \leq +5.5V$ pins not under test = 0V	-10	10	-10	10	-10	10	-10	10	µA	
Output leakage current	I_{OL}	D_{OUT} disabled, $0V \leq V_{OUT} \leq +5.5V$	-10	10	-10	10	-10	10	-10	10	µA	
Operating power supply current	I_{CC1}	\overline{RAS} , \overline{UCAS} , \overline{LCAS} , address cycling; $t_{RC} = \min$	–	200	–	180	–	160	–	140	mA	1,2
TTL standby power supply current	I_{CC2}	$\overline{RAS} = \overline{UCAS} = \overline{LCAS} = V_{IH}$	–	2.0	–	2.0	–	2.0	–	2.0	mA	
Average power supply current, \overline{RAS} refresh mode	I_{CC3}	\overline{RAS} cycling, $\overline{UCAS} = \overline{LCAS} = V_{IH}$, $t_{RC} = \min$	–	120	–	200	–	190	–	140	mA	1
Fast page mode average power supply current	I_{CC4}	$\overline{RAS} = \overline{UCAS} = \overline{LCAS} = V_{IL}$, address cycling; $t_{SC} = \min$	–	130	–	190	–	180	–	70	mA	1,2
CMOS standby power supply current	I_{CC5}	$\overline{RAS} = \overline{UCAS} = \overline{LCAS} = V_{CC} - 0.2V$	–	0.60	–	1.0	–	1.0	–	1.0	mA	
CAS-before-RAS refresh power supply current	I_{CC6}	\overline{RAS} , \overline{UCAS} , \overline{LCAS} , cycling; $t_{RC} = \min$	–	120	–	200	–	190	–	140	mA	1
Output voltage	V_{OH}	$I_{OUT} = -5.0 mA$	2.4	–	2.4	–	2.4	–	2.4	–	V	
	V_{OL}	$I_{OUT} = 4.2 mA$	–	0.4	–	0.4	–	0.4	–	0.4	V	
Self refresh current	I_{CC7}	$\overline{RAS} = \overline{UCAS} = \overline{LCAS} = V_{IL}$, $\overline{WE} = \overline{OE} = A0 - A8 = V_{CC} - 0.2V$, $DQ0 - DQ15 = V_{CC} - 0.2V$, 0.2V are open	–	2.0	–	2.0	–	2.0	–	2.0	mA	



AC parameters common to all waveforms

 $(V_{CC} = 5V \pm 10\%, GND = 0V, T_a = 0^\circ C \text{ to } +70^\circ C)$

Standard Symbol	Parameter	-25		-30		-35		-50		Unit	Notes
		Min	Max	Min	Max	Min	Max	Min	Max		
t_{RC}	Random read or write cycle time	45	–	65	–	70	–	85	–	ns	
t_{RP}	\overline{RAS} precharge time	15	–	25	–	25	–	25	–	ns	
t_{RAS}	\overline{RAS} pulse width	25	75K	30	75K	35	75K	50	75K	ns	
t_{CAS}	\overline{CAS} pulse width	4	–	5	–	6	–	10	–	ns	
t_{RCD}	\overline{RAS} to \overline{CAS} delay time	10	17	15	20	16	24	15	35	ns	6
t_{RAD}	\overline{RAS} to column address delay time	8	13	10	14	11	17	15	25	ns	7
$t_{RSH(R)}$	\overline{CAS} to \overline{RAS} hold time (read cycle)	7	–	10	–	10	–	10	–	ns	
t_{CSH}	\overline{RAS} to \overline{CAS} hold time	20	–	30	–	35	–	50	–	ns	
t_{CRP}	\overline{CAS} to \overline{RAS} precharge time	5	–	5	–	5	–	5	–	ns	
t_{ASR}	Row address setup time	0	–	0	–	0	–	0	–	ns	
t_{RAH}	Row address hold time	5	–	5	–	6	–	9	–	ns	
t_T	Transition time (rise and fall)	1.5	50	1.5	50	1.5	50	3	50	ns	4,5
t_{REF}	Refresh period	–	8	–	8	–	8	–	8	ms	3
t_{CLZ}	\overline{CAS} to output in low Z	0	–	0	–	0	–	3	–	ns	8

Read cycle

 $(V_{CC} = 5V \pm 10\%, GND = 0V, T_a = 0^\circ C \text{ to } +70^\circ C)$

Standard Symbol	Parameter	-25		-30		-35		-50		Unit	Notes
		Min	Max	Min	Max	Min	Max	Min	Max		
t_{RAC}	Access time from \overline{RAS}	–	25	–	30	–	35	–	50	ns	6
t_{CAC}	Access time from \overline{CAS}	–	7	–	10	–	10	–	10	ns	6,13
t_{AA}	Access time from address	–	12	–	16	–	18	–	25	ns	7,13
$t_{AR(R)}$	Column add hold from \overline{RAS}	19	–	26	–	28	–	30	–	ns	
t_{RCS}	Read command setup time	0	–	0	–	0	–	0	–	ns	
t_{RCH}	Read command hold time to \overline{CAS}	0	–	0	–	0	–	0	–	ns	9
t_{RRH}	Read command hold time to \overline{RAS}	0	–	0	–	0	–	0	–	ns	9
t_{RAL}	Column address to \overline{RAS} Lead time	12	–	16	–	18	–	25	–	ns	
t_{CPN}	\overline{CAS} precharge time	4	–	3	–	4	–	5	–	ns	
t_{OFF}	Output buffer turn-off time	0	6	0	8	0	8	0	8	ns	8,10



Write cycle

 $(V_{CC} = 5V \pm 10\%, GND = 0V, T_a = 0^\circ C \text{ to } +70^\circ C)$

Standard Symbol	Parameter	-25		-30		-35		-50		Unit	Notes
		Min	Max	Min	Max	Min	Max	Min	Max		
t_{ASC}	Column address setup time	0	–	0	–	0	–	0	–	ns	
t_{CAH}	Column address hold time	5	–	5	–	5	–	9	–	ns	
t_{AWR}	Column address hold time to \overline{RAS}	19	–	26	–	28	–	30	–	ns	
t_{WCS}	Write command setup time	0	–	0	–	0	–	0	–	ns	11
t_{WCH}	Write command hold time	5	–	5	–	5	–	9	–	ns	11
t_{WCR}	Write command hold time to \overline{RAS}	19	–	26	–	28	–	30	–	ns	
t_{WCP}	Write command pulse width	5	–	5	–	5	–	9	–	ns	
t_{RWL}	Write command to \overline{RAS} lead time	7	–	10	–	11	–	12	–	ns	
t_{CWL}	Write command to \overline{CAS} lead time	5	–	10	–	11	–	12	–	ns	
t_{DS}	Data-in setup time	0	–	0	–	0	–	0	–	ns	12
t_{DH}	Data-in hold time	5	–	5	–	5	–	9	–	ns	12
t_{DHR}	Data-in hold time to \overline{RAS}	19	–	26	–	28	–	30	–	ns	

Read-modify-write cycle

 $(V_{CC} = 5V \pm 10\%, GND = 0V, T_a = 0^\circ C \text{ to } +70^\circ C)$

Standard Symbol	Parameter	-25		-30		-35		-50		Unit	Notes
		Min	Max	Min	Max	Min	Max	Min	Max		
t_{RWC}	Read-write cycle time	100	–	100	–	105	–	120	–	ns	
t_{RWD}	\overline{RAS} to \overline{WE} delay time	34	–	50	–	54	–	60	–	ns	11
t_{CWD}	\overline{CAS} to \overline{WE} delay time	17	–	26	–	28	–	30	–	ns	11
t_{AWD}	Column address to \overline{WE} delay time	21	–	32	–	35	–	40	–	ns	11
$t_{RSH(W)}$	\overline{CAS} to \overline{RAS} hold time (write)	7	–	10	–	10	–	12	–	ns	
$t_{CAS(W)}$	\overline{CAS} pulse width (write)	15	–	15	–	15	–	15	–	ns	

Fast page mode cycle

 $(V_{CC} = 5V \pm 10\%, GND = 0V, T_a = 0^\circ C \text{ to } +70^\circ C)$

Standard Symbol	Parameter	-25		-30		-35		-50		Unit	Notes
		Min	Max	Min	Max	Min	Max	Min	Max		
t_{PC}	Read or write cycle time	8	–	12	–	14	–	25	–	ns	14
t_{CAP}	Access time from \overline{CAS} precharge	–	14	–	19	–	21	–	23	ns	13
t_{CP}	\overline{CAS} precharge time	3	–	3	–	4	–	5	–	ns	
t_{PCM}	Fast page mode RMW cycle	56	–	56	–	58	–	60	–	ns	
t_{CRW}	Page mode \overline{CAS} pulse width (RMW)	44	–	44	–	46	–	50	–	ns	
t_{RASP}	\overline{RAS} pulse width	25	75K	30	75K	35	75K	50	75K	ns	



Refresh cycle

 $(V_{CC} = 5V \pm 10\%, GND = 0V, T_a = 0^\circ C \text{ to } +70^\circ C)$

Standard Symbol	Parameter	-25		-30		-35		-50		Unit	Notes
		Min	Max	Min	Max	Min	Max	Min	Max		
t_{CSR}	\overline{CAS} setup time (\overline{CAS} -before- \overline{RAS})	10	–	10	–	10	–	10	–	ns	3
t_{CHR}	\overline{CAS} hold time (\overline{CAS} -before- \overline{RAS})	7	–	7	–	8	–	10	–	ns	3
t_{RPC}	\overline{RAS} precharge to \overline{CAS} hold time	0	–	0	–	0	–	0	–	ns	
t_{CPT}	\overline{CAS} precharge time (\overline{CAS} -before- \overline{RAS} counter test)	8	–	8	–	8	–	8	–	ns	

Output enable

 $(V_{CC} = 5V \pm 10\%, GND = 0V, T_a = 0^\circ C \text{ to } +70^\circ C)$

Standard Symbol	Parameter	-25		-30		-35		-50		Unit	Notes
		Min	Max	Min	Max	Min	Max	Min	Max		
t_{ROH}	\overline{RAS} hold time referenced to \overline{OE}	5	–	5	–	5	–	5	–	ns	
t_{OEA}	\overline{OE} access time	–	8	–	10	–	10	–	10	ns	
t_{OED}	\overline{OE} to data delay	5	–	5	–	5	–	8	–	ns	
t_{OEZ}	Output buffer turnoff delay from \overline{OE}	–	6	–	8	–	8	–	8	ns	8
t_{OEH}	\overline{OE} command hold time	5	–	8	–	8	–	8	–	ns	

Self refresh cycle

 $(V_{CC} = 5V \pm 10\%, GND = 0V, T_a = 0^\circ C \text{ to } +70^\circ C)$

Standard Symbol	Parameter	-25		-30		-35		-50		Unit	Notes
		Min	Max	Min	Max	Min	Max	Min	Max		
t_{RASS}	\overline{RAS} pulse width (CBR self refresh)	100K	–	100K	–	100K	–	100K	–	ns	
t_{RPS}	\overline{RAS} precharge time (CBR self refresh)	85	–	85	–	85	–	85	–	ns	
t_{CHS}	\overline{CAS} hold time (CBR self refresh)	30	–	30	–	30	–	30	–	ns	

Notes

- I_{CC1} , I_{CC3} , I_{CC4} , and I_{CC6} depend on cycle rate.
- I_{CC1} and I_{CC4} depend on output loading. Specified values are obtained with the output open.
- An initial pause of 200 μ s is required after power-up followed by any 8 \overline{RAS} cycles before proper device operation is achieved. In the case of an internal refresh counter, a minimum of 8 \overline{CAS} -before- \overline{RAS} initialization cycles instead of 8 \overline{RAS} cycles are required. 8 initialization cycles are required after extended periods of bias without clocks (greater than 8 ms).
- AC characteristics assume $t_T = 5$ ns. All AC parameters are measured with a load equivalent to two TTL loads and 100 pF, $V_{IL}(\text{min}) \geq GND$ and $V_{IH}(\text{max}) \leq V_{CC}$.
- $V_{IH}(\text{min})$ and $V_{IL}(\text{max})$ are reference levels for measuring timing of input signals. Transition times are measured between V_{IH} and V_{IL} .
- Operation within the $t_{RCD}(\text{max})$ limit insures that $t_{RAC}(\text{max})$ can be met. $t_{RCD}(\text{max})$ is specified as a reference point only. If t_{RCD} is greater than the specified $t_{RCD}(\text{max})$ limit, then access time is controlled exclusively by t_{CAC} .
- Operation within the $t_{RAD}(\text{max})$ limit insures that $t_{RAC}(\text{max})$ can be met. $t_{RAD}(\text{max})$ is specified as a reference point only. If t_{RAD} is greater than the specified $t_{RAD}(\text{max})$ limit, then access time is controlled exclusively by t_{AA} .
- Assumes three state test load (5 pF and a 380 Ω Thevenin equivalent).
- Either t_{RCH} or t_{RRH} must be satisfied for a read cycle.
- $t_{OFF}(\text{max})$ defines the time at which the output achieves the open circuit condition; it is not referenced to output voltage levels.
- t_{WS} , t_{WCH} , t_{RWD} , t_{CWD} and t_{AWD} are not restrictive operating parameters. They are included in the datasheet as electrical characteristics only. If $t_{WS} \geq t_{WS}(\text{min})$ and $t_{WH} \geq t_{WH}(\text{min})$, the cycle is an early write cycle and data out pins will remain open circuit, high impedance, throughout the cycle. If $t_{RWD} \geq t_{RWD}(\text{min})$, $t_{CWD} \geq t_{CWD}(\text{min})$ and $t_{AWD} \geq t_{AWD}(\text{min})$, the cycle is a read-write cycle and the data out will contain data read from the selected cell. If neither of the above conditions is satisfied, the condition of the data out at access time is indeterminate.
- These parameters are referenced to \overline{CAS} leading edge in early write cycles and to \overline{WE} leading edge in read-write cycles.
- Access time is determined by the longest of t_{CAA} or t_{CAC} or t_{CAP}
- $t_{ASC} \geq t_{CP}$ to achieve $t_{PC}(\text{min})$ and $t_{CAP}(\text{max})$ values.
- These parameters are sampled, but not 100% tested.



Key to switching waveforms



Read cycle waveform

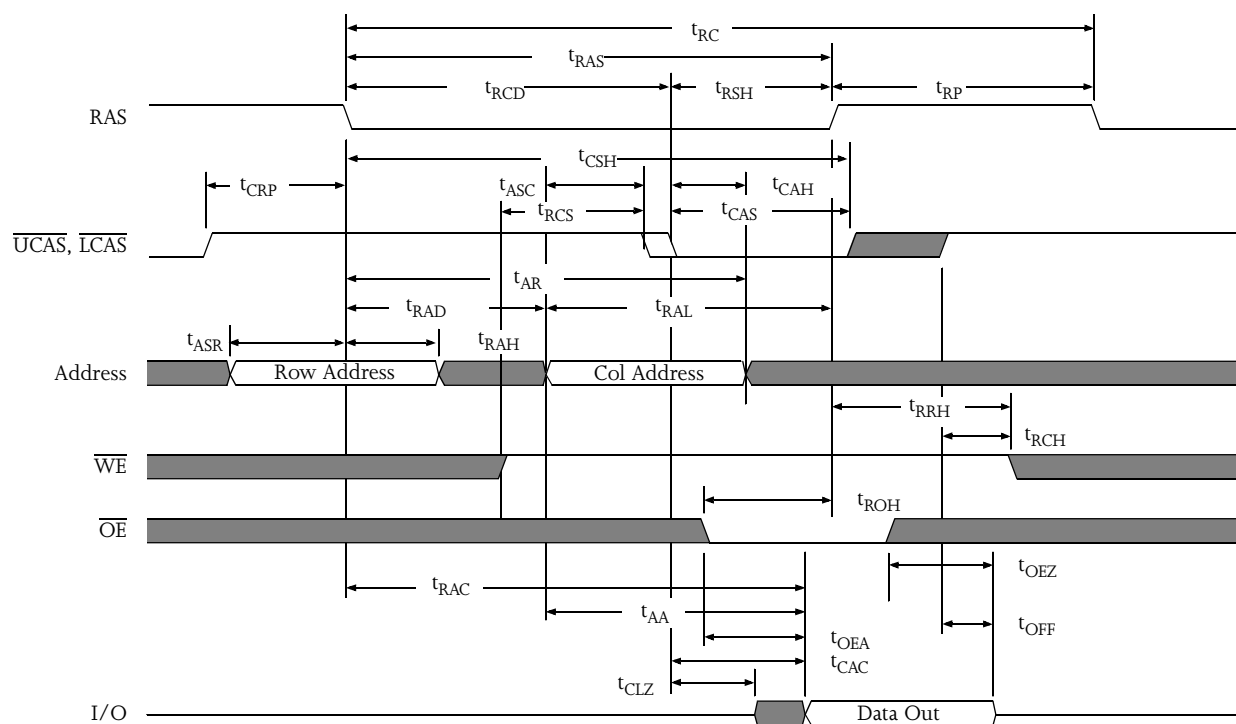



Upper byte read waveform

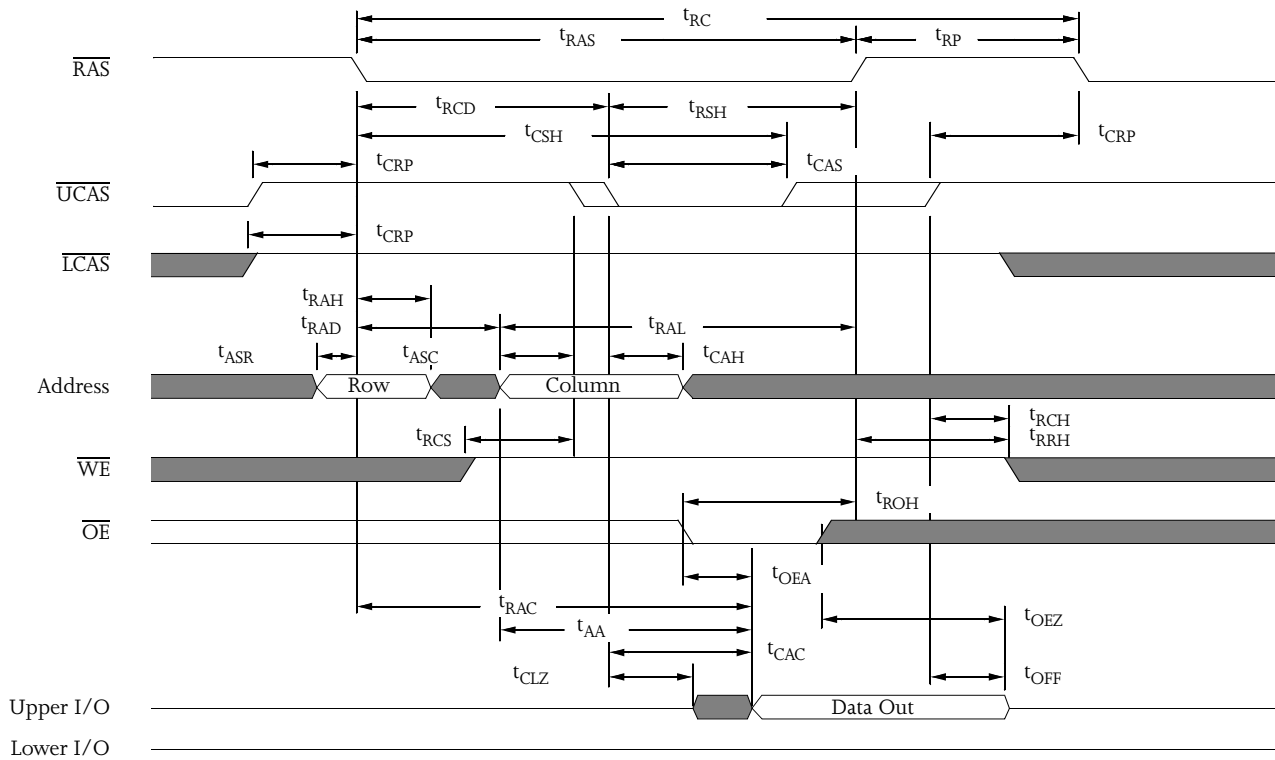

Lower byte read waveform

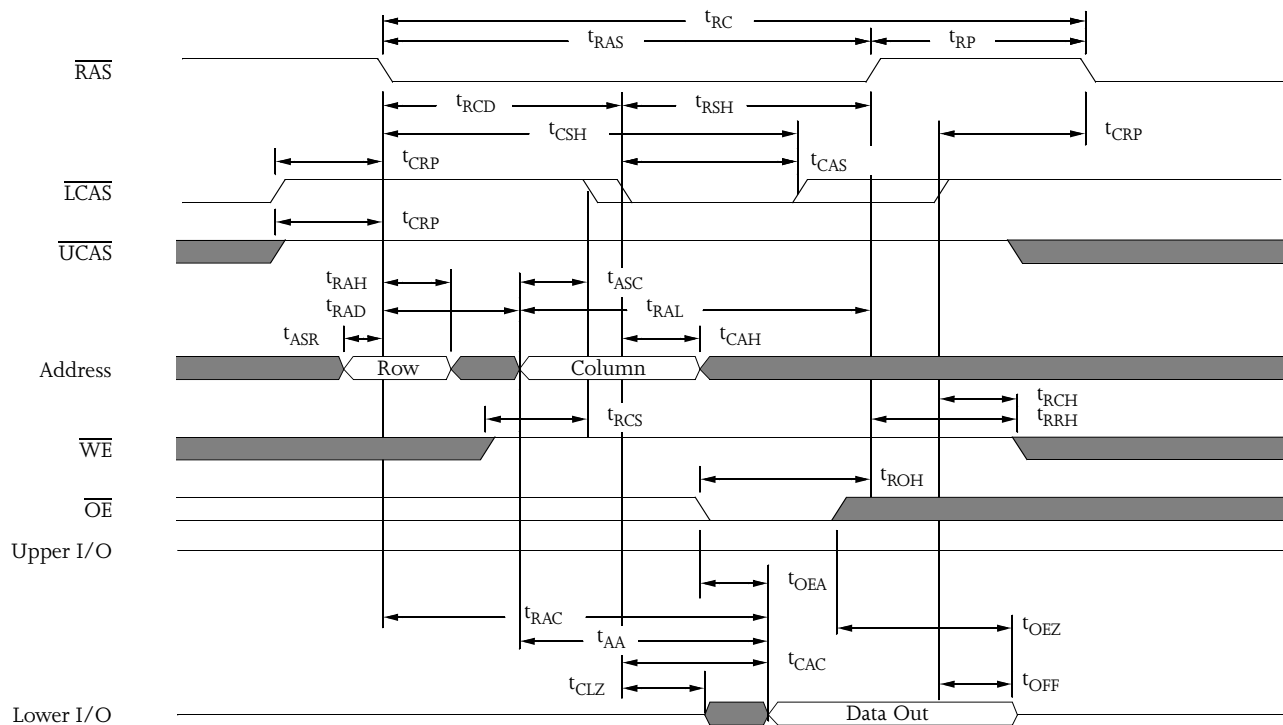



Early write waveform

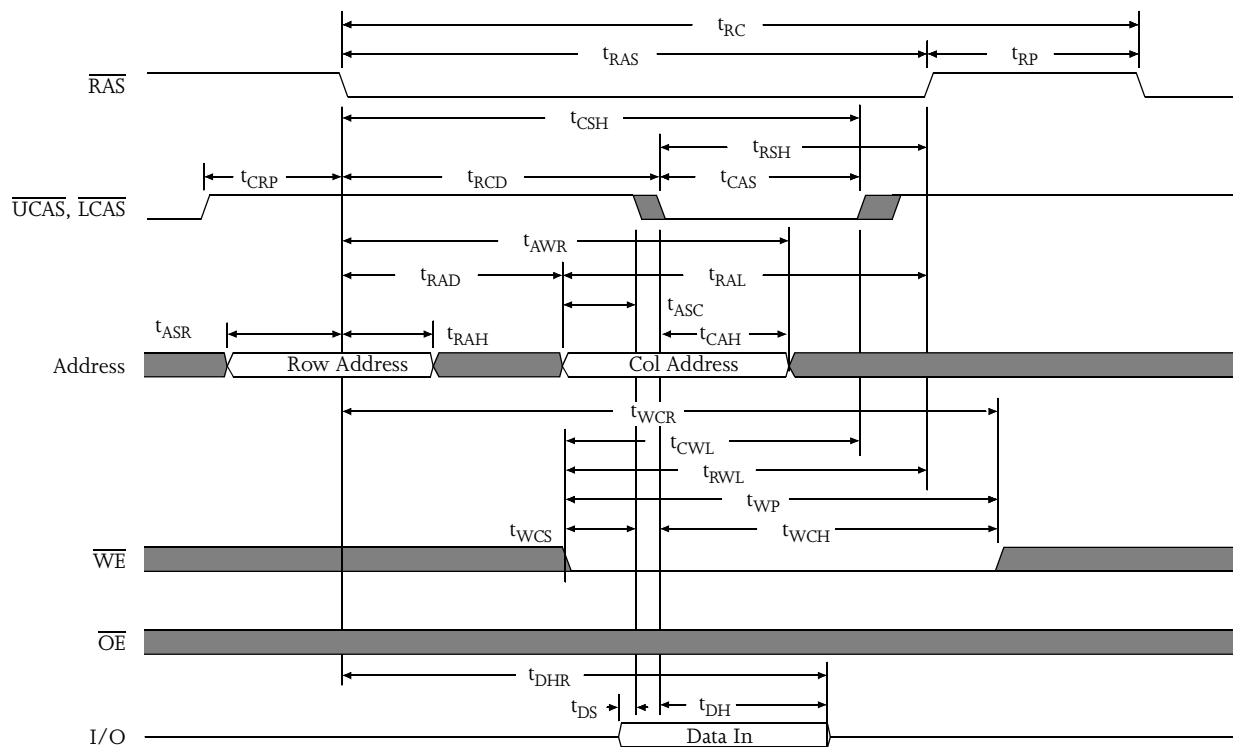



Upper byte early write waveform

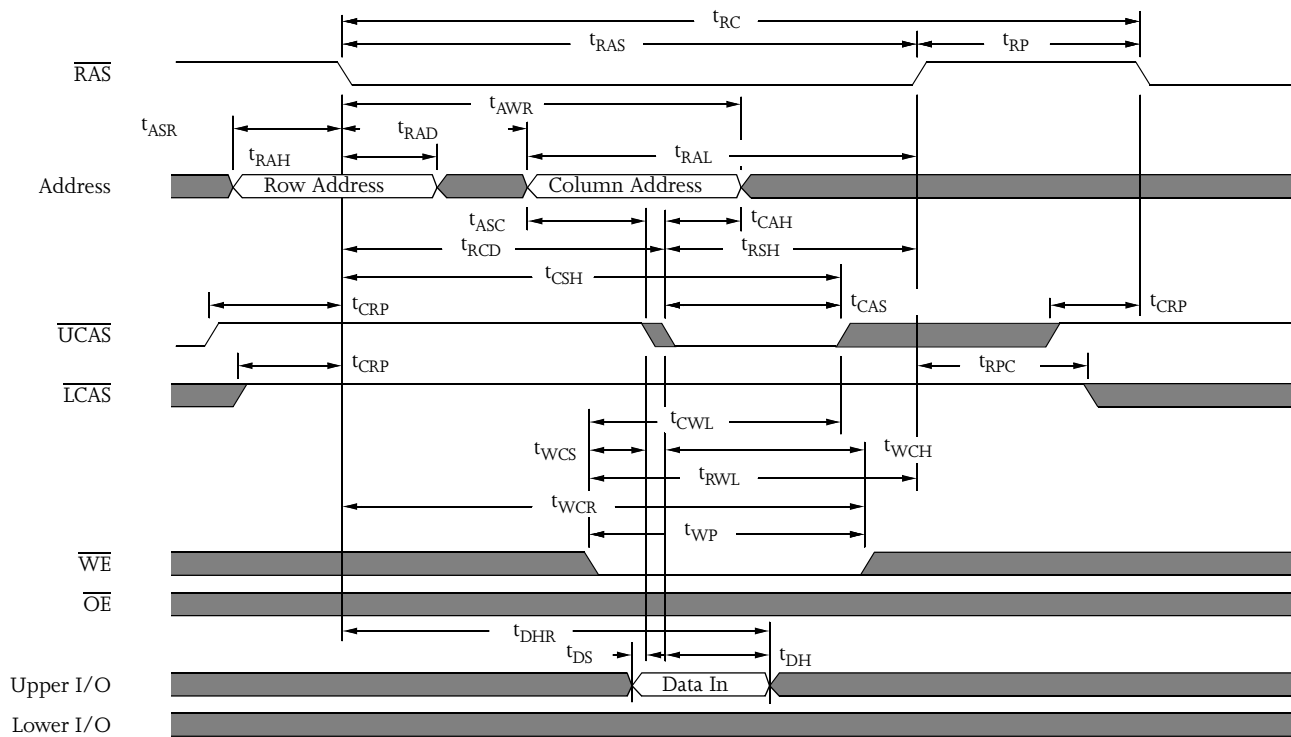



Lower byte early write waveform

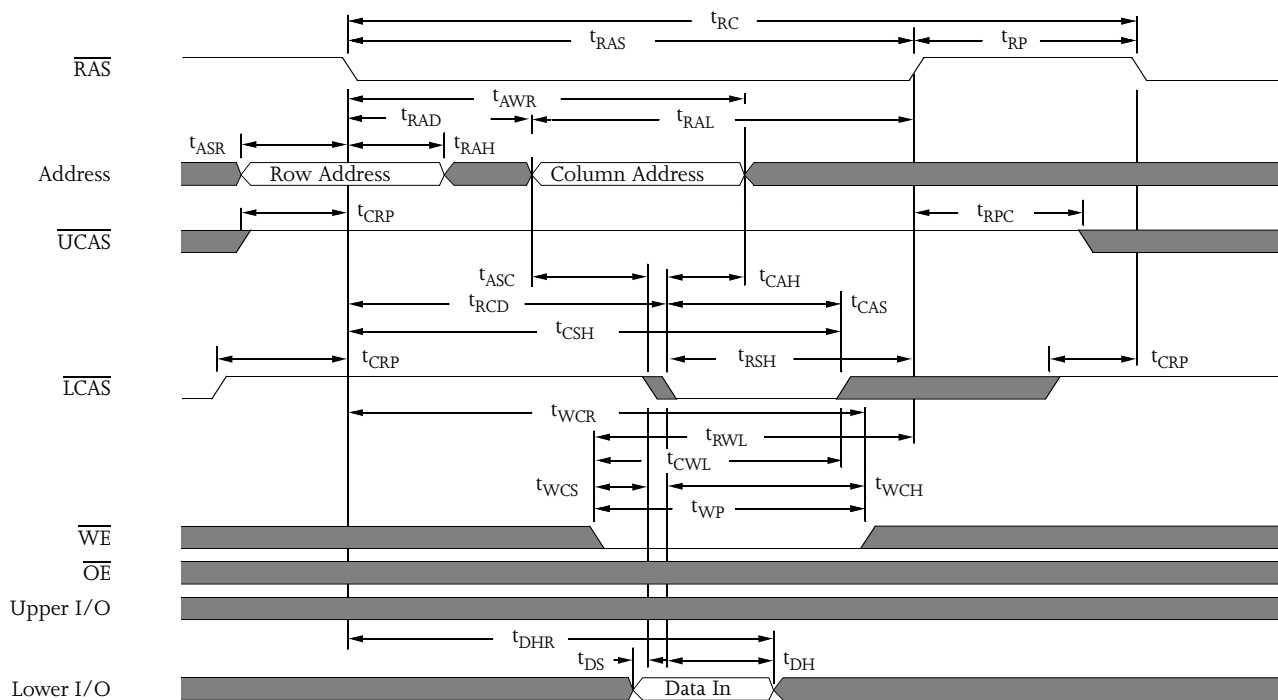

Write waveform

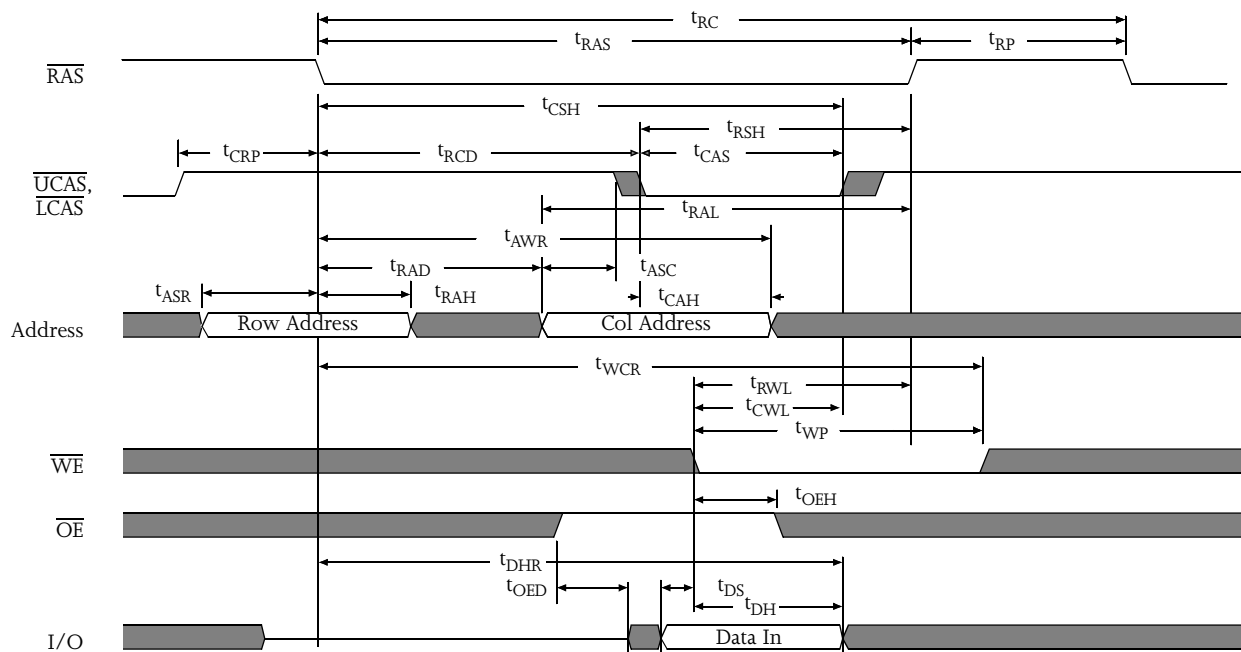



Upper byte write waveform

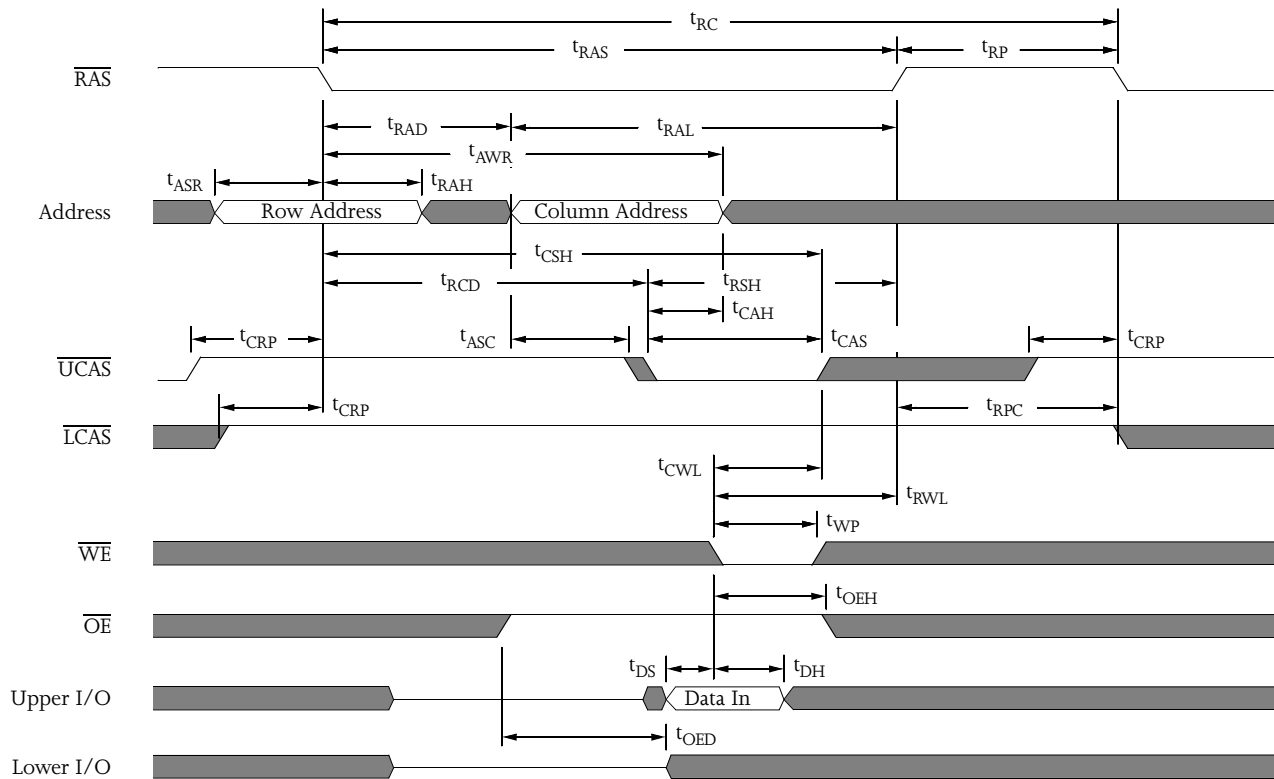



Lower byte write waveform

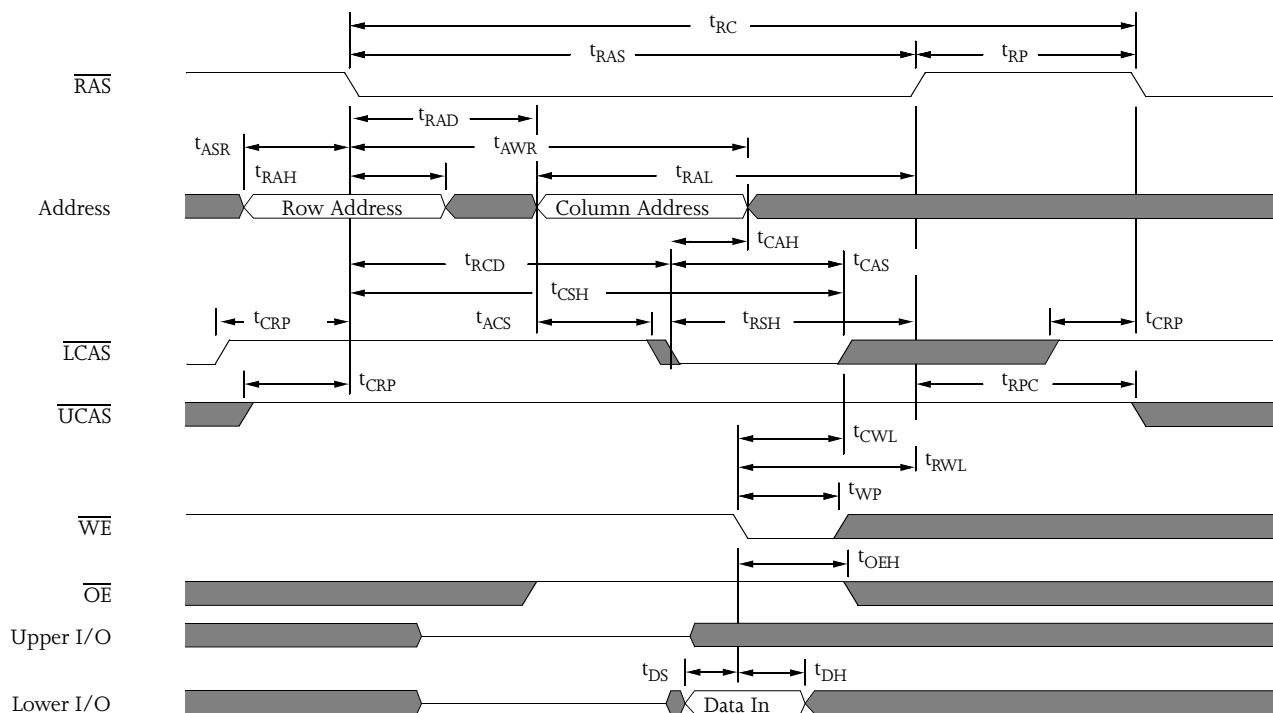

Read-modify-write waveform

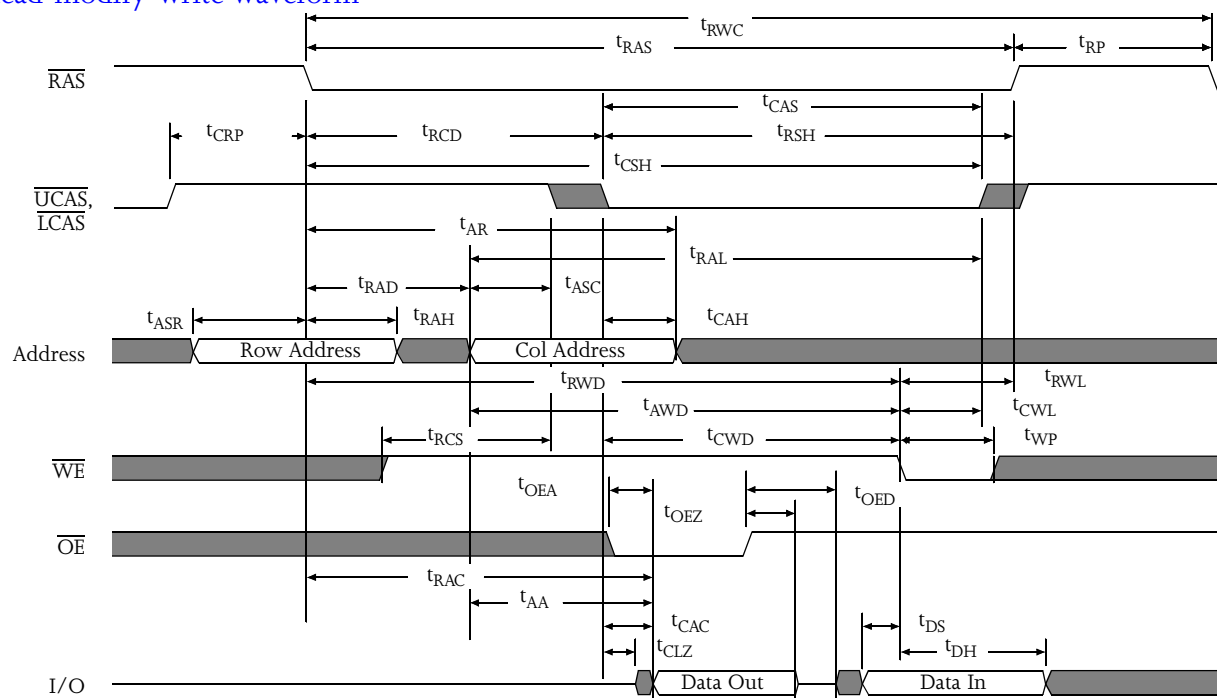



Upper byte read-modify-write waveform

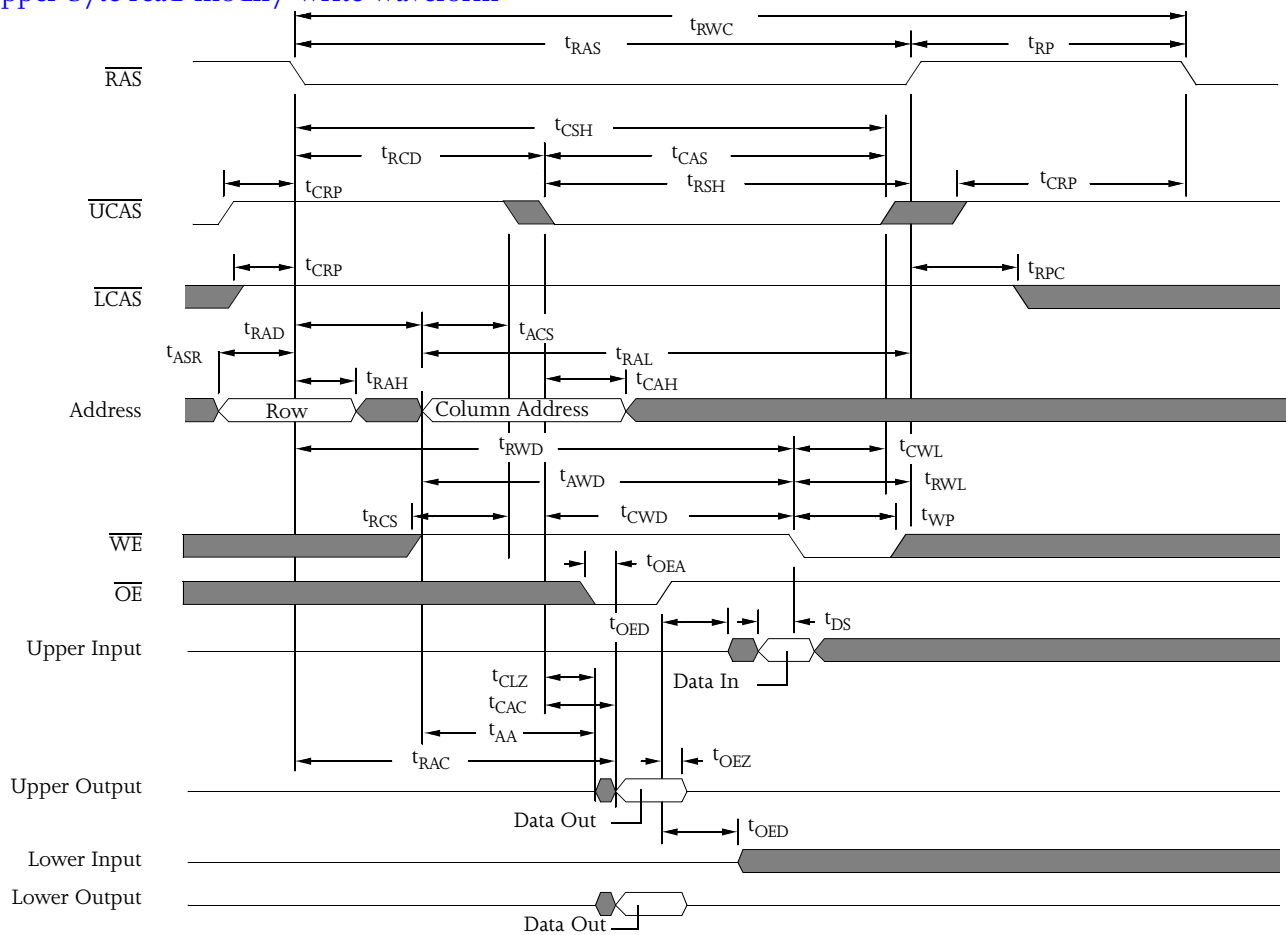



Lower byte read-modify write waveform

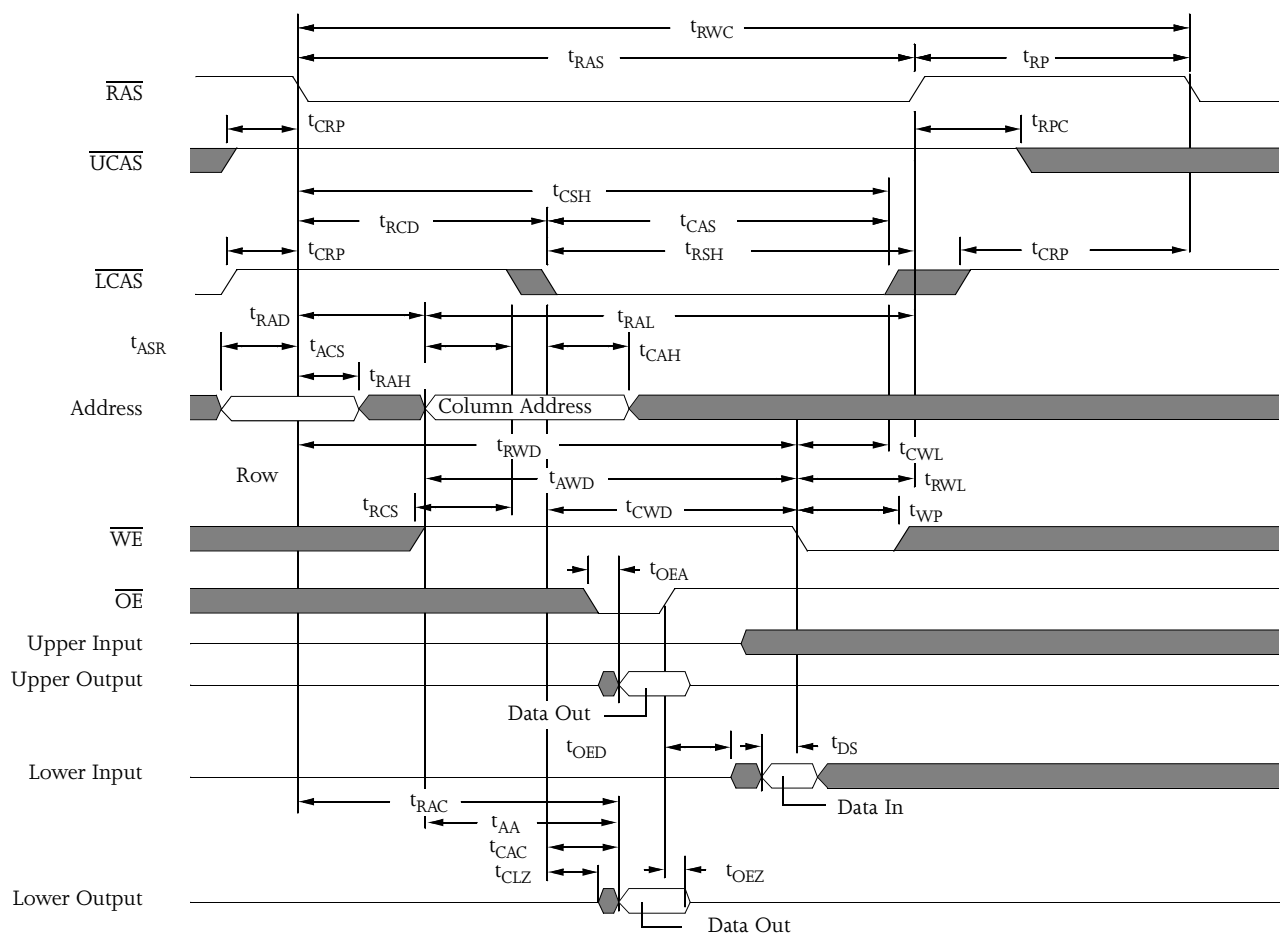



Fast page mode early write waveform

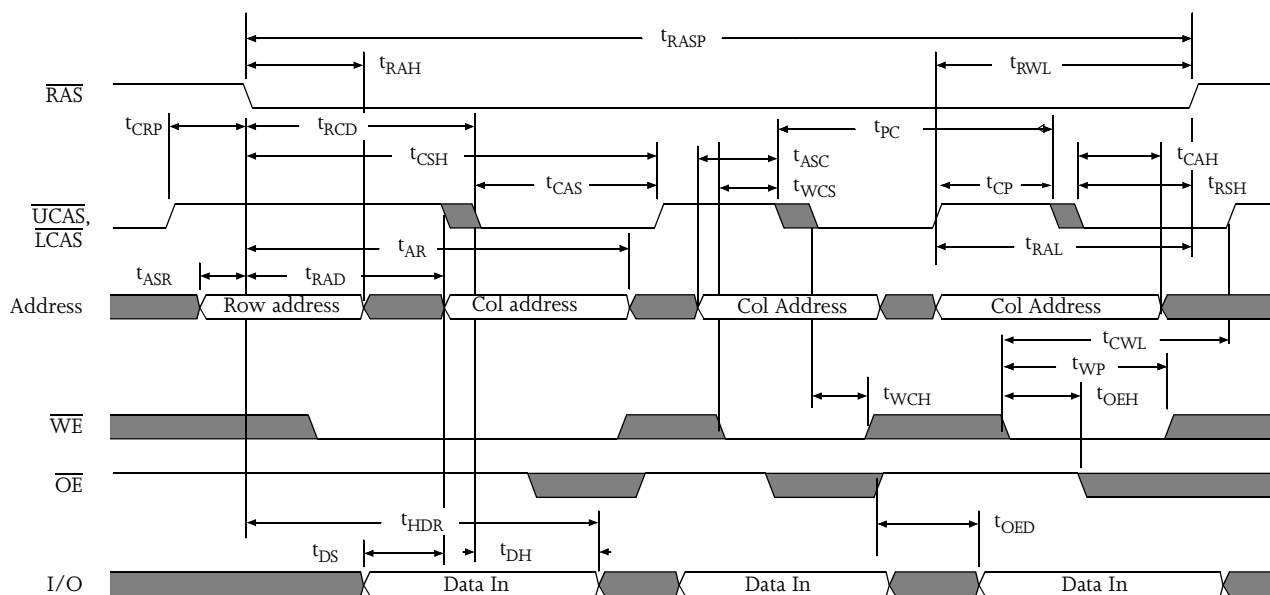

Fast page mode byte early write waveform

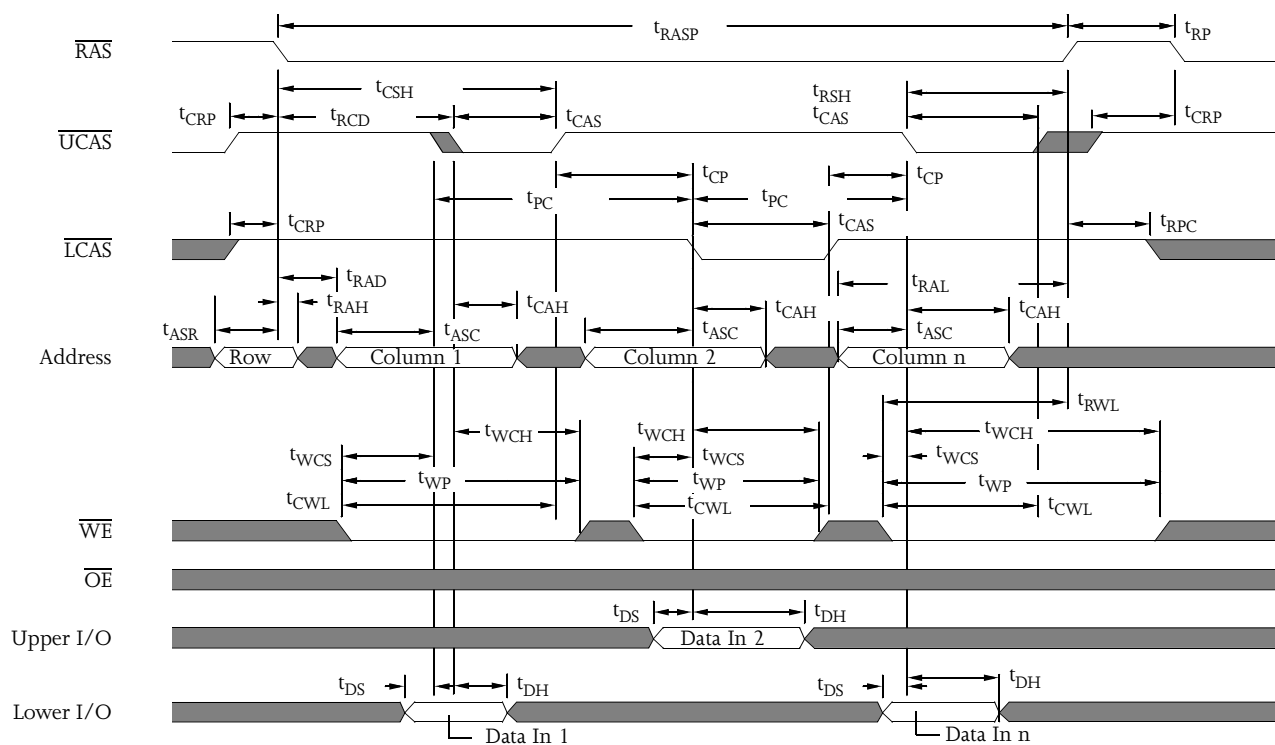



Fast page mode read-modify-write waveform

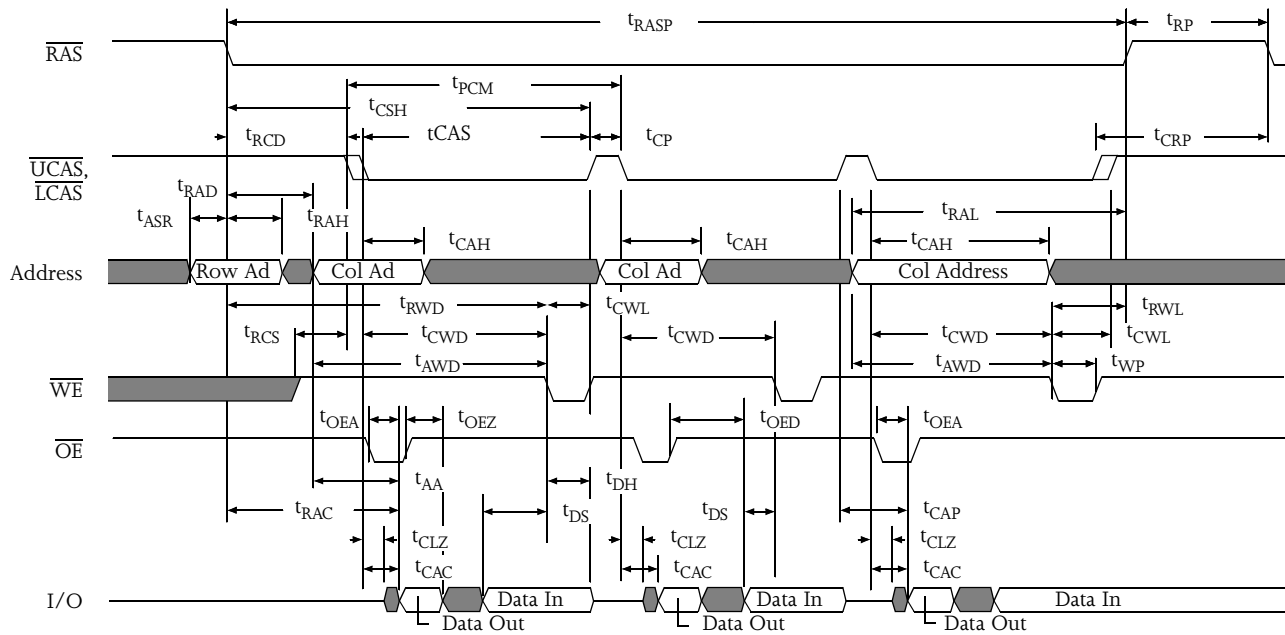

$\overline{\text{CAS}}$ -before- $\overline{\text{RAS}}$ refresh waveform

($\overline{\text{WE}} = V_{\text{IH}}$)

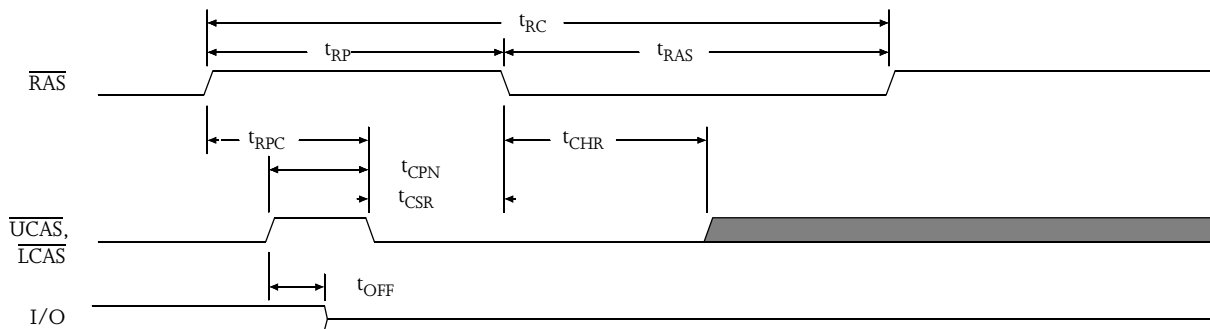

$\overline{\text{RAS}}$ -only refresh waveform

($\overline{\text{WE}} = \overline{\text{OE}} = V_{\text{IH}}$ or V_{IL})

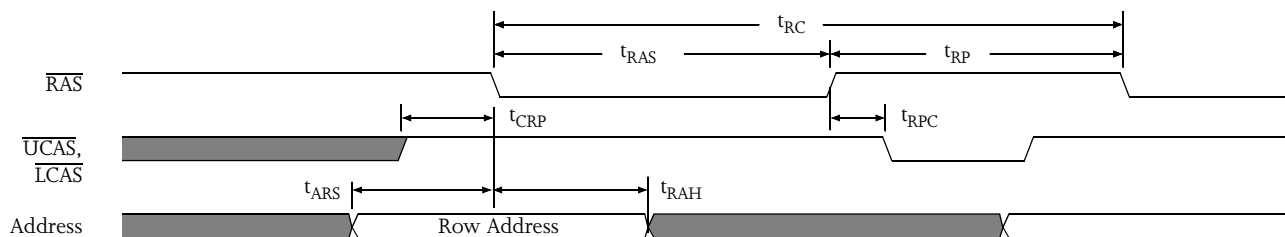



Fast page mode byte read-modify-write waveform

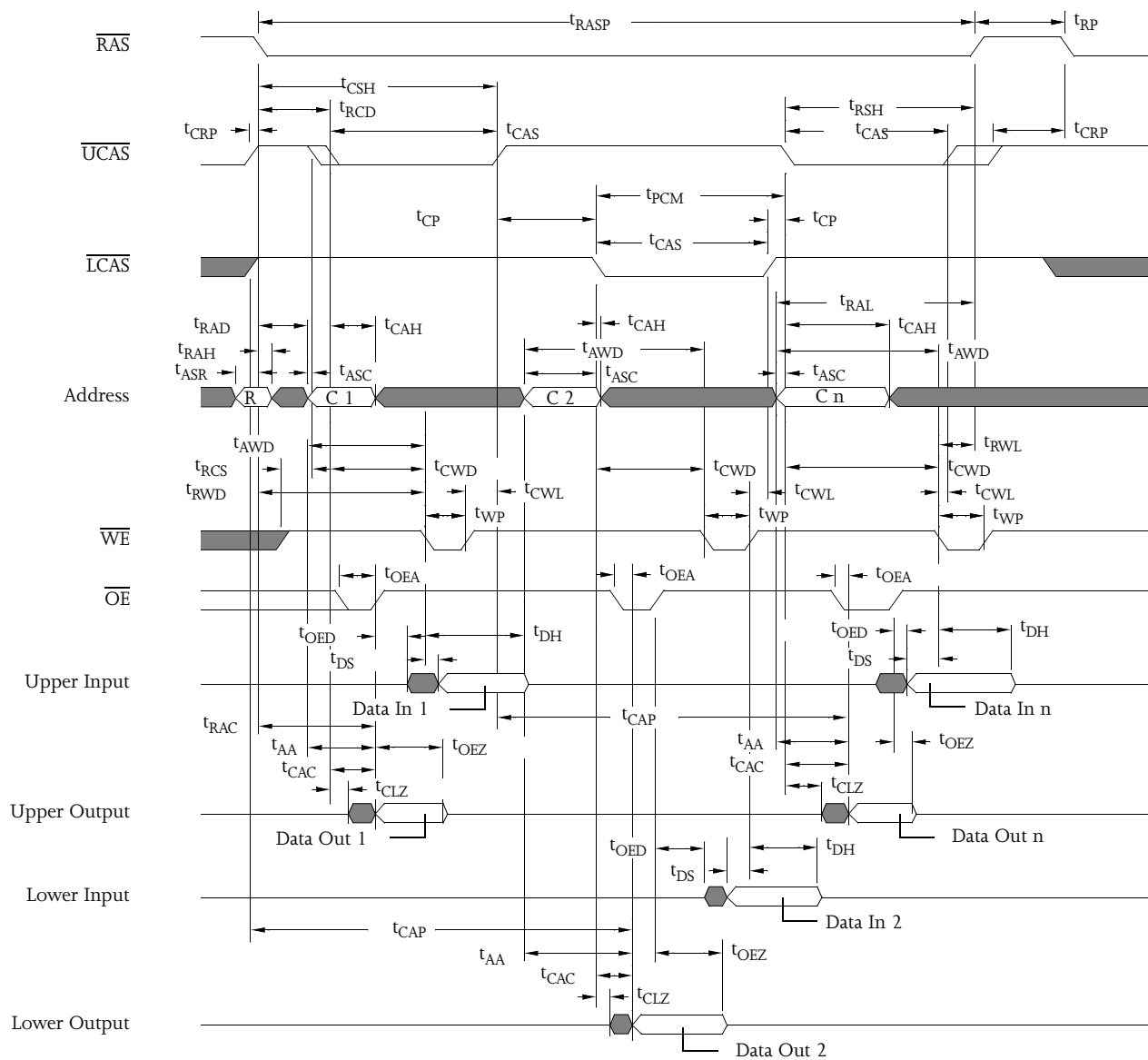



Hidden refresh waveform (read)

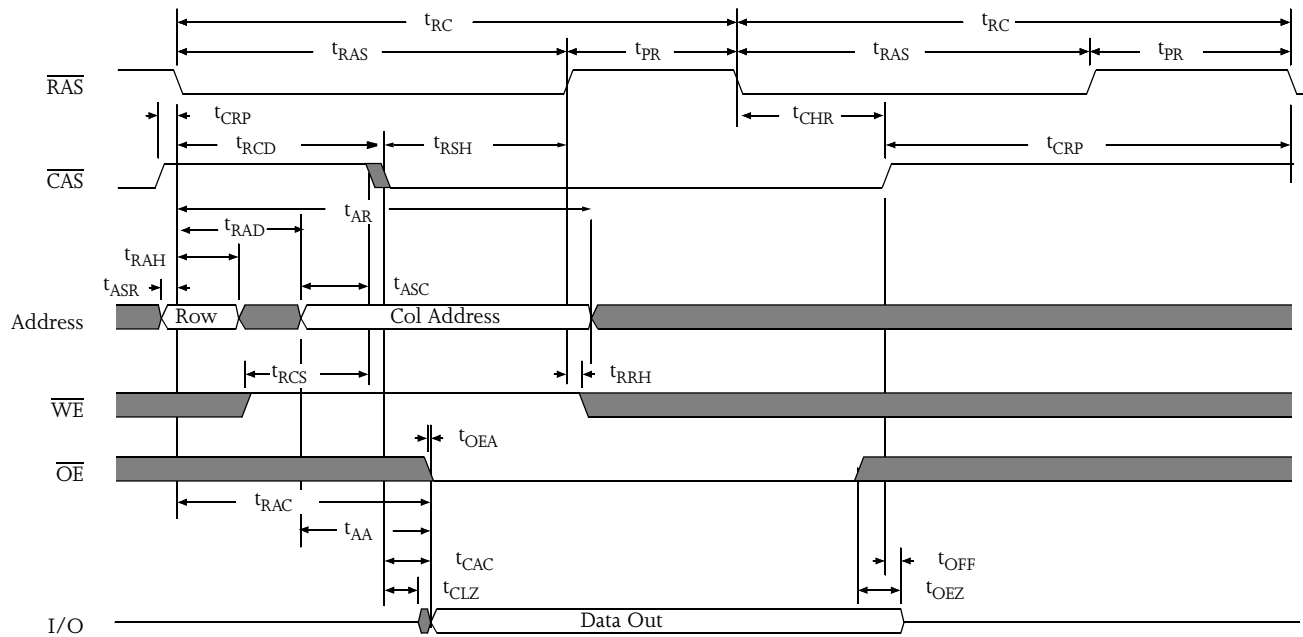

Hidden refresh waveform (write)

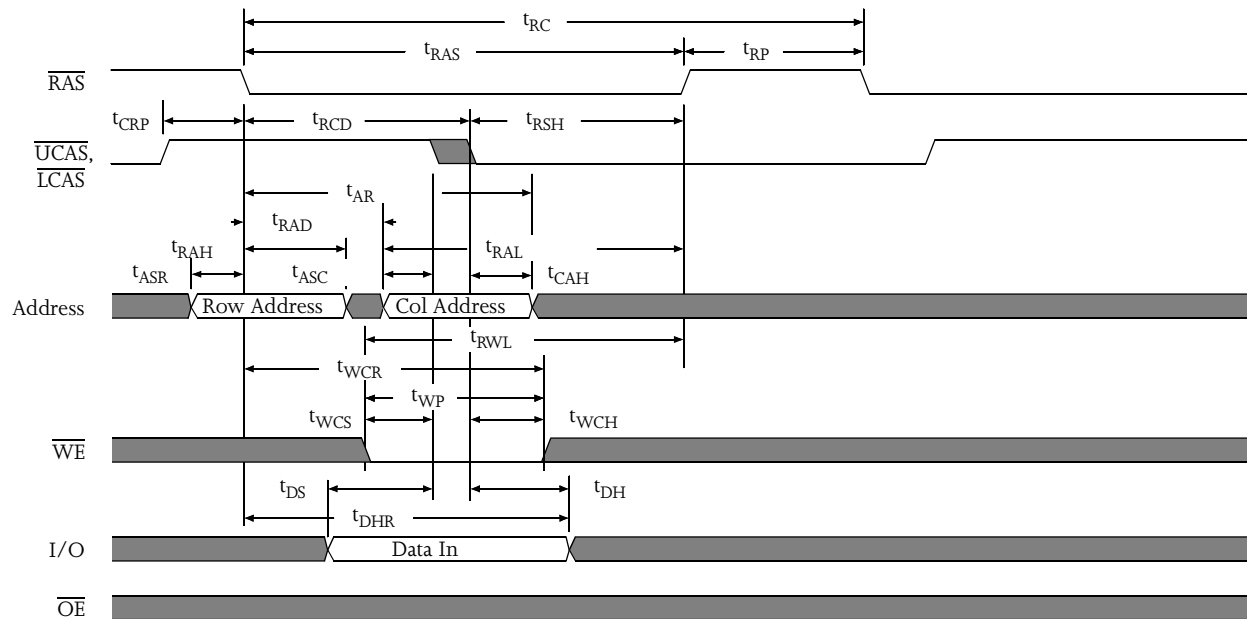



$\overline{\text{CAS}}$ before $\overline{\text{RAS}}$ refresh counter test waveform

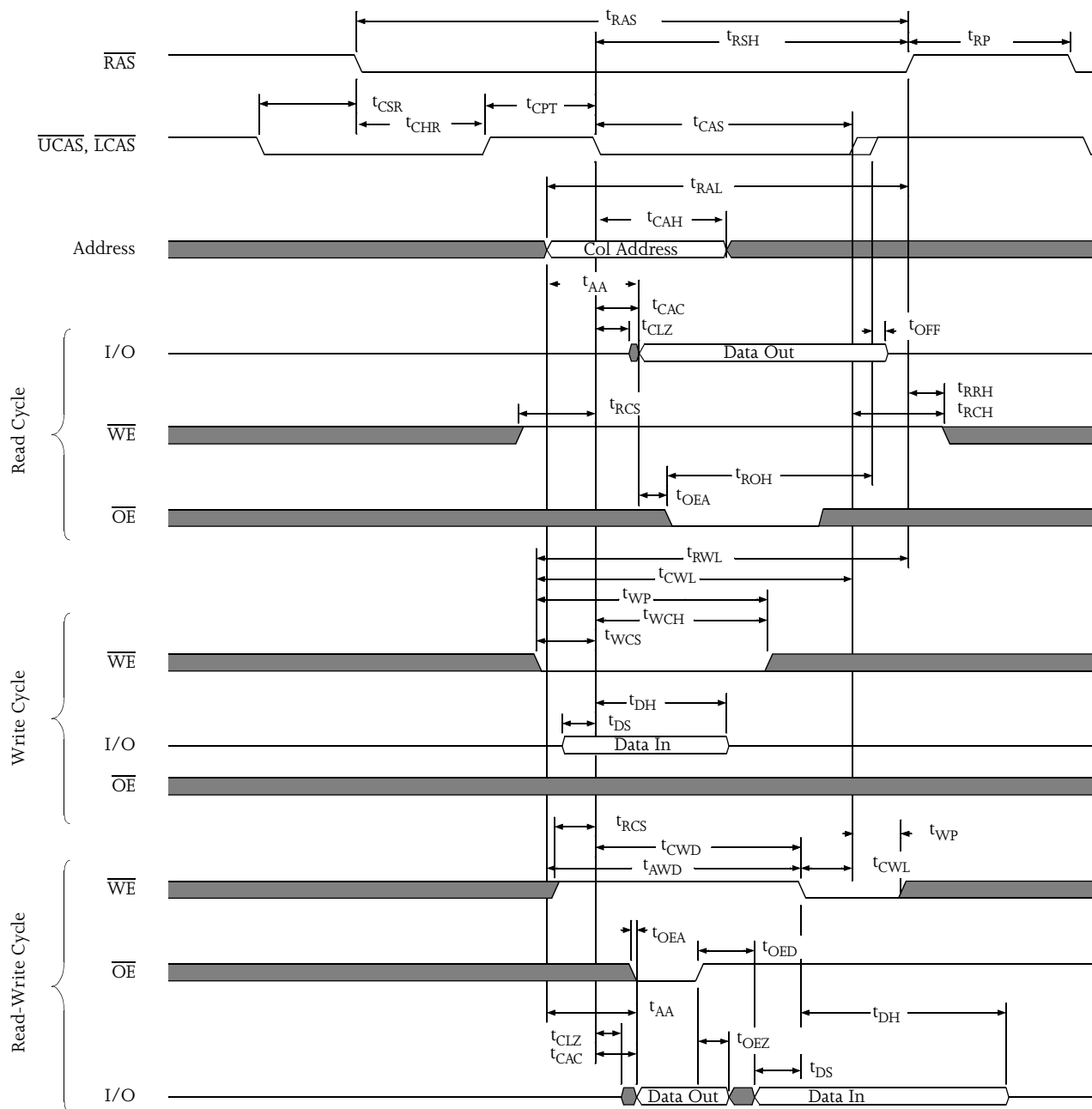



CAS-before-RAS self refresh cycle

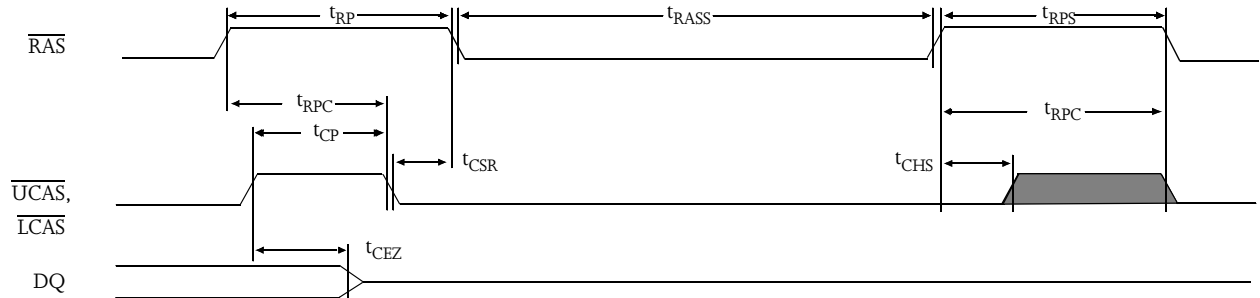

Typical AC and DC characteristics

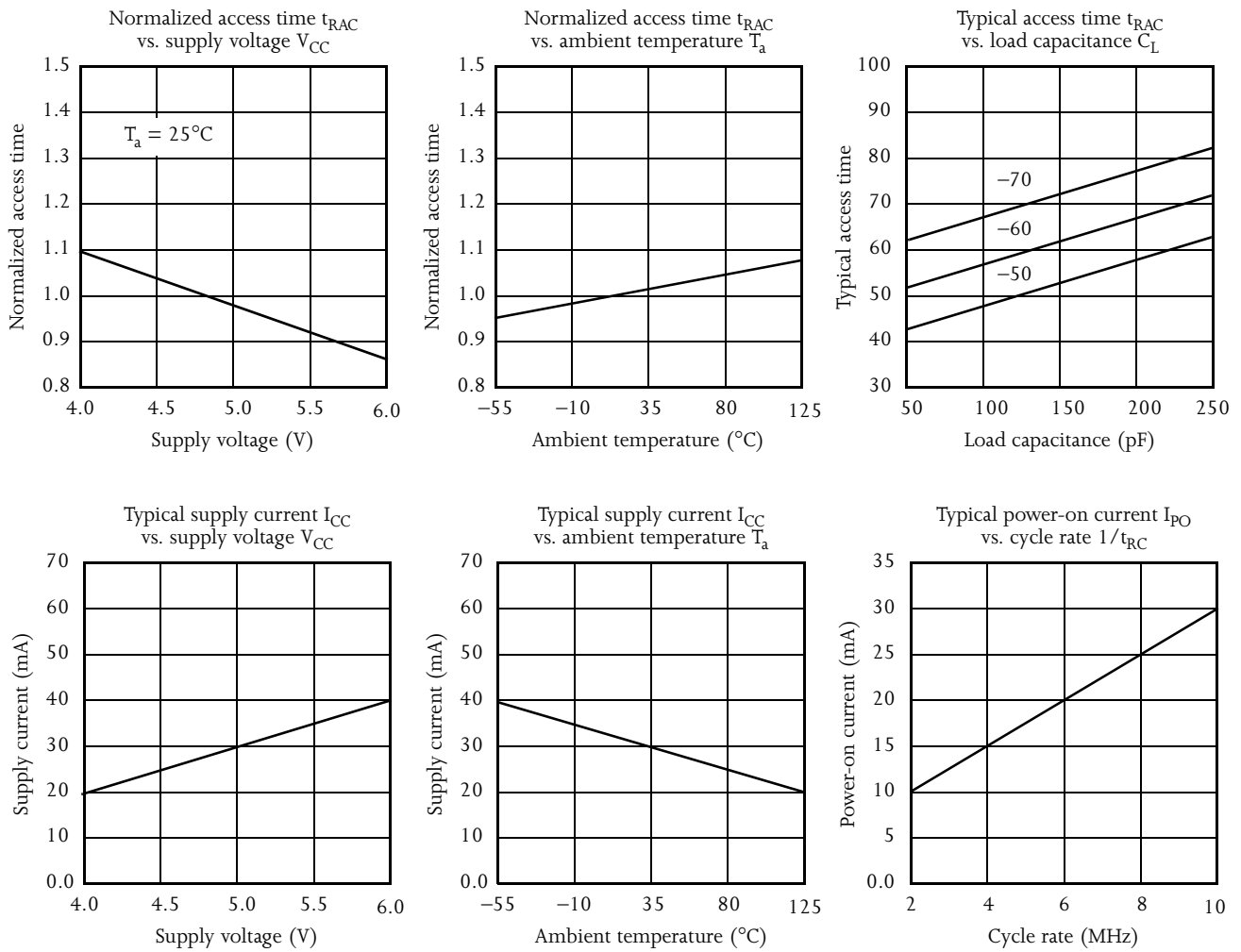

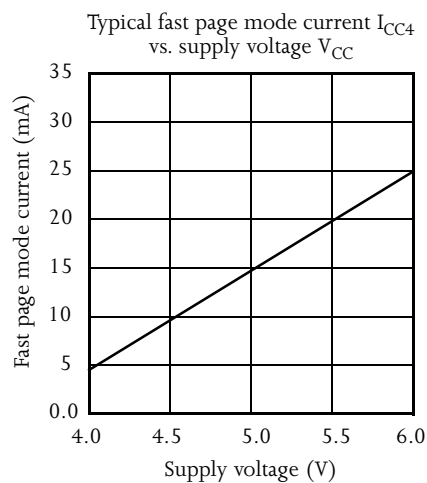
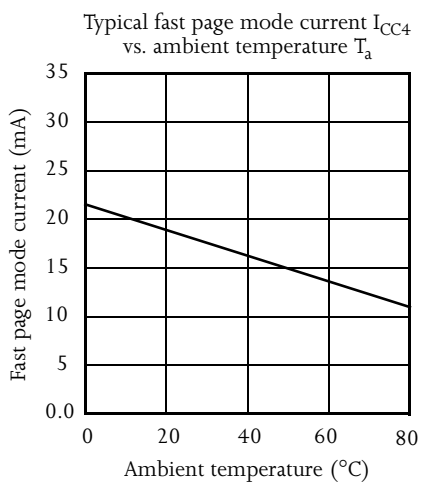
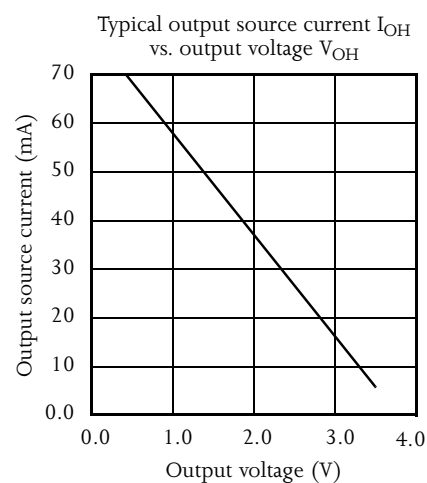
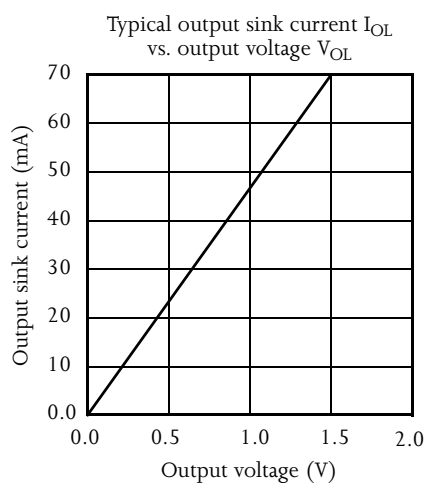
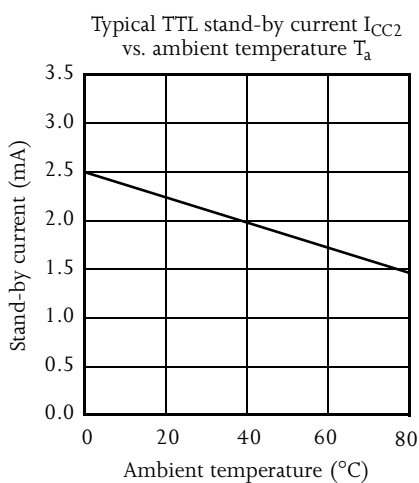
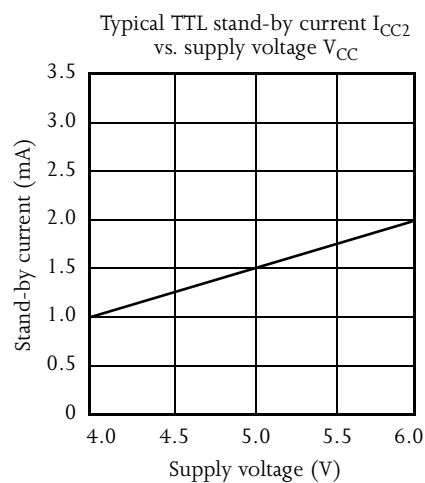
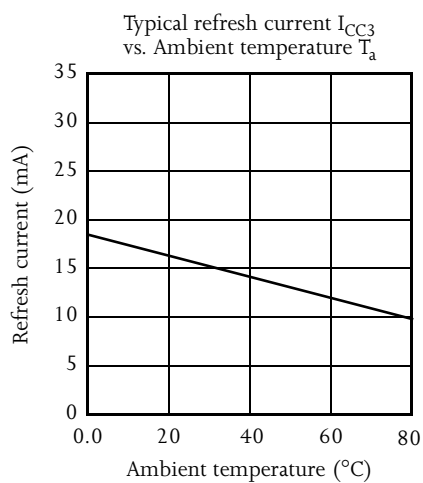
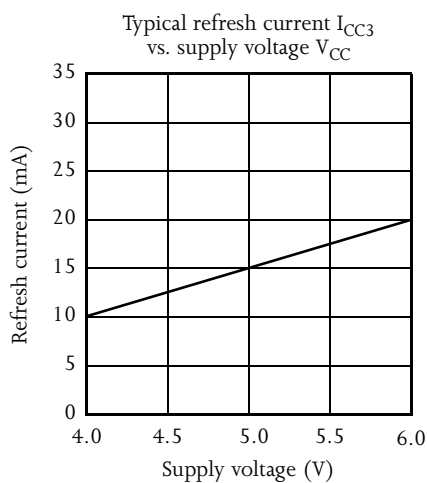



Package dimensions

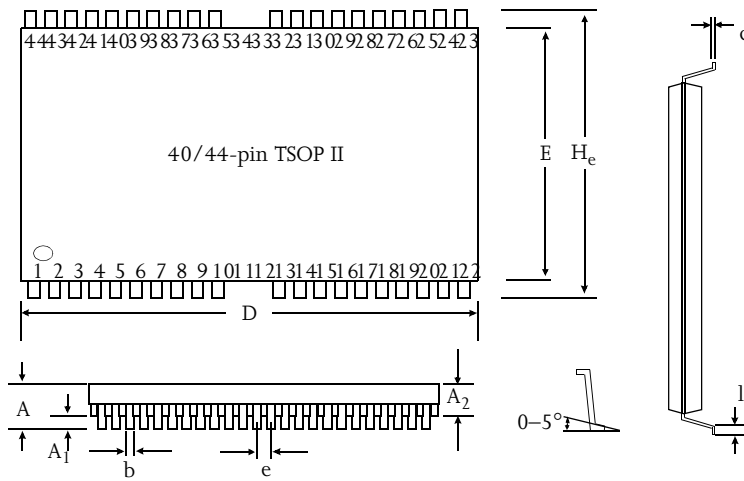

	44-pin TSOP II	
	Min (mm)	Max (mm)
A		1.2
A ₁	0.05	
A ₂	0.95	1.05
b	0.30	0.45
c	0.127 (typical)	
D	18.28	18.54
E	10.03	10.29
H _e	11.56	11.96
e	0.80 (typical)	
l	0.40	0.60

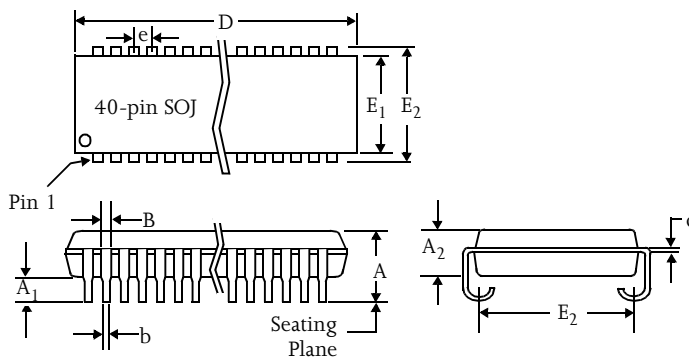

	40-pin SOJ 400 mil	
	Min	Max
A	0.128	0.148
A ₁	0.026	-
A ₂	1.105	1.115
B	0.026	0.032
b		0.020
c	0.007	0.013
D	1.020	1.035
E	0.370 (typical)	
E ₁	0.395	0.405
E ₂	0.435	0.445
e	0.050 (typical)	

Capacitance

(f = 1 MHz, T_a = Room Temperature, V_{CC} = 5V ±10%)

Parameter	Symbol	Signals	Test conditions	Max	Unit
Input capacitance	C _{IN1}	A0 to A8	V _{IN} = 0V	5	pF
	C _{IN2}	RAS, UCAS, LCAS, WE, OE	V _{IN} = 0V	7	pF
I/O capacitance	C _{I/O}	I/O0 to I/O15	V _{IN} = V _{OUT} = 0V	7	pF



Ordering codes

-25 ns	-30 ns	-35 ns	-50 ns
AS4C256K16F0-25JC	AS4C256K16F0-30JC	AS4C256K16F0-35JC	AS4C256K16F0-50JC
AS4C256K16F0-25JI	AS4C256K16F0-30JI	AS4C256K16F0-35JI	AS4C256K16F0-50JI
AS4C256K16F0-25TC	AS4C256K16F0-30TC	AS4C256K16F0-35TC	AS4C256K16F0-50TC
AS4C256K16F0-25TI	AS4C256K16F0-30TI	AS4C256K16F0-35TI	AS4C256K16F0-50TI

Part numbering system

AS4C	256K16F0	-XX	X	C/I
DRAM prefix	Device number	RAS access time	Package: J = Plastic SOJ, 400 mil, 40-pin T = TSOP II, 400 mil, 40/44-pin	Temperature Range: C= Commercial (0 °C to 70 °C) I= Industrial (-40°C to 85°C)