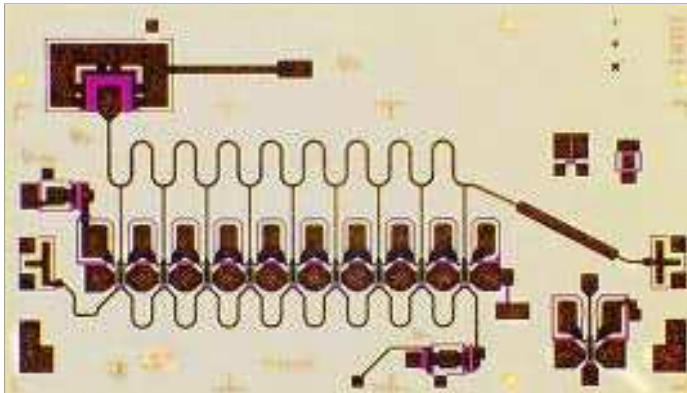

TGA8310-SCC

Low-Noise Amplifier

8310

- **2 to 20-GHz Frequency Range**
- **3.5-dB Noise Figure Midband**
- **1.4:1 Typical Input/Output SWR**
- **17.5-dBm Output Power at 1-dB Gain Compression**
- **9-dB Typical Gain**
- **4,115 x 2,362 x 0,102 mm (0.162 x 0.093 x 0.004 in.)**

PHOTO ENLARGEMENT**DESCRIPTION**

The TriQuint TGA8310 - SCC is a monolithic low - noise distributed amplifier, which operates from 2 to 20- GHz. Noise figure is typically 4 - dB. Nine 122- μm gatewidth FETs typically provide 17.5-dBm of output power at 1- dB gain compression and 9- dB typical small signal gain. Typical input return loss is 17-dB from 2 to 20-GHz. Typical output return loss is 20-dB. Ground is provided to the circuitry through vias to the backside metallization.

The TGA8310 - SCC low - noise distributed amplifier is suitable for a variety of wide - band electronic warfare systems such as radar warning receivers, electronic counter-measures, decoys, jammers, and phased array systems.

Bond pad and backside metallization is gold plated for compatibility with eutectic alloy attachment methods as well as the thermocompression and thermosonic wire-bonding processes. The TGA8310 - SCC is supplied in chip form and is readily assembled using automated equipment.

**TYPICAL
SMALL-SIGNAL
POWER GAIN**

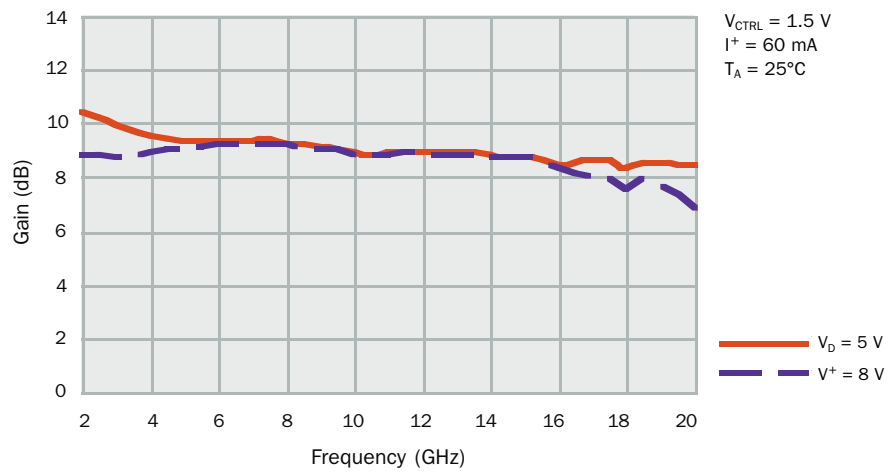

**TYPICAL
NOISE FIGURE**

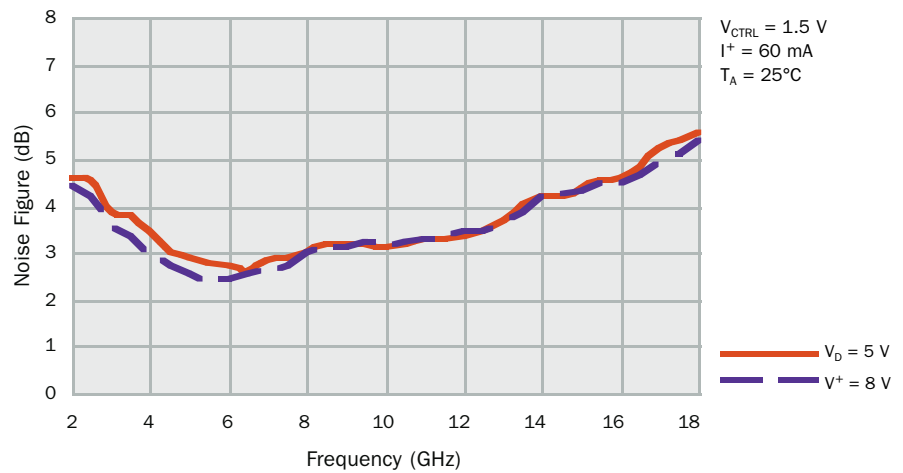

**TYPICAL
OUTPUT POWER
 P_{1dB}**

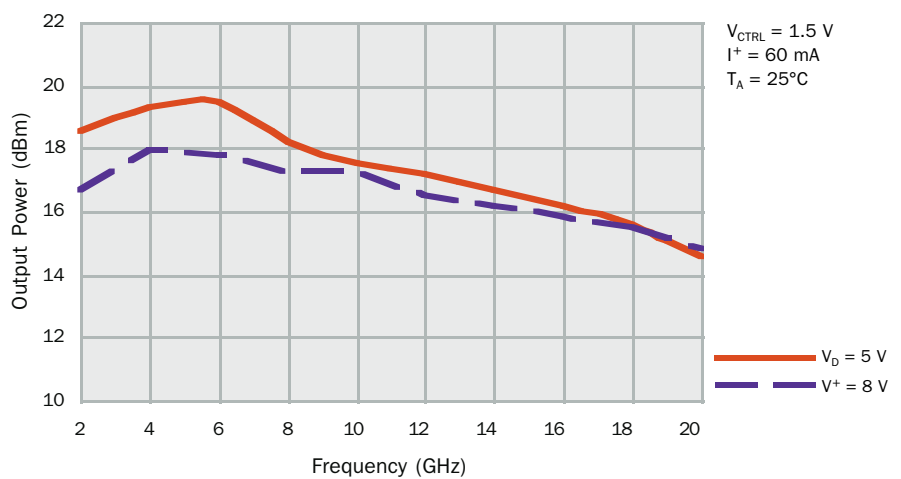

**TYPICAL
INPUT RETURN LOSS**

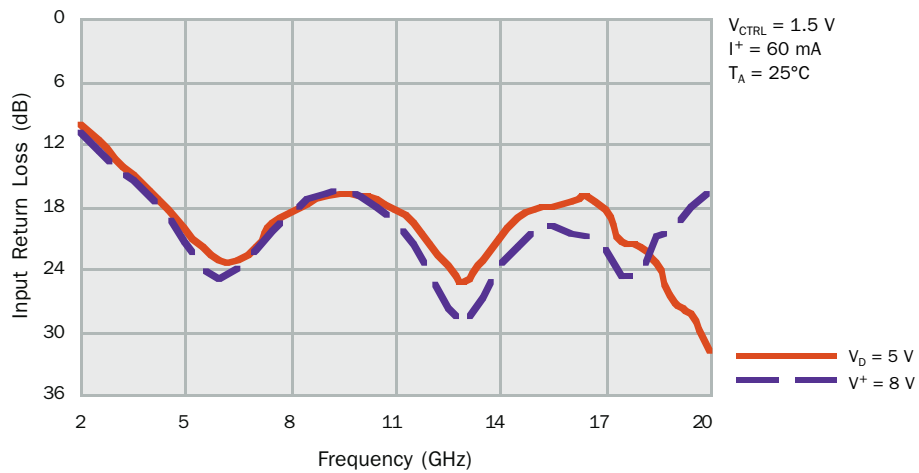

**TYPICAL
OUTPUT RETURN LOSS**

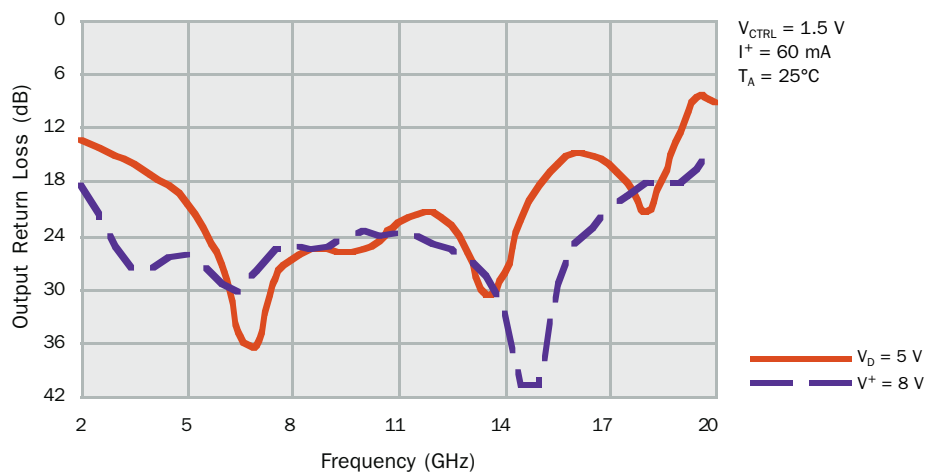

**ABSOLUTE
MAXIMUM RATINGS**

Drain supply voltage, V_D	9 V
Positive supply voltage, V^+	12 V
Positive supply voltage range with respect to negative supply voltage, $V^+ - V_{G1}$	0 V to 13 V
Positive supply voltage range with respect to gain control voltage, $V_{CTRL} - V^+$	0 V to -13 V
Negative supply voltage range, V_{G1}	-5 V to 0 V
Gain control voltage range, V_{CTRL}	-5 V to 4 V
Drain supply current, I_D	I_{DSS}
Positive supply current, I^+	188 mA
Power dissipation, P_D , at (or below) 25 °C base-plate temperature*	2.6 W
Input continuous wave power, P_{IN}	23 dBm
Operating channel temperature, T_{CH}^{**}	150 °C
Mounting temperature (30 sec), T_M	320 °C
Storage temperature range, T_{STG}	-65 to 150 °C

Ratings over operating channel temperature range, T_{CH} (unless otherwise noted)

Stresses beyond those listed under “Absolute Maximum Ratings” may cause permanent damage to the device. These are stress ratings only, and functional operation of the device at these or any other conditions beyond those indicated under “RF Characteristics” is not implied. Exposure to absolute maximum rated conditions for extended periods may affect device reliability.

* For operation above 25 °C base-plate temperature, derate linearly at the rate of 5.5 mW/ °C.

**Operating channel temperature directly affects the device MTF. For maximum life, it is recommended that channel temperature be maintained at the lowest possible level.

TYPICAL S-PARAMETERS

Frequency (GHz)	S ₁₁		S ₂₁		S ₁₂		S ₂₂		GAIN (dB)
	MAG	ANG(°)	MAG	ANG(°)	MAG	ANG(°)	MAG	ANG(°)	
2.0	0.31	-154	3.32	119	0.009	61	0.22	-19	10.4
2.5	0.26	-175	3.23	96	0.010	32	0.19	-62	10.2
3.0	0.21	169	3.13	75	0.011	14	0.17	-98	9.9
3.5	0.18	155	3.06	54	0.012	-6	0.16	-132	9.7
4.0	0.15	145	3.00	35	0.013	-23	0.14	-162	9.6
4.5	0.12	137	2.97	16	0.014	-42	0.12	169	9.4
5.0	0.10	134	2.93	-3	0.014	-59	0.10	143	9.3
5.5	0.08	135	2.93	-22	0.016	-76	0.07	116	9.3
6.0	0.07	143	2.92	-41	0.018	-96	0.04	87	9.3
6.5	0.07	153	2.93	-60	0.019	-115	0.02	44	9.3
7.0	0.08	162	2.94	-79	0.021	-133	0.02	-92	9.4
7.5	0.10	162	2.95	-99	0.022	-153	0.04	-143	9.4
8.0	0.12	157	2.91	-118	0.024	-170	0.05	-170	9.3
8.5	0.13	152	2.90	-138	0.025	173	0.05	164	9.2
9.0	0.14	145	2.85	-157	0.027	156	0.05	133	9.1
9.5	0.14	137	2.83	-176	0.028	140	0.05	95	9.1
10.0	0.14	127	2.80	165	0.029	123	0.05	52	8.9
10.5	0.14	116	2.77	146	0.029	109	0.06	17	8.8
11.0	0.12	109	2.80	127	0.032	89	0.07	-25	8.9
11.5	0.11	100	2.80	107	0.032	73	0.08	-54	9.0
12.0	0.08	99	2.80	88	0.033	56	0.08	-82	8.9
12.5	0.07	107	2.80	68	0.035	37	0.07	-109	8.9
13.0	0.06	128	2.79	48	0.035	18	0.05	-141	8.9
13.5	0.07	147	2.79	28	0.037	0	0.03	153	8.9
14.0	0.09	150	2.77	8	0.038	-21	0.04	53	8.8
14.5	0.11	144	2.74	-13	0.039	-41	0.08	13	8.7
15.0	0.12	130	2.73	-33	0.041	-58	0.12	-14	8.7
15.5	0.12	121	2.70	-54	0.044	-76	0.16	-42	8.6
16.0	0.13	112	2.65	-74	0.046	-96	0.18	-70	8.5
16.5	0.14	99	2.66	-94	0.049	-115	0.18	-99	8.5
17.0	0.12	87	2.70	-115	0.052	-134	0.16	-131	8.6
17.5	0.09	81	2.71	-138	0.056	-155	0.13	-166	8.7
18.0	0.08	95	2.61	-159	0.053	-175	0.08	145	8.3
18.5	0.07	79	2.68	-180	0.056	168	0.13	57	8.6
19.0	0.04	88	2.67	156	0.058	142	0.24	-25	8.5
19.5	0.04	92	2.65	133	0.054	119	0.37	-87	8.5
20.0	0.03	86	2.64	110	0.051	102	0.34	-149	8.4

$$T_A = 25^\circ\text{C}, V_D = 5 \text{ V}, V_{\text{CTRL}} = 1.5 \text{ V}, I^* = 60 \text{ mA}$$

Reference planes for S-parameter data include bond wires as specified in the "Recommended Assembly Diagram." The S-parameters are also available on floppy disk and the world wide web.

TYPICAL S-PARAMETERS

Frequency (GHz)	S ₁₁		S ₂₁		S ₁₂		S ₂₂		GAIN (dB)
	MAG	ANG(°)	MAG	ANG(°)	MAG	ANG(°)	MAG	ANG(°)	
2.0	0.28	-155	2.76	108	0.007	37	0.12	-133	8.8
2.5	0.23	-178	2.75	90	0.008	19	0.08	-152	8.8
3.0	0.20	165	2.74	72	0.010	4	0.05	180	8.8
3.5	0.17	151	2.77	53	0.011	-12	0.04	134	8.8
4.0	0.14	140	2.79	35	0.012	-28	0.04	86	8.9
4.5	0.11	133	2.83	16	0.013	-45	0.05	55	9.0
5.0	0.08	132	2.84	-3	0.015	-63	0.05	32	9.1
5.5	0.06	138	2.87	-22	0.016	-80	0.04	8	9.2
6.0	0.06	154	2.88	-41	0.018	-99	0.03	-28	9.2
6.5	0.06	166	2.90	-60	0.019	-117	0.03	-82	9.2
7.0	0.08	165	2.88	-79	0.021	-136	0.04	-128	9.2
7.5	0.09	165	2.91	-98	0.022	-152	0.05	-157	9.3
8.0	0.12	160	2.88	-118	0.024	-171	0.06	173	9.2
8.5	0.13	154	2.87	-137	0.026	172	0.05	143	9.2
9.0	0.15	148	2.84	-157	0.027	156	0.05	111	9.1
9.5	0.15	141	2.81	-176	0.028	140	0.06	79	9.0
10.0	0.14	131	2.78	165	0.029	124	0.07	52	8.9
10.5	0.13	122	2.76	146	0.030	104	0.06	27	8.8
11.0	0.11	112	2.78	128	0.031	91	0.07	1	8.9
11.5	0.08	105	2.79	108	0.032	73	0.06	-29	8.9
12.0	0.06	105	2.76	88	0.032	55	0.06	-58	8.8
12.5	0.04	115	2.77	69	0.033	38	0.05	-85	8.9
13.0	0.03	147	2.76	49	0.034	20	0.05	-113	8.8
13.5	0.05	163	2.76	29	0.035	1	0.04	-147	8.8
14.0	0.06	161	2.75	8	0.037	-19	0.02	-173	8.8
14.5	0.08	150	2.74	-12	0.039	-39	0.01	163	8.7
15.0	0.10	133	2.72	-33	0.040	-59	0.01	-17	8.7
15.5	0.10	116	2.71	-54	0.042	-78	0.03	-37	8.7
16.0	0.09	103	2.60	-76	0.043	-96	0.06	-60	8.3
16.5	0.09	90	2.54	-96	0.046	-112	0.07	-76	8.1
17.0	0.08	65	2.52	-117	0.048	-131	0.09	-91	8.0
17.5	0.06	45	2.49	-139	0.050	-151	0.11	-112	7.9
18.0	0.06	81	2.39	-158	0.047	-170	0.13	-129	7.6
18.5	0.09	63	2.50	-179	0.051	177	0.12	-138	8.0
19.0	0.10	72	2.45	158	0.054	155	0.12	-135	7.8
19.5	0.13	85	2.34	133	0.053	132	0.15	-120	7.4
20.0	0.15	96	2.20	110	0.053	112	0.21	-118	6.8

$$T_A = 25^\circ\text{C}, V^+ = 8\text{ V}, V_{\text{CTRL}} = 1.5\text{ V}, I^+ = 60\text{ mA}$$

Reference planes for S-parameter data include bond wires as specified in the "Recommended Assembly Diagram."

RF CHARACTERISTICS

PARAMETER		TEST CONDITIONS		TYP	UNIT
G _P	Small-signal power gain	f = 2 to 20 GHz	V _D = 5 V	9.0	dB
			V ⁺ = 8 V	8.5	
NF	Noise figure	f = 2 GHz	V _D = 5 V	4.6	dB
			V ⁺ = 8 V	4.4	
		f = 6 GHz	V _D = 5 V	2.7	
			V ⁺ = 8 V	2.5	
		f = 10 GHz	V _D = 5 V	3.1	
			V ⁺ = 8 V	3.2	
		f = 18 GHz	V _D = 5 V	5.6	
			V ⁺ = 8 V	5.4	
SWR(in)	Input standing wave ratio	f = 2 to 20 GHz	V _D = 5 V	1.4:1	-
			V ⁺ = 8 V	1.4:1	
SWR(out)	Output standing wave ratio	f = 2 to 20 GHz	V _D = 5 V	1.4:1	-
			V ⁺ = 8 V	1.4:1	
P _{1dB}	Output power at 1-dB gain compression	f = 2 to 20 GHz	V _D = 5 V	17.5	dBm
			V ⁺ = 8 V	16.5	
IP ₃	Output third-order intercept point	f = 2 GHz	V _D = 5 V	29.5	dBm
		f = 6 GHz		27.0	
		f = 9 GHz		27.5	
		f = 12 GHz		26.5	
		f = 18 GHz		27.0	
Output second-order intercept point		f _o = 2 GHz	V _D = 5 V	32.5	dBm
		f _o = 4 GHz		29.5	
		f _o = 6 GHz		29.0	
		f _o = 9 GHz		28.0	
Output third harmonic at 1-dB gain compression		f _o = 2 GHz	V _D = 5 V	-29.0	dBc*
		f _o = 4 GHz		-24.5	
		f _o = 6 GHz		-19.5	
Output second harmonic at 1-dB gain compression		f _o = 2 GHz	V _D = 5 V	-18.0	dBc*
		f _o = 4 GHz		-15.0	
		f _o = 6 GHz		-13.5	
		f _o = 9 GHz		-15.5	

$$V_D = 5 \text{ V}, V_{\text{CTRL}} = 1.5 \text{ V}, I^+ = 60 \text{ mA}, T_A = 25^\circ\text{C}$$

* Unit dBc applies to decibels with respect to the carrier or fundamental frequency f_o.

DC CHARACTERISTICS

PARAMETER	TEST CONDITIONS	MIN	MAX	UNIT	
I _{DSS}	Zero-gate-voltage drain current at saturation	V _{DS} = 0.5 V to 3.5 V, V _{GS} = 0	97	292	mA

$$T_A = 25^\circ\text{C}$$

V_{DS} for I_{DSS} is the drain voltage between 0.5 V and 3.5 V at which drain current is highest at dc autoprobe.

THERMAL INFORMATION

PARAMETER	TEST CONDITIONS		NOM	UNIT	
R _{JC}	Thermal resistance (channel to backside)	V _{CTRL} = 1.5 V,	V ⁺ = 8 V	12	°C/W
		I ⁺ = 60 mA	V _D = 5 V	20	

EQUIVALENT SCHEMATIC

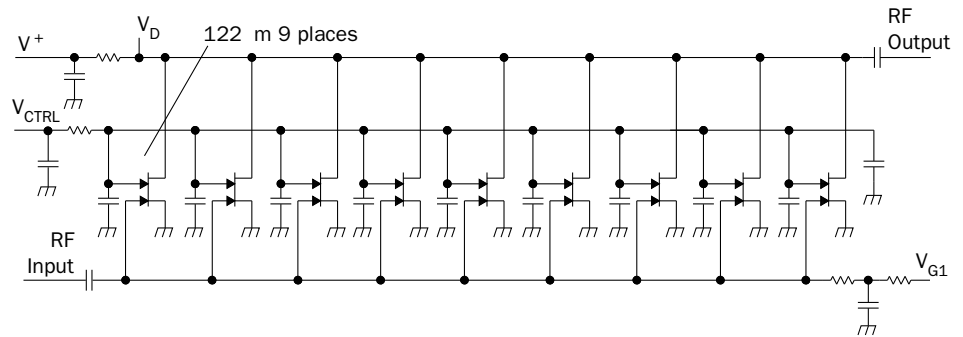

TYPICAL BIAS NETWORK

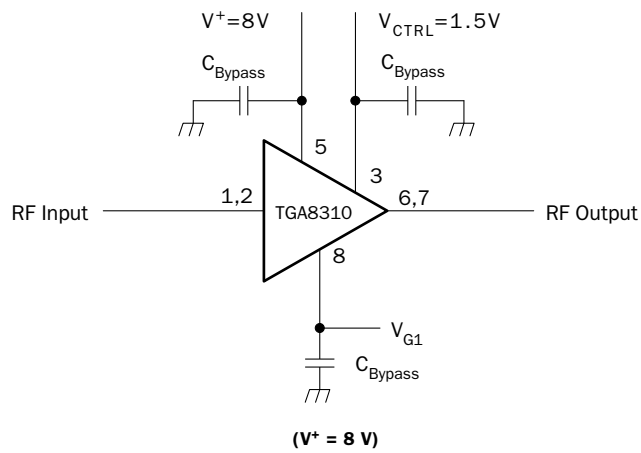

TYPICAL BIAS NETWORK

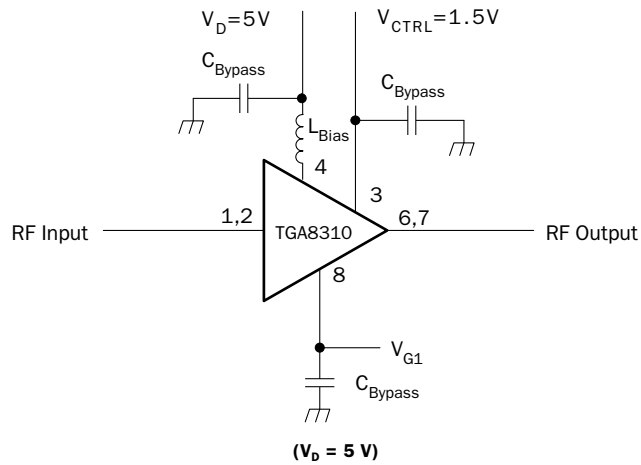

**RECOMMENDED
ASSEMBLY DIAGRAM**
8 Volt Bias

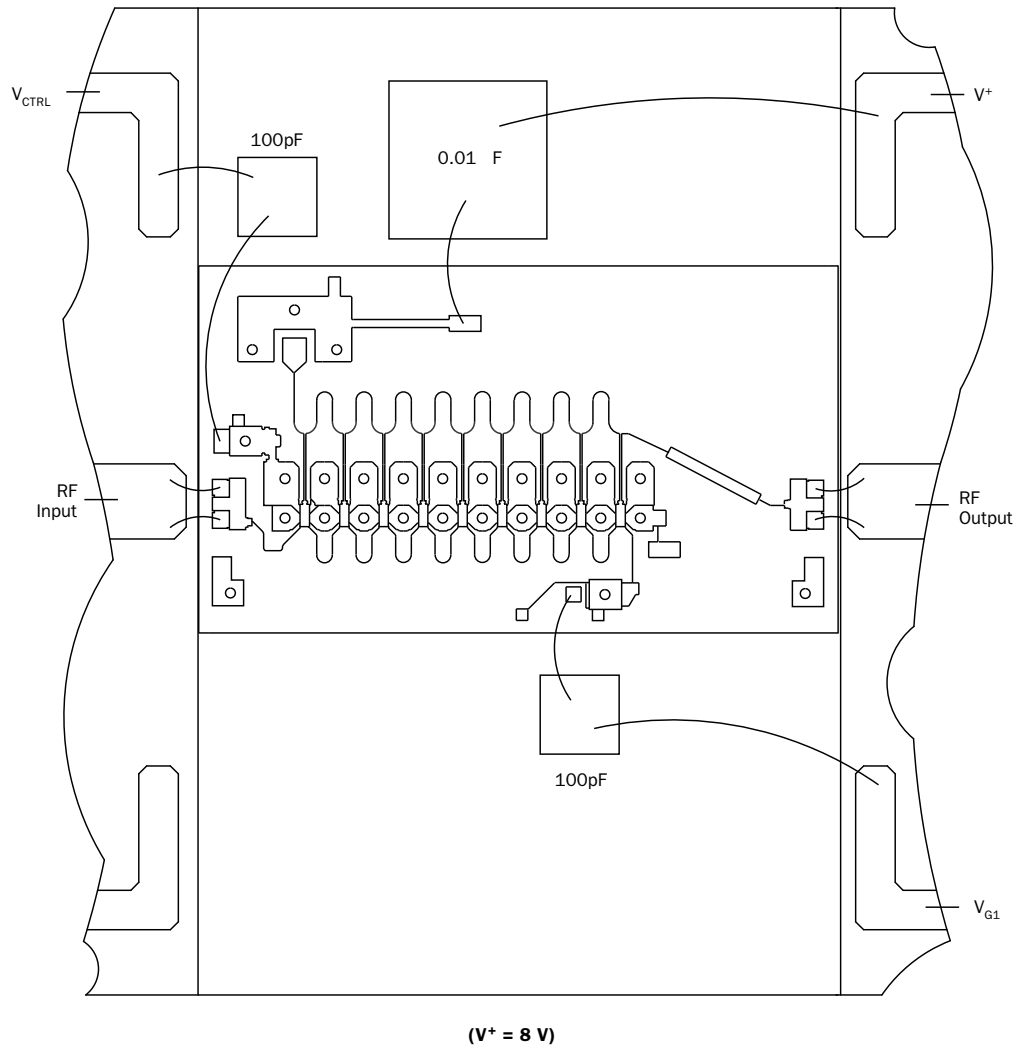

RF connections: Bond using two 1-mil diameter, 20 to 25-mil length gold bond wires at both RF Input and RF Output for optimum RF performance.

Close placement of external components is essential to stability.

**RECOMMENDED
ASSEMBLY DIAGRAM**
5 Volt Bias

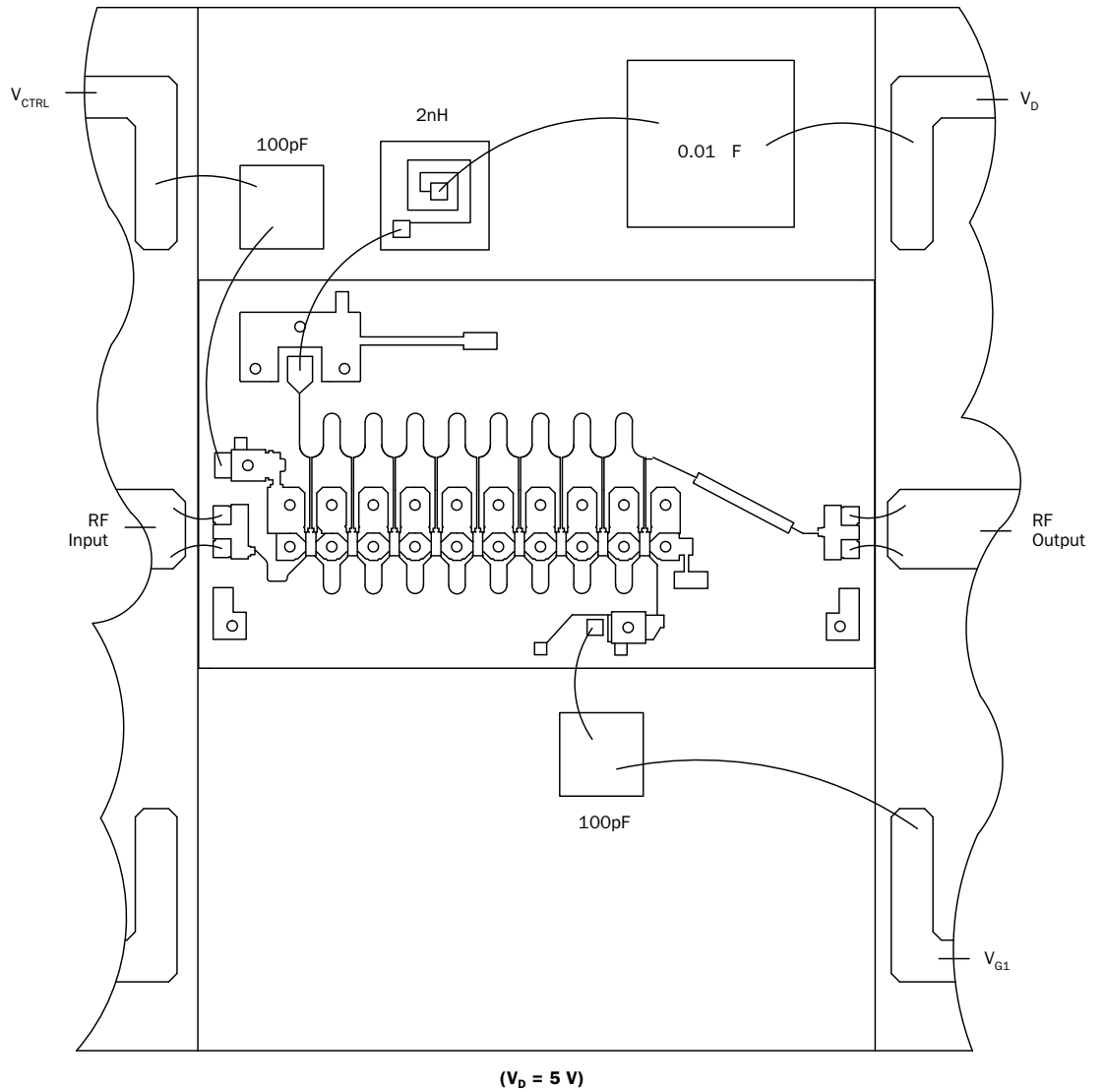

The 2-nH thin-film network coil is TI part number 3022039-1.

RF connections: Bond using two 1-mil diameter, 20 to 25-mil length gold bond wires at both RF Input and RF Output for optimum RF performance.

Close placement of external components is essential to stability.

MECHANICAL DRAWING

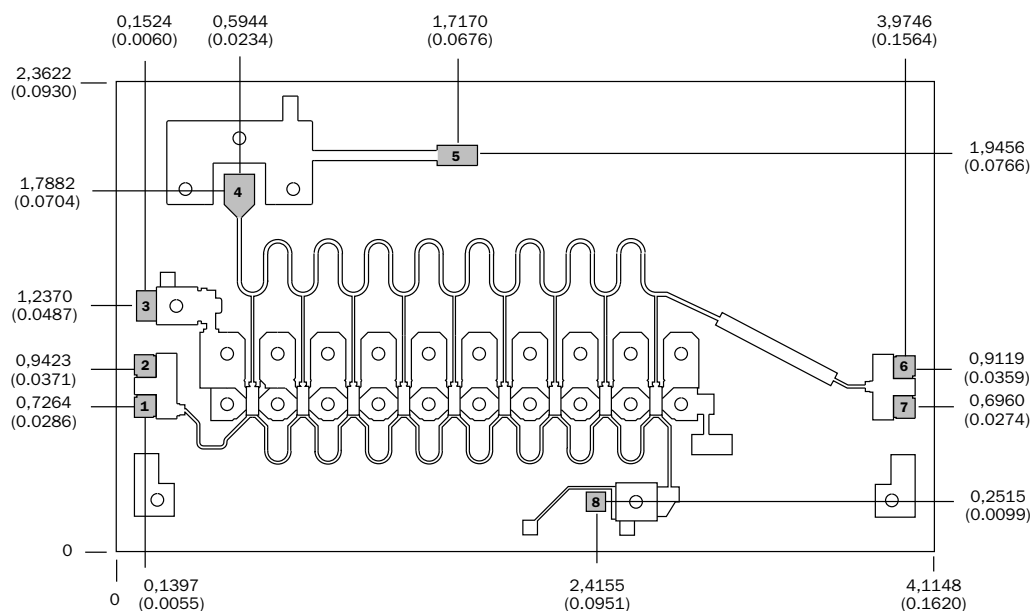

Units: millimeters (inches)

Thickness: 0,1016 (0.004) (reference only)

Chip edge to bond pad dimensions are shown to center of bond pad.

Chip size $\pm 0,0508$ (0.002)

Bond pad #1 (RF Input):	0,0940 x 0,0991 (0.0037 x 0.0039)
Bond pad #2 (RF Input):	0,0940 x 0,0991 (0.0037 x 0.0039)
Bond pad #3 (V_{CTRL}):	0,1016 x 0,1524 (0.0040 x 0.0060)
Bond pad #4 (V_D):	0,1321 x 0,2108 (0.0052 x 0.0083)
Bond pad #5 (V^+):	0,2032 x 0,1016 (0.0080 x 0.0040)
Bond pad #6 (RF Output):	0,0940 x 0,0991 (0.0037 x 0.0039)
Bond pad #7 (RF Output):	0,0940 x 0,0991 (0.0037 x 0.0039)
Bond pad #8 (V_{G1}):	0,0965 x 0,0965 (0.0038 x 0.0038)