

PowerPad™ CDMA/AMPS Cellular Band PA/Duplexer Module

Functional Block Diagram

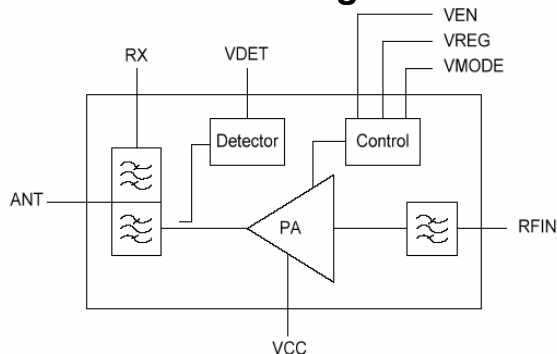

Product Description

TriQuint's TQM613017 is a fully matched PA/Duplexer, Front End Module (FEM) for CDMA/AMPS use in mobile phones. The 8 x 5 x 1.52 mm, 22-pin module includes an integrated SAW Duplexer, Power Amplifier, Transmit filter, RF Power Detector and Logic Controller. With an RF Power Output up to 25.5dBm the TQM613017 FEM meets the strict ACPR and ALTR requirements for products designed to the IS-95/98 standards. The quiescent current of the PA/Duplexer is set by the base-band processor using a 1-bit bias control (Vmode) to minimize battery consumption and maximize talk time.

TriQuint's multilayer laminate technology provides low loss interconnect and optimized match between the duplexer, PA and filter enabling the TQM613017 to achieve typically 430 mA current consumption at maximum output power (+25.5dBm). The small 8.0 x 5.0 mm module replaces four separate components requiring less board space. TQM613107 provides handset designers with a simple to use surface mount module requiring minimal external circuitry in the new generation of small and light phones.

Electrical Specifications

Parameter	Min	Typ	Max	Units
Frequency	824	836.5	849	MHz
CDMA Mode Pout ¹		+25.5		dBm
CDMA Mode ACPR (+/- 885kHz offset) ¹		-51		dBc
CDMA Mode ALTR (+/- 1.98 MHz offset) ¹		-59		dBc
CDMA Mode Current Consumption ¹		460		mA
CDMA Mode Leakage ¹		-30		dBm
ANT-to-Rx Insertion Loss		2.8		dB
Rx Noise		-181		dBm/Hz

Note 1: Test Conditions V_{CC}=3.4 V, V_{REF}=2.85 V, T=+25°C

Absolute Maximum Ratings¹

Data Sheet:

For additional information and latest specifications, see our website: www.triquint.com
Revision D, April 30, 2007

Features

- InGaP GaAs HBT PA
- Low Current Consumption
Typical: 460mA @ +25.5dBm
- Low Quiescent Current
Typical: 40mA
- 1-Bit Bias Control for Extended Talk Time
- Integrated power detector
- Integrated duplexer and interstage filter
- Excellent ACPR
Typical: -51 dBc @ +/- 885kHz offset
- Excellent ALTR
Typical: -60 dBc @ +/- 1.98 MHz offset
- Low Voltage Operation 1.3 V to 4.4 V
- Small Profile 22 pins, 8.0 x 5.0 x 1.52 mm
- Reduced Phone Board Space
Replaces 4 Separate Components
- Easy to use with few External Components
Internally matched inputs and outputs

Applications

- IS-95/CDMA2000
- Single-Mode, Dual Mode, and Tri Mode CDMA/AMPS phones

Package Style

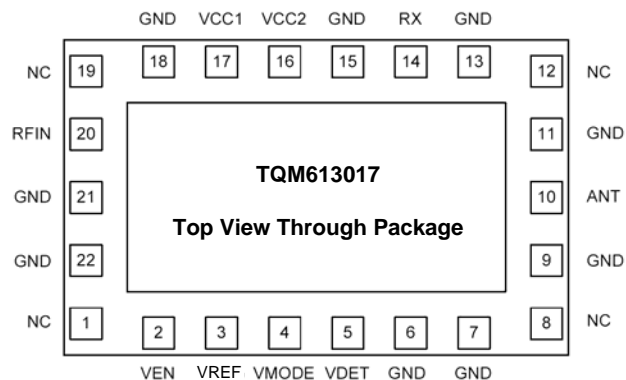

PowerPad™ CDMA/AMPS Cellular Band PA/Duplexer Module

Parameter	Symbol	Min.	Max.	Units
RF Input Power	P _{IN}	-	10.0	dBm
Supply Voltage	V _{CC}	-	6.0	Volts
Reference Voltage	V _{REF}	-0.5	3.5	Volts
Vmode (1 bit Bias Control)	V _{MODE}	-0.5	3.5	Volts
Venable	V _{EN}	-0.5	3.5	Volts
Case Operating Temperature	T _{CASE}	-30	+85	°C
Storage Temperature	T _{STORE}	-55	+125	°C
MSL		MSL-3, +260°C		

Note 1: The part may not survive all maximums applied simultaneously.

DC Electrical Characteristics

Parameter	Symbol	Min.	Typ/Nom	Max.	Units	
Supply Voltage	V _{CC}	P _{OUT} =13.5dBm to 25.5dBm	3.2	3.4	4.4	Volts
		P _{OUT} < 13.5dBm	1.3	3.4	4.4	Volts
Reference Voltage	V _{REF}	2.75	2.85	2.95	Volts	
	I _{REF_H} (V _{EN} =H)			15	mA	
	I _{REF_L} (V _{EN} =L)			1	mA	
Vmode (1 bit Bias Control)	V _{MODE_H}	High Bias Mode (High Power State)	0	-	0.5	Volts
		Low Bias Mode (Low Power State)	2.35	2.6	2.85	Volts
	I _{MODE}			1	mA	
Venable	V _{EN_H}	2.35	2.6	2.85	Volts	
	V _{EN_L}	0		0.5	Volts	
	I _{EN}			1	mA	
Case Operating Temperature	T _{CASE}	-30	25	+85	°C	

Power Range Truth Table

Power State	V _{Ref}	V _{mode}	V _{en}	Range
High Power	2.85 V	Low	High	+13.5 dBm to +25.5 dBm
Low Power	2.85 V	High	High	< +13.5 dBm
Shut Down	0 V	High or Low	Low	-

Note 1: Logic Low is 0 V to +0.5V, Logic High is +2.35 V to +2.85V

Data Sheet:

For additional information and latest specifications, see our website: www.triquint.com
 Revision D, April 30, 2007

PowerPad™ CDMA/AMPS Cellular Band PA/Duplexer Module

CDMA (IS-98C) Electrical Characteristics¹

Parameter	Conditions	Min.	Typ/Nom	Max.	Units
RF Frequency		824		849	MHz
Power Output					
Po_H	Vcc=3.4, 25°C<T<70°C, Vmode = Low	25.5			dBm
Po_HVT	Vcc=3.2 to 4.4V, -30°C>T>85°C, Vmode = Low	24.5			dBm
Po_M	Vcc=1.3 to 4.4V, -30°C>T>85°C, Vmode = High	13.5			dBm
Po_L	Vcc=1.3 to 4.4V, -30°C>T>85°C, Vmode = High			-52.5	dBm
Large Signal Gain					
G_H	Vcc=3.4V, 25°C, Vmode = Low, Po_H	20		28	dB
G_HVT	Vcc=3.2 to 4.4V, -30°C>T>85°C, Vmode = Low, Po_H	18		30	dB
G_M	Vcc=1.3 to 3.4, 25°C, Vmode = High, Po_M	11		28	dB
G_MVT	Vcc=1.3 to 4.4V, -30°C>T>85°C, Vmode = High, Po_M	9		28	dB
I _{AVERAGE}	Vcc=3.4V; Vref=2.85V; Temp=25°C, Vmode=2.85V Pout = Suburban Profile		75	90	mA
Gain Flatness					
GFLAT_H	Vcc=3.4V, T=25°C, Po_M to Po_H	-3		3	dB
GFLAT_L	Vcc=3.4V, T=25°C, Po_L to Po_M	-3		3	dB
Gain Sensitivity					
GSEN_V	Vcc=3.2 to 4.4V, 25°C	-1.25		1.25	dB
GSEN_T	Vcc=3.4V, -30°C>T>85°C	-3.0		3.0	dB
Quiescent Current (I _{CCO})	No RF Power		30	55	mA
Standby Current (I _{STBY})	-30°C<Temp<85°C, Vcc=4.4V, Vref=2.85V, Ven=0V			1	mA
Shut Down Current (I _{SDWN})	-30°C<Temp<85°C, Vcc=4.4V, Vref=0V, Ven=0V, Vmode=0V			30	uA
Adjacent Channel Power Ratio (ACPR)					
Offset = +/- 885kHz	Pout ≤ +25.5dBm, Vcc=3.4V, -30°C<Temp<70°C		-53	-45	dBc
	Pout ≤ +24.5dBm, Vcc=3.2V to 4.4V; -30°C<Temp<85°C		-51	-45	dBc
Alternate Channel Power Ratio (ALTR)					
Offset = +/-1.98 MHz	Pout ≤ +25.5dBm, Vcc=3.4V, -30°C<Temp<70°C		-64	-57	dBc
	Pout ≤ +24.5dBm, Vcc=3.2V to 4.4V; -30°C<Temp<85°C		-59	-57	dBc
VSWR	Tx Port		1.4:1	2.0:1	
Stability (all spurious)	Pout=25.5dBm, 10:1 VSWR, Pin=10dBm, All angles			-90	dBc

Data Sheet:

For additional information and latest specifications, see our website: www.triquint.com

Revision D, April 30, 2007

PowerPad™ CDMA/AMPS Cellular Band PA/Duplexer Module

Parameter	Conditions	Min.	Typ/Nom	Max.	Units
Ruggedness	Pout = +25.5dBm, 10:1 VSWR all phases; RX Port 5:1 VSWR all phases.	No damage/degradation			
Noise Power in Rx band at Rx terminal ²	Pout=+25.5dBm, 0°C<Temp<+70°C, 40dB noise source at CDMA input. F _{RX} =F _{TX} + 45MHz.		-181	-180	dBm/Hz
	Pout=+25.5dBm, 70°C<Temp<+85°C, 40dB noise source at CDMA input. F _{RX} =F _{TX} + 45MHz.			-178	dBm/Hz
Tx Leakage at Rx terminal	Pout= +25.5dBm; -25°C<Temp<70°C, Vcc=3.4V		-30	-26.8	dBm

Note 1: Test Conditions: V_{CC}=3.4V, V_{REF}=2.85V, T_C = +25°C, unless otherwise specified.

Note 2: Noise power is computed from a differential NF measurement of the Rx path while under CDMA Tx input RF drive with an added noise of 40dB above thermal noise floor.

AMPS Mode Electrical Characteristics¹

Parameter	Conditions	Min.	Typ/Nom	Max.	Units
RF Frequency		824		849	MHz
Power Output P _H	+25°C<T<+70°C	28			dBm
Large Signal Gain G _H G _{HVT}	Pout = 28dBm, Vcc=3.4V, 25C	20		28	dB
	Pout = 28dBm, Vcc=3.2 to 4.4V, -30°C>T>85°C	18		30	dB
PAE	Pout = 28dBm, Vcc=3.4V, 25°C		31		%

Note 1: Test Conditions: V_{CC}=3.4V, V_{REF}=2.85V, T_C = +25°C, unless otherwise specified.

Rx Characteristics

Parameter	Conditions	Min.	Typ/Nom	Max.	Units
Center Frequency	-30°C<Temp<85°C		881.5		MHz
Maximum Insertion loss	-30°C<Temp<85°C		2.8	4.0	dB
Absolute Attenuation ¹ 779-804 MHz 824-849 MHz 1039-1065 MHz 1050-1100 MHz 1200-1270 MHz 1648-1698 MHz 2472-2547 MHz	-30°C<Temp<85°C		35	-	dB
			50	-	dB
			42	-	dB
			42	-	dB
			50	-	dB
			55	-	dB
			25	-	dB
VSWR at Rx Terminal	-30°C<Temp<85°C		2.0:1	2.5:1	

Data Sheet:

For additional information and latest specifications, see our website: www.triquint.com
Revision D, April 30, 2007

PowerPad™ CDMA/AMPS Cellular Band PA/Duplexer Module

Power Detector Characteristics

Parameter	Conditions	Min.	Typ/Nom	Max.	Units
Range	Vcc=3.2 to 4.4V, -30°C<Temp<85°C	15		28.5	dBm
Detector Error (high power)					
Dem_H1	Pout=22dBm to 29dBm, VSWR=4.5:1, all phases, Vcc=3.2 to 4.4V, -30°C>T>85°C	-1.7		1.7	dB
Dem_H2	Pout=15dBm to 29dBm, VSWR=1.5:1, all phases, Vcc=3.2 to 4.4V, -30°C>T>85°C	-0.4		0.4	dB
Detector Error (low power)					
Dem_L1	Pout=5dBm to 15dBm, VSWR=4.5:1, all phases, Vcc=3.2 to 4.4V, -30°C>T>85°C	-2.5		2.5	dB
Dem_L2	Pout=5dBm to 15dBm, VSWR=4.5:1, all phases, Vcc=3.2 to 4.4V, -30°C>T>85°C	-1.5		1.5	dB
Variation in delivered power (D_PV)	Pout=22dBm to 29dBm, VSWR=3.5:1, all phases, Vcc=3.2-4.4V, -30°C>T>85°C	-3.5		1.0	dB
Detector Output Range (V_DR)	Pout=5dBm to 29dBm, Vcc=3.2 to 4.4V, -30°C>T>85°C	0.1		2.5	V
Detector voltage range @ 5dBm (V_DL)	Vcc=3.2 to 4.4V, -30°C>T>85°C	0.1			V
Detector voltage range @ 29dBm (V_DH)	Vcc=3.2 to 4.4V, -30°C>T>85°C	1.75		2.5	V
Detector output Impedance (off)	Vcc=3.2 to 4.4V, -30°C>T>85°C, Ven=Low	100			k-ohm
Detector Slope					
Sv_L	Pout=5dBm to 15dBm, VSWR=1.5:1, all phases, Vcc=3.2-4.4V, -30°C>T>85°C	8			mV/dB
Sv_H	Pout=15dBm to 29dBm, VSWR=1.5:1, all phases, Vcc=3.2-4.4V, -30°C>T>85°C		140		mV/dB
Detector time Response					
Tdon	Vcc=3.2 to 4.4V, -30°C>T>85°C			30	uS
Tdoff	Vcc=3.2 to 4.4V, -30°C>T>85°C			30	uS
Output ripple (Prpl)	Vcc=3.2 to 4.4V, -30°C>T>85°C	-0.3		0.3	dB

Data Sheet:

For additional information and latest specifications, see our website: www.triquint.com
Revision D, April 30, 2007

PowerPad™ CDMA/AMPS Cellular Band PA/Duplexer Module

Pin Out and Assignments

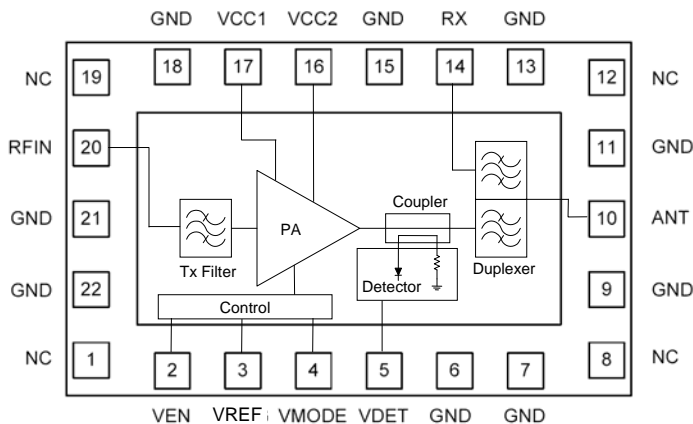

Pin	Symbol	Description
1	N/C	No Connection
2	V _{EN}	Enable/Disable
3	V _{REF}	Reference DC Supply (Regulated)
4	V _{MODE}	Digital Bias Mode Control Input
5	V _{DET}	Detector Voltage Output
6	GND	Ground
7	GND	Ground
8	N/C	No Connection
9	GND	Ground
10	ANT	Antenna Port ¹
11	GND	Ground
12	N/C	No Connection
13	GND	Ground
14	RX	Receiver Output Port ¹
15	GND	Ground
16	V _{CC2}	DC Supply (Battery)
17	V _{CC1}	DC Supply (Battery)
18	GND	Ground
19	N/C	No Connection
20	R _{FIN}	Transmit Input Port ¹
21	GND	Ground
22	GND	Ground

Note 1: DC Block included inside the module.

Data Sheet:

For additional information and latest specifications, see our website: www.triquint.com
Revision D, April 30, 2007

PowerPad™ CDMA/AMPS Cellular Band PA/Duplexer Module

Typical Test Circuit

TriQuint offers our customers the below evaluation board as a means for testing and analysis of 8 x 5mm PA/Duplexer. The evaluation board schematic and picture are provided for preliminary analysis and design. The resistors R1/R2 can be optimized to tradeoff the ACPR/Icc performance at medium/low power range.

Evaluation Board

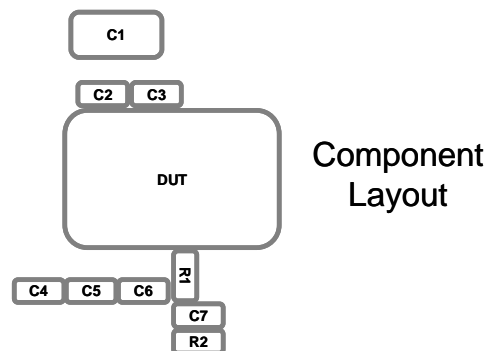
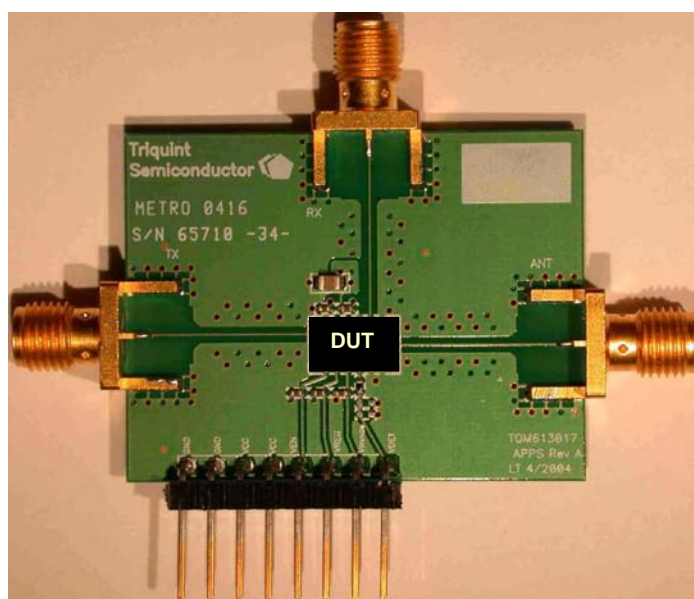

Single Row 8-position 0.1" Header Pins

VDET
VMODE
VREG
VEN
VCC
VCC
GND
GND

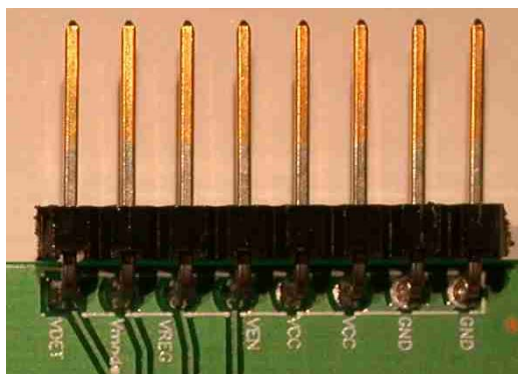

Signal	Description
GND	Common Ground
GND	Common Ground
VCC	DC Supply (Battery)
VCC	DC Supply (Battery)
VEN	Module Enable/Disable (Digital)
VREG	DC Supply (Regulated)
VMODE	Bias Mode Control (Digital)
VDET	Detector Voltage

Note: Both GND terminals and VCC terminals are tied together on the apps PCB.

Data Sheet:

For additional information and latest specifications, see our website: www.triquint.com
Revision D, April 30, 2007

PowerPad™ CDMA/AMPS Cellular Band PA/Duplexer Module

Evaluation Board and Typical Phoneboard Schematic

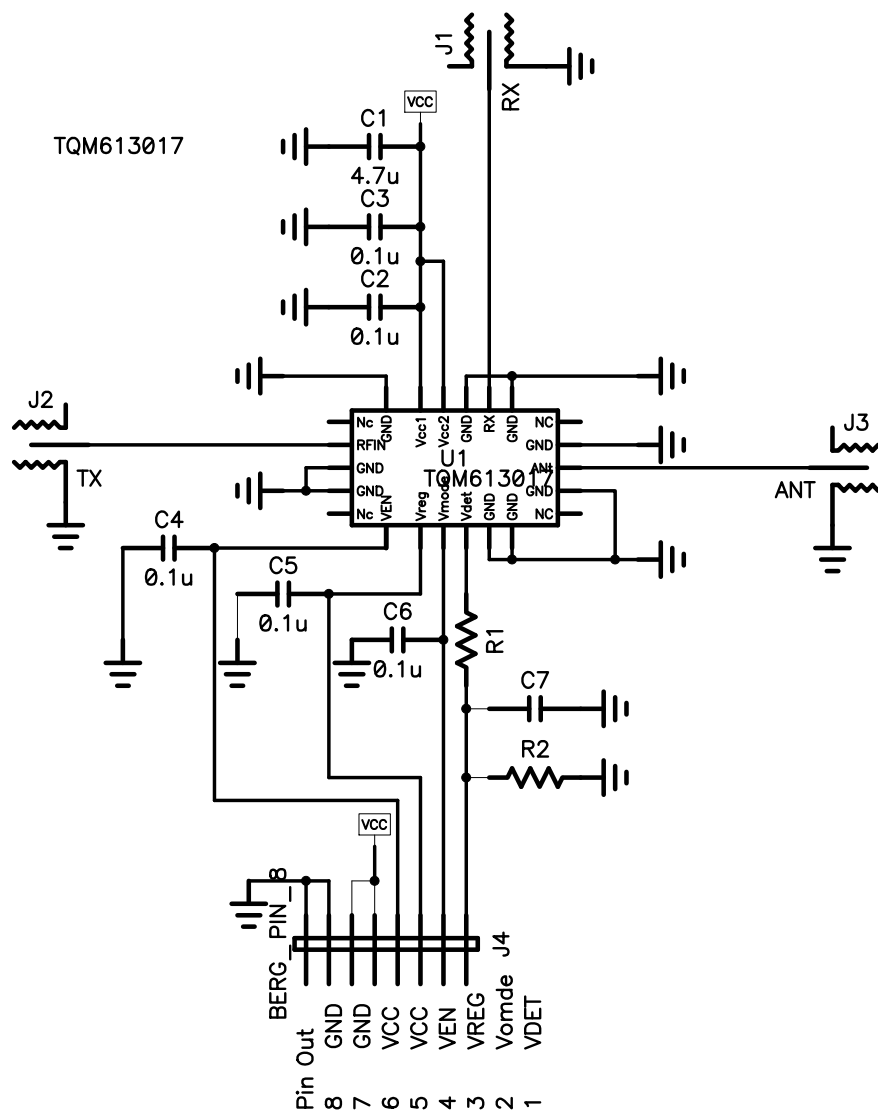

Data Sheet:

For additional information and latest specifications, see our website: www.triquint.com
Revision D, April 30, 2007

PowerPad™ CDMA/AMPS Cellular Band PA/Duplexer Module

Applications Information: Power Up/Down Sequences

Power-Up Sequence

SEQUENCE	PIN	DESCRIPTION
1	V_{CC}	Apply Battery Voltage
2	V_{REF}	Apply Reference Voltage
3	V_{MODE}	Set Bias Mode
4	V_{EN}	Enable PA
5	RF	Apply RF

Power-Down Sequence

SEQUENCE	PIN	DESCRIPTION
1	RF	Remove RF
2	V_{EN}	Disable PA
3	V_{MODE}	Set Bias Mode to 0V
4	V_{REF}	Remove Reference Voltage
5	V_{CC}	Remove Battery Voltage

Data Sheet:

For additional information and latest specifications, see our website: www.triquint.com
Revision D, April 30, 2007

PowerPad™ CDMA/AMPS Cellular Band PA/Duplexer Module

PC Board Layout Recommendations

TOP VIEW ETCH RECOMMENDATIONS

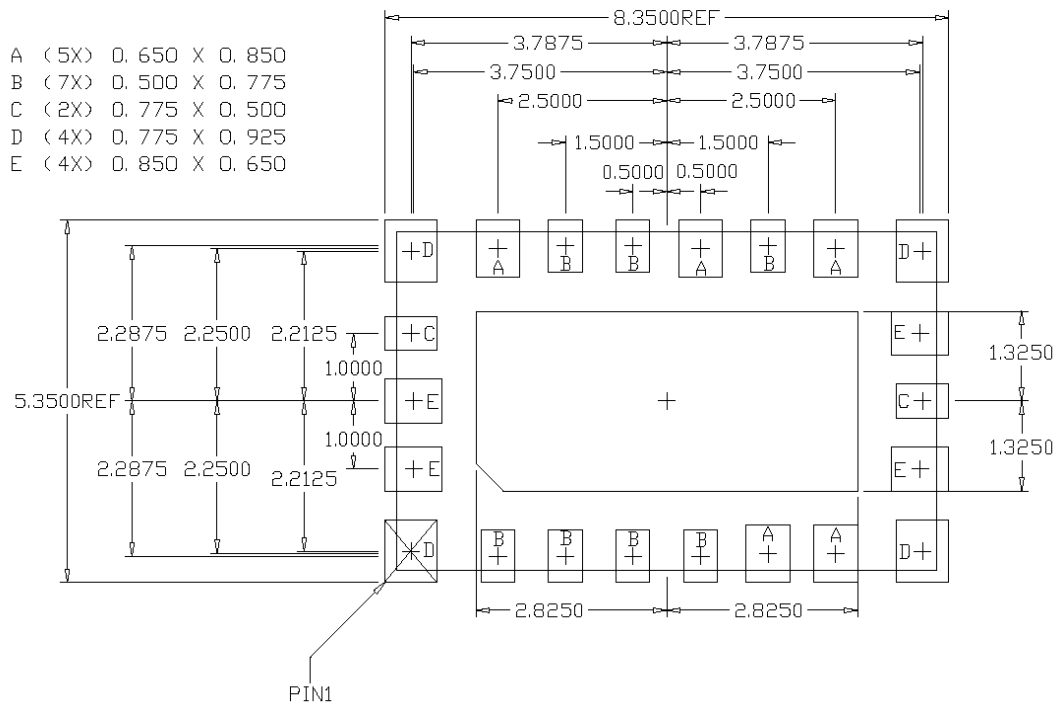

TOP VIEW SOLDERMASK RECOMMENDATIONS
OVERSIZE MASK 6MIL

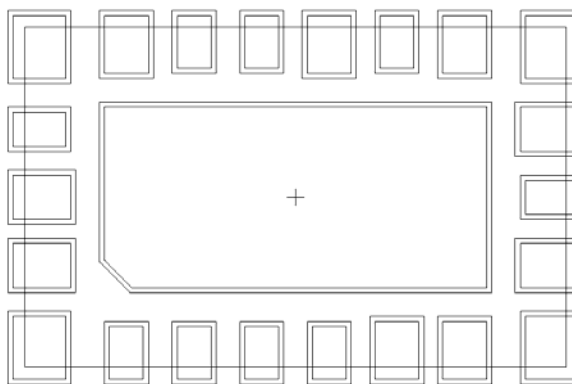

PowerPad™ CDMA/AMPS Cellular Band PA/Duplexer Module

Recommended Reflow Profile

The TQM613017 is rated for 260°C reflow profile. Below is a general recommendation for 260°C reflow. The specific profile used will need to take into account the requirements of the board used, other components used, and the specific layout of the components. The following recommendation should be used as a guideline only.

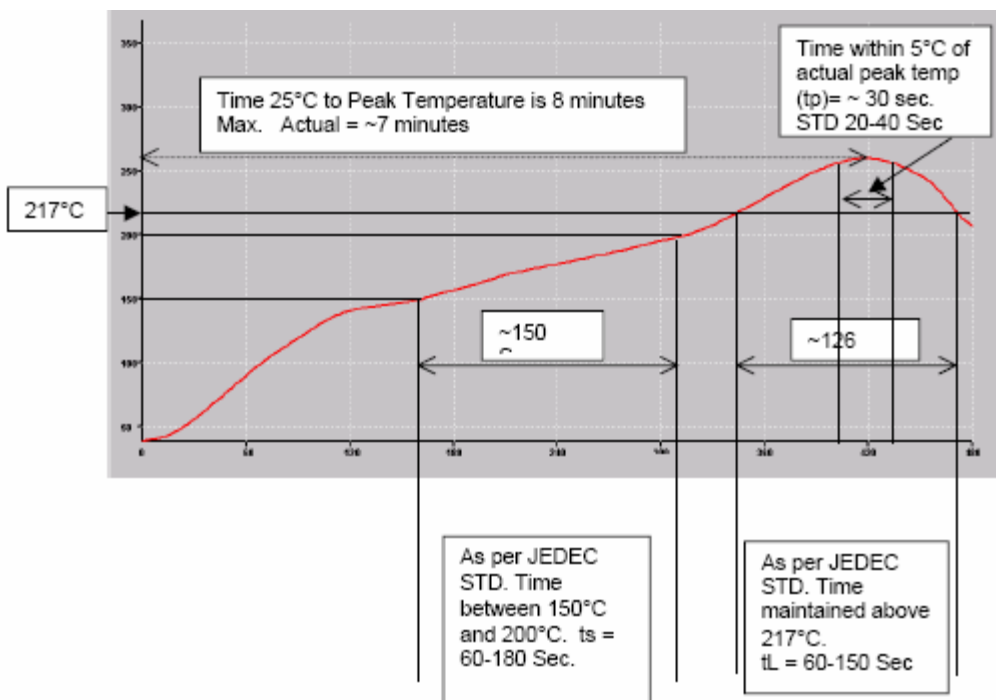

PowerPad™ CDMA/AMPS Cellular Band PA/Duplexer Module

Packaging and Ordering Information

Package Dimensions:

TOP VIEW

SIDE VIEW

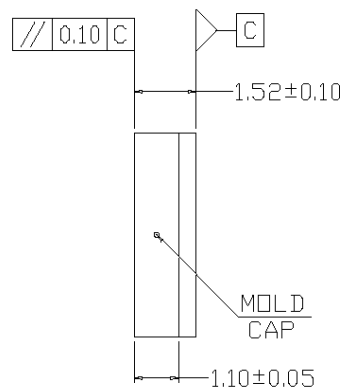
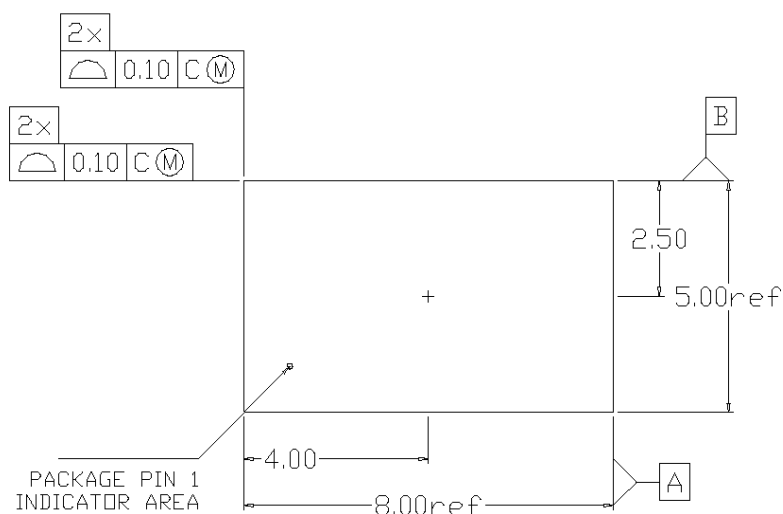

BOTTOM VIEW

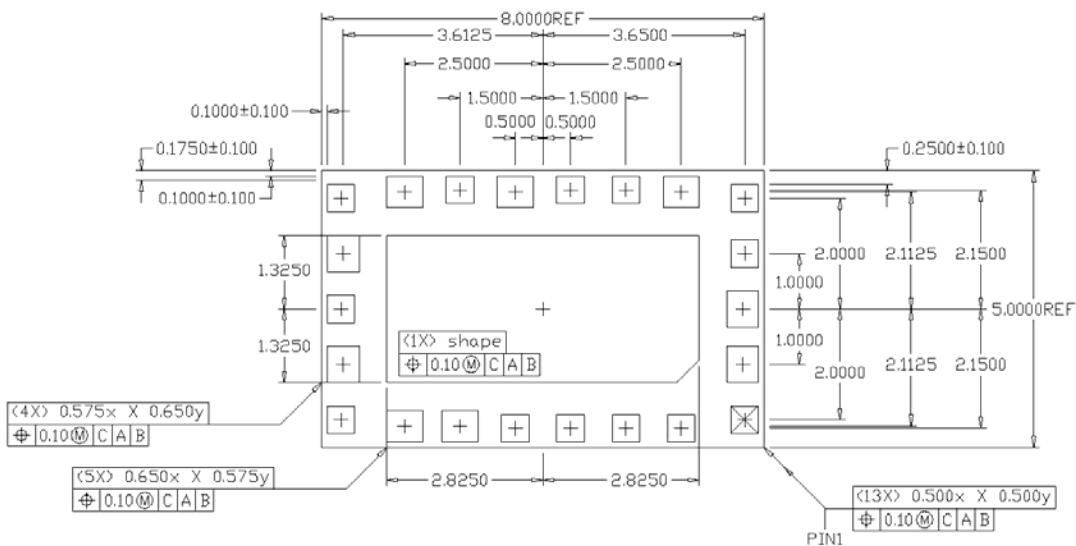

PowerPad™ CDMA/AMPS Cellular Band PA/Duplexer Module

Package Dimensions:

TOP VIEW LOOKING THROUGH MODULE

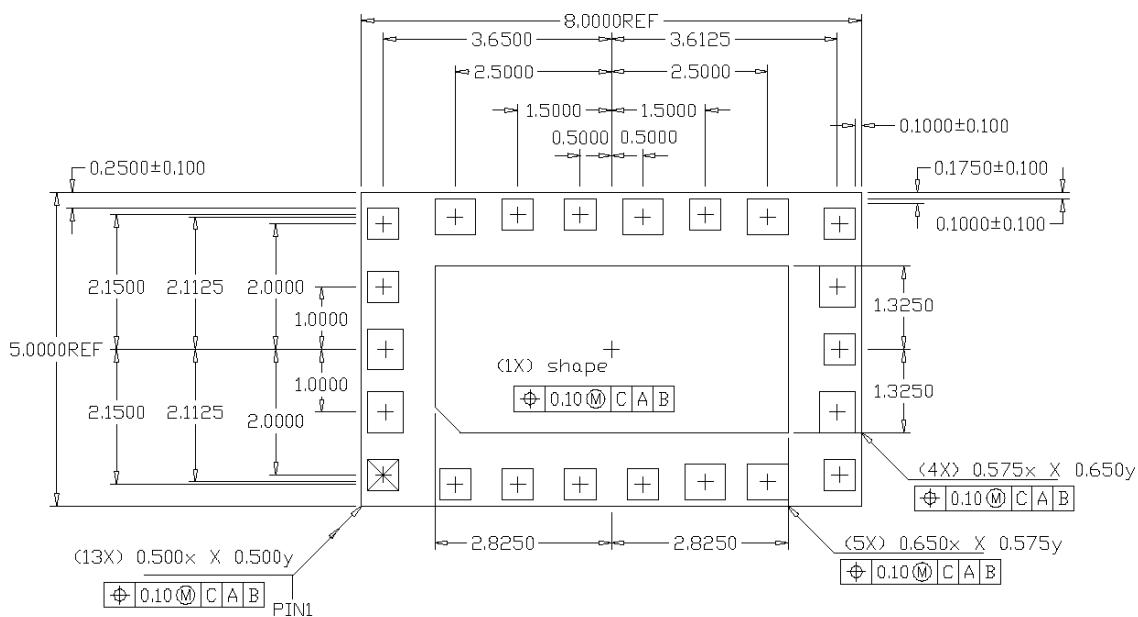

Package Marking:

TOP MARK



- 1) Line 1: Product code = TQM613017
- 2) Line 2: Country Code = CCCC (USA = United States, PHIL = Philippines)
- 3) Line 3: AaXXXX-Z = Aa = Vendor code + XXXX = TriQuint Lot Number + Z = Sub lot # (1, 2, 3, ...)
- 4) Line 4: YYWW = Year and Work Week

PowerPad™ CDMA/AMPS Cellular Band PA/Duplexer Module

Tape and Reel Specification:

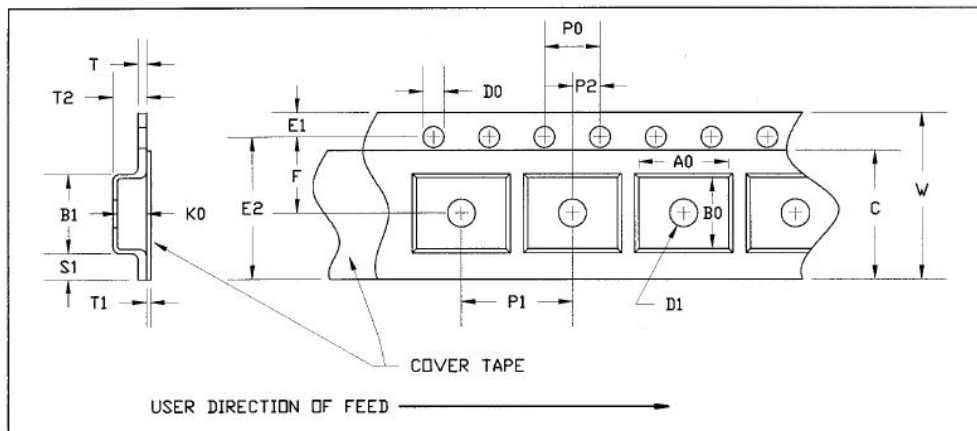

FIXED CARRIER AND COVER TAPE DIMENSIONS

PART	FEATURE	SYMBOL	SIZE (in)	SIZE (mm)
CAVITY	BOTTOM HOLE DIAMETER	D1	0.059	1.50
PERFORATION	DIAMETER	D0	0.059	1.50
	PITCH	P0	0.157	4.00
	POSITION	E1	0.069	1.75
CARRIER TAPE	THICKNESS	T	0.012	0.30
COVER TAPE	THICKNESS	T1	0.002	0.056

MODULE – 5x8 CARRIER AND COVER TAPE DIMENSIONS

PART	FEATURE	SYMBOL	SIZE (in)	SIZE (mm)
CAVITY	LENGTH	A0	0.217	5.50
	WIDTH	B0	0.335	8.5
	DEPTH	K0	0.079	2.0
	PITCH	P1	0.472	12.00
DISTANCE BETWEEN CENTERLINE	CAVITY TO PERFORATION LENGTH DIRECTION	P2	0.079	2.00
	CAVITY TO PERFORATION WIDTH DIRECTION	F	0.295	7.50
COVER TAPE	WIDTH	C	0.524	13.30
CARRIER TAPE	WIDTH	W	0.630	16.00

PowerPad™ CDMA/AMPS Cellular Band PA/Duplexer Module

Tape and Reel Specification:

User Direction of Feed →

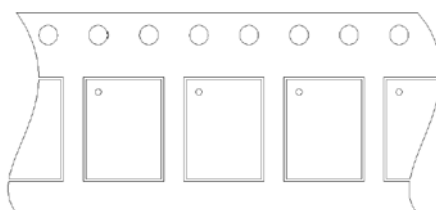

MODULE 5x8

User Direction of Feed →

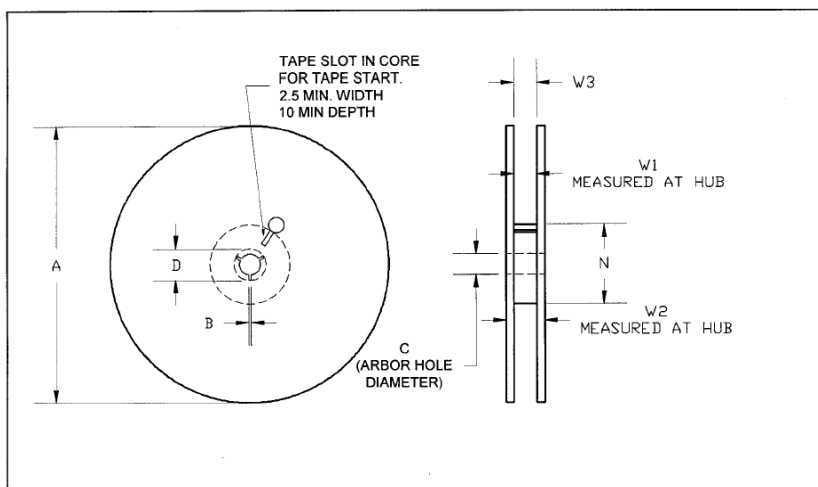

Reel Dimensions for 16mm Carrier Tape

SOIC-14, SOIC-16 BATWING, QSOP 24, SSOP-24, TSSOP-20 & 28 HP VFQFP-N 7x7 and SOT 223. Modules 5X8, 5X9, 6X6, 7X7, 8X8, 7X10 and 9.55X8.75			13" REEL	
PART	FEATURE	SYMBOL	SIZE (in)	SIZE (mm)
FLANGE	DIAMETER	A	12.992	330.0
	THICKNESS	W2	0.874	22.2
	SPACE BETWEEN FLANGE	W1	0.661	16.8
HUB	OUTER DIAMETER	N	4.016	102.0
	ARBOR HOLE DIAMETER	C	0.512	13.0
	KEY SLIT WIDTH	B	0.079	2.0
	KEY SLIT DIAMETER	D	0.787	20.0

PowerPad™ CDMA/AMPS Cellular Band PA/Duplexer Module

Shipment Box & Label Description:

Tape & Reels will be packaged in a drypack bag and then in a shipment box. The box dimensions will depend on the number of reels shipped in each box and are noted in the table below. The box label and a description of each item on the label is also shown below.

13 Inch x16mm--Drypack		
Box Size	Reel Qty/Box	Empty Box Wt w/ Packing
15x15x7	3	2
18x15x11	5	2.36
17x16x17	9	2.76



Format: 4 * 6.5 in 102 * 166 mm Code 39 1:2	Ship From: TRIQUINT SEMICONDUCTOR, INC 2300 NE BROOKWOOD PARKWAY HILLSBORO, OR 97124	Ship To: Recipient Address Information Here
Supplier Code: 10 Character Max. + TQS Shipper Number. (Pkg. ID/Serial Number)	(3S) Pkg ID: 581+23047123 	
Customer Purchase Order. 20 Character Max.	(K) Trans ID: 812934657 	
Customer Part Number. 22 Character Max.	(P) CPN: 5871-2489 	
Quantity.	(Q) QTY: 20000 	
Supplier Product Number. 21 Character Max.	(1P) SPN: TQD777001 	
Box Count (1/3, 2/3, etc.)	(13Q) Pkg Count: 1/1 	
	Package Weight 3.0 LB / 1.36 KG	

All Barcodes Contain Data Identifier Followed by Data, e.g. K812934657

Manufacturer's Part Number → **MPN: 1005859**

PowerPad™ CDMA/AMPS Cellular Band PA/Duplexer Module

Lead-free statement:

All new TriQuint products/packages introduced since June, 2003 are qualified using RoHS compliant Pb-free plating. Labels on the tape reel and the shipping carton will include the lead free logo.



TQM613017 5 x 8 mm package has gold (Au) plated contacts.

Additional Information¹

This product is compliant with RoHS material restrictions and is rated MSL level 3 per JEDEC standard IPC/JEDEC J-STD-020.

¹ For latest specifications, additional product information, worldwide sales and distribution locations, and information about TriQuint:

Web: www.triquint.com

Tel: (503) 615-9000

Email: info_wireless@tqs.com

Fax: (503) 615-8902

For technical questions and additional information on specific applications:

Email: info_wireless@tqs.com

The information provided herein is believed to be reliable; TriQuint assumes no liability for inaccuracies or omissions. TriQuint assumes no responsibility for the use of this information, and all such information shall be entirely at the user's own risk. Prices and specifications are subject to change without notice. No patent rights or licenses to any of the circuits described herein are implied or granted to any third party.

TriQuint does not authorize or warrant any TriQuint product for use in life-support devices and/or systems.

Copyright © 2004-5 TriQuint Semiconductor, Inc. All rights reserved.