

CDMA Cellular Band PA/Duplexer Module

Functional Block Diagram

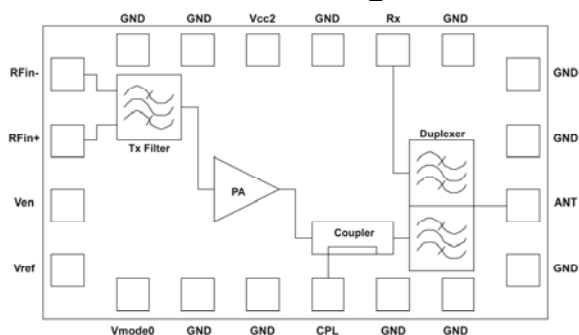

Product Description

TriQuint's TQM613025 is a fully matched CDMA cellular band PA/Duplexer (PAD) module for use in mobile phones. The 7.0 x 4.0 x 1.2 mm, 20-pin module includes a SAW Duplexer, Power Amplifier, Differential input transmit filter, RF Power Coupler and Logic Controller. With an RF Power Output up to 25.5dBm the TQM613025 PAD meets the strict ACPR and ALTR requirements for products designed to the CDMA IS-95/98/2000 standards. It's thin form factor and compact size, coupled with the low quiescent current, makes the TQM613025 ideal for today's compact feature rich multi-media handsets requiring longer battery life.

TriQuint's multilayer laminate technology provides low loss interconnect and optimized match between the duplexer, PA and filter enabling the TQM613025 to achieve only 40 mA of typical current consumption at maximum output power in low power mode (+13.5dBm). The small 7.0 x 4.0 mm module replaces four separate components and matching requiring less board space. TQM613025 provides handset designers with a simple to use surface mount module requiring minimal external circuitry for faster time to market and reduced BOM count.

Electrical Specifications

Test Conditions $V_{CC}=3.4V$, $V_{REF}=-2.85V$, $T=+25^{\circ}C$

Parameter	Min	Typ	Max	Units
Frequency	824.7	836.5	848.3	MHz
Pout		+25.5		dBm
ACPR (+/- 885kHz offset)		-50		dBc
ALTR (+/- 1.98 MHz offset)		-60		dBc
Current Consumption @ +25.5 dBm		430		mA
Current Consumption @ +13.5 dBm		40		mA
Quiescent Current		18		mA
Leakage at Rx Port		-31		dBm
ANT-to-Rx Insertion Loss		2.6	3.5	dB
Rx Noise		-182		dBm/Hz

Features

- InGaP GaAs HBT PA with high efficiency at low power architecture
- Low Quiescent Current
Typical: 18 mA
- Low Current Consumption
Typical: 430 mA @ +25.5dBm
Typical: 415 mA @ +24.5dBm
Typical: 40 mA @ +13.5dBm
- Excellent ACPR
Typical: -50 dBc @ +/- 885kHz offset
- Excellent ALTR
Typical: -60 dBc @ +/- 1.98 MHz offset
- Lead-free 260°C RoHS Compliant
- Small 20-pin, 7.0x4.0mm module with matching replacing ~10 discrete components
- Typical height of 1.2mm for thin phones
- Integrated duplexer, coupler, differential input transmit filter and matching
- Optimized for use with Qualcomm's QSC6010/20/30™ single chip devices

Applications

- IS-95/98/CDMA2000
- Single-band CDMA Cellular radios

Package Style

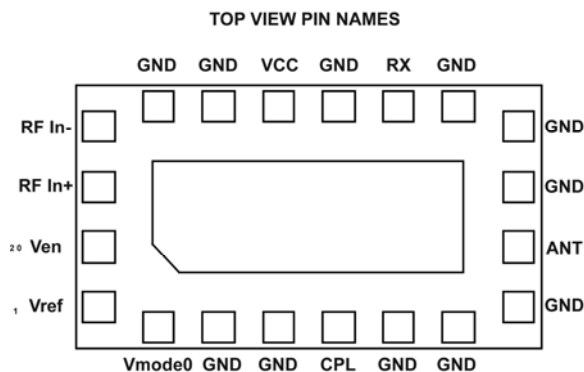

Data Sheet

For additional information and latest specifications, see our website: www.triquint.com
Revision J, September 18, 2007

CDMA Cellular Band PA/Duplexer Module

Absolute Maximum Ratings¹

Parameter	Symbol	Min Rating	Max Rating	Unit
Supply voltage	Vcc	-	+6.0	V
Reference Voltage	Vref	-0.5	+3.0	V
Control voltages	Ven, Vmode	-0.5	+3.0	V
Input RF power	Tx port	-	+10	dBm
	Antenna port	-	+30	dBm
	Rx port	-	+10	dBm
Case Operating Temperature	Tcase	-30	+85	°C
Storage temperature	Tstore	-30	+150	°C
MSL		MSL-3, +260°C		

Note 1: Stresses above those listed under absolute maximum ratings may cause permanent and functional damage to the device. Exposure exceeding absolute maximum rating conditions for extended periods may affect device reliability.

DC Electrical Characteristics

Parameter	Condition	Symbol	Min	Typ	Max	Unit
Supply Voltage	High / low power	Vcc	3.20		4.25	V
Reference Voltage	-	Vreg	2.79		2.91	V
Enable Digital Control Voltage	Low	Ven	0.00		0.50	V
	High	Ven	2.15		2.75	V
Enable Digital Control Current	-	Ien			1	mA
1 bit Bias Control Current	Low	Vmode	0.00		0.50	V
	High	Vmode	2.15		2.75	V
1 bit Bias Control Current	Current	Imode			1	mA
Operating Current High Power Mode	Pout=+25.5dBm, T=+25°C, Vcc=3.4V	Icc_high		430		mA
Operating Current Low Power Mode	Pout=+13.5dBm, T=+25°C, Vcc=3.4V	Icc_low		40		mA
Quiescent Current	Low Power Mode	Icq		18		mA
Iref Current	Ven=high	Iref			5	mA
	Ven=low	Iref			1	mA

Data Sheet

For additional information and latest specifications, see our website: www.triquint.com
 Revision J, September 18, 2007

CDMA Cellular Band PA/Duplexer Module

DC Electrical Characteristics (Continued)

Parameter	Condition	Symbol	Min	Typ	Max	Unit
Leakage Current	V _{cc} =high, enable=low, V _{mode} =0=X	I _{leak}			10	μA
Turn on/off time ¹	DC: I _{cc}	T _{on-DC} , T _{off-DC}			20	μS
	RF: P _{out}	T _{on-RF} , T _{off-RF}			6	μS
Gain Switching Time	High-low	t _{mode}			10	μS
Ambient Operating Temperature		TEMP _{op}	-30		+85	°C
Case Temperature	Ambient operating temp not exceeded	TEMP _{case}	-20		TBD	°C
Power Supply Noise Rejection		P _{nr}			TBD	

1. *Definition of switching time:*

T_{ON-DC} ≡ The time required to obtain the idle bias condition ±10% from a zero bias condition with RF signal applied.

T_{ON-RF} ≡ The time required to go from zero output power to reach the final output power ± 1 dB.

T_{OFF-RF} ≡ The time required for the output power to decrease 30 dB when input signal is removed.

T_{OFF-DC} ≡ The time required for the bias current (idle current) to decrease to < 100 μA.

Power Range Truth Table

Mode of operation	V _{en}	V _{MODE}	V _{CC}
Power down	LOW	LOW	ON
Stand-by mode	LOW	X	ON
High power mode (13.5 dBm ≤ P _{OUT} ≤ 25.5 dBm)	HI	LOW	ON
Low power mode (-50 dBm ≤ P _{OUT} ≤ 13.5 dBm)	HI	HIGH	ON

Note 1: Logic Low is 0 V to +0.5V, Logic High is +2.35 V to +2.85V

Data Sheet

For additional information and latest specifications, see our website: www.triquint.com

Revision J, September 18, 2007

CDMA Cellular Band PA/Duplexer Module

RF Electrical Characteristics

Tx to Antenna Port Parameters					
Parameter	Condition	Min	Typ	Max	Unit
Frequency	-30°C<T<+85°C	824.7		848.3	MHz
Maximum Output Power	Vcc=3.2-4.25V; -30C<T<85C; Vref=2.85V	24.5			dBm
	Vcc=3.4V; T=25C, Vref = 2.85V	25.5			dBm
Gain in Tx band	Pout=24.5dBm, Vcc=3.4V;836.5MHz ;T=25C ; Vref=2.85V	19	22	25	dB
	Pout≤13.5dBm, Vcc=3.4V ; T=25C ; Vref=2.85V	10	12.5	15	dB
Gain Flatness Tx band	13.5dBm<Pout≤24.5dBm Vcc=3.4V; -30C<T<85C ; Vref=2.85V	-1.5		1.5	dB
	-50dBm<Pout≤13.5dBm Vcc=3.4V; -30C<T<85C ; Vref=2.85V	-1.5		1.5	dB
Gain Sensitivity	Vcc=3.2V to 4.25V; T=25C; Vref=2.85V	-1.25		1.25	dB
	Vcc=3.4V; -30C<T<85C; Vref=2.85V	-2.5	-	2	dB
Impedance	Tx Port		200		Ohms
	Antenna Port		50	2:1	Ohms
	Rx Port		50	2:1	Ohms
Amplitude imbalance	Tx Port		0	±1	dB
Phase imbalance	Tx Port		2	±8	Deg
Adjacent Channel Power (ACP)	Vcc=3.4V; -30C<T<70C; Pout ≤ 25.5 dBm Vref=2.85V		-50	-45	dBc
Offset = +/- 885kHz	Vcc=3.4V; -30C<T<85C; Pout ≤ 24.5 dBm Vref=2.85V		-56	-45	dBc
Alternate Channel Power (ALT)	Vcc=3.4V; -30C<T<70C; Pout ≤ 25.5 dBm Vref=2.85V		-60	-56	dBc
Offset = +/- 1.98MHz	Vcc=3.4V; -30C<T<85C; Pout ≤ 24.5 dBm Vref=2.85V		-62	-56	dBc
Stability, Spurious	VSWR ≤8:1 @ all phases in Tx Band Pout=25.5dBm; Pin=10dBm			-65	dBc
Ruggedness	VSWR ≤20:1 @ all phases Pout=25.5dBm; Pin=10dBm	No damage No degradation			-

Data Sheet

For additional information and latest specifications, see our website: www.triquint.com
 Revision J, September 18, 2007

CDMA Cellular Band PA/Duplexer Module

RF Electrical Characteristics (Continued)

Tx to Antenna Port Parameters					
Parameter	Condition	Min	Typ	Max	Unit
Attenuation	0 - 800 MHz	20	30		dB
Rx	869 - 894 MHz	45	50		dB
GPS	1570 - 1580 MHz	50	60		dB
2fo	1638 - 1708 MHz	50	60		dB
PCS Rx	1930 - 1990 MHz	45	55		dB
3fo	2462 - 2557 MHz	50	60		dB
Harmonics, 2fo, 3fo	Pout<24.5dBm		-55	-30	dBc
GPS Noise Power in GPS Band at ANT terminal ¹	T=25C		-183	-180	dBm/Hz

1. Assumes =130dBm/Hz @ 1575.42 MHz injected at input to the Transmit port.

Antenna to Rx Port Parameters					
Parameter	Condition	Min	Typ	Max	Units
Frequency	-30C<T<85C	869		894	MHz
Insertion Loss	-30C<T<85C		2.6	3.5	dB
Return Loss	-30C<T<85C	8	12		dB
Attenuation	0 - 800 MHz	20	27		dB
Attenuation: Transmit	824 - 849 MHz	47	52		dB
Attenuation: GPS	1570 - 1580 MHz	50	55		dB
Attenuation: PCS & IMT Bands	1850 - 2170 MHz	35			dB
Attenuation: 3LO & ISM Band	2400 - 2600 MHz	35	47		dB

Data Sheet

For additional information and latest specifications, see our website: www.triquint.com
Revision J, September 18, 2007

CDMA Cellular Band PA/Duplexer Module

RF Electrical Characteristics (Continued)

Tx to Rx Port Parameters					
Parameter	Condition	Min	Typ	Max	Units
Noise Power in Rx Band at Rx terminal ^{1,2}	Pout=24.5dBm; Vcc=3.4V T=25C, 44dB noise input		-182		dBm/Hz
	Pout=24.5dBm; Vcc=3.4V, 25C<T<85C, 44dB noise input			-176	dBm/Hz
Tx Leakage at Rx terminal ²	Pout=24.5dBm; Vcc=3.4V -30C<T<85C, VSWR=2:1		-31	-28.5	dBm

- Assumes -130 dBm/Hz Rx band noise injected at input to the Tx port. Noise power is computed from a differential NF measurement of the Rx path while under CDMA Tx Input RF drive with an added noise of 44dB above thermal noise floor.
- Antenna port terminated into a 2:1 VSWR.

Coupled Port Parameters					
Parameter	Condition	Min	Typ	Max	Units
Power at detector port	Relative to ANT port		-19.5		dB
Isolation	Antenna to Detector Port		40		dB
Directivity			20		dB

Data Sheet

For additional information and latest specifications, see our website: www.triquint.com
Revision J, September 18, 2007

CDMA Cellular Band PA/Duplexer Module

Evaluation Board

TriQuint offers our customers the below evaluation board as a means for testing and analysis of the TQM613025. The evaluation board schematic and picture are provided for preliminary analysis and design. Figure 2 shows the TriQuint application board while Figure 3 shows the schematic of the board followed by the power-up/power-down sequence instructions.

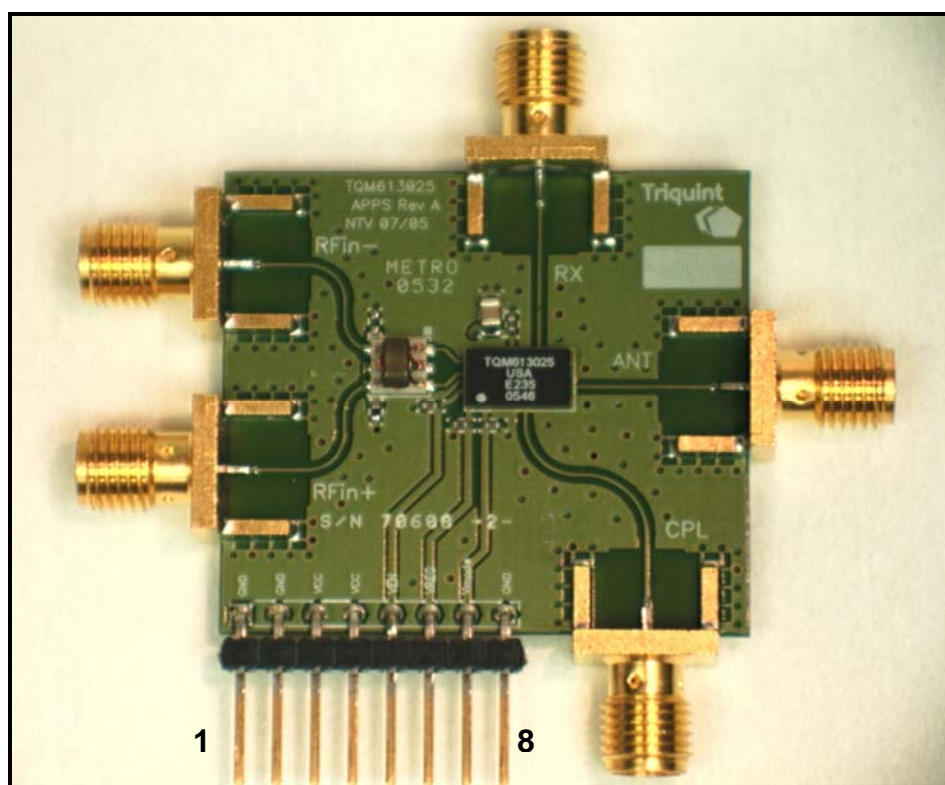

Pin #	Function	Pin #	Function
1	GND	5	VEN, enable digital control
2	GND	6	VREF, reference voltage
3	VCC	7	Vmode, High/low bias mode
4	VCC	8	GND

Figure 2: Evaluation Board Picture and Pin Definition Table

Data Sheet

For additional information and latest specifications, see our website: www.triquint.com
Revision J, September 18, 2007

CDMA Cellular Band PA/Duplexer Module

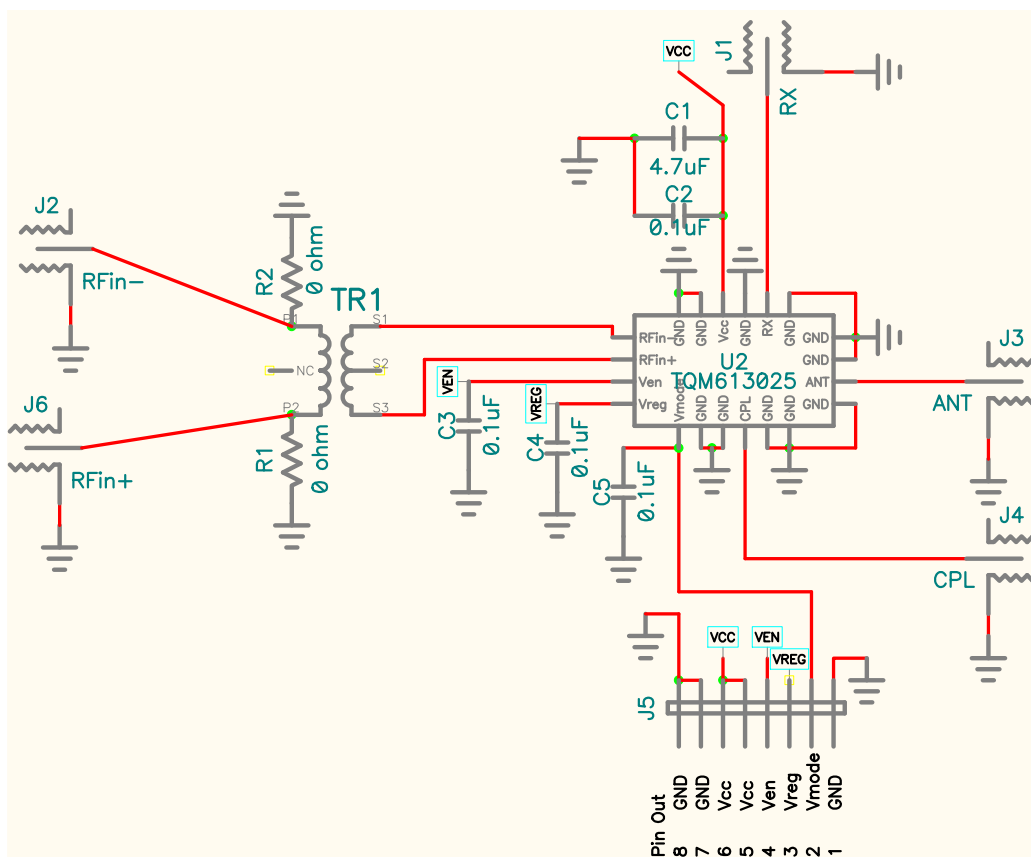

Figure 3: Evaluation Board Schematic

Note: R1 & R2 are optional resistors, not placed if RFin+ and RFin- connectors are used. J6 is optional connector if single-ended input is required.

Applications Information: Power Up/Down Sequences

Power-Up Sequence			Power-Down Sequence		
Sequence	PIN	Description	Sequence	PIN	Description
1	VCC	Apply Battery Voltage	1	RF	Remove RF
2	VREF	Apply Reference Voltage	2	VEN	Disable PA
3	Vmode	Set Bias Mode	3	Vmode	Set Bias Mode to 0V
4	VEN	Enable PA	4	VREF	Remove Reference Voltage
5	RF	Apply RF	5	VCC	Remove Battery Voltage

Data Sheet

For additional information and latest specifications, see our website: www.triquint.com
Revision J, September 18, 2007

CDMA Cellular Band PA/Duplexer Module

Packaging Characteristics

Package Pin Assignments

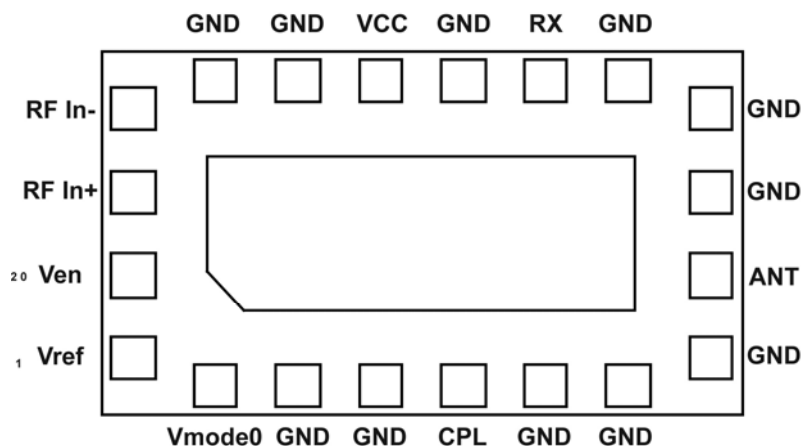

**Figure 4: Package Pin-Out Identification Drawing
Top View (X-ray)**

Note: DC Block included inside the module

Pin #	Description	Function
1	VREF	Reference Voltage
2	Vmode	High/Medium Power Mode selection
3	GND	Ground
4	GND	Ground
5	CPL	Coupler Output
6	GND	Ground
7	GND	Ground
8	GND	Ground
9	ANT	Antenna Port
10	GND	Ground
11	GND	Ground
12	GND	Ground
13	RX	Receiver output port from Duplexer
14	GND	Ground
15	VCC	Power Supply
16	GND	Ground
17	GND	Ground
18	RFin-	Tx Differential Input (-)
19	RFin+	Tx Differential Input (+)
20	VEN	Enable Voltage input

CDMA Cellular Band PA/Duplexer Module

PC Board Layout Recommendations

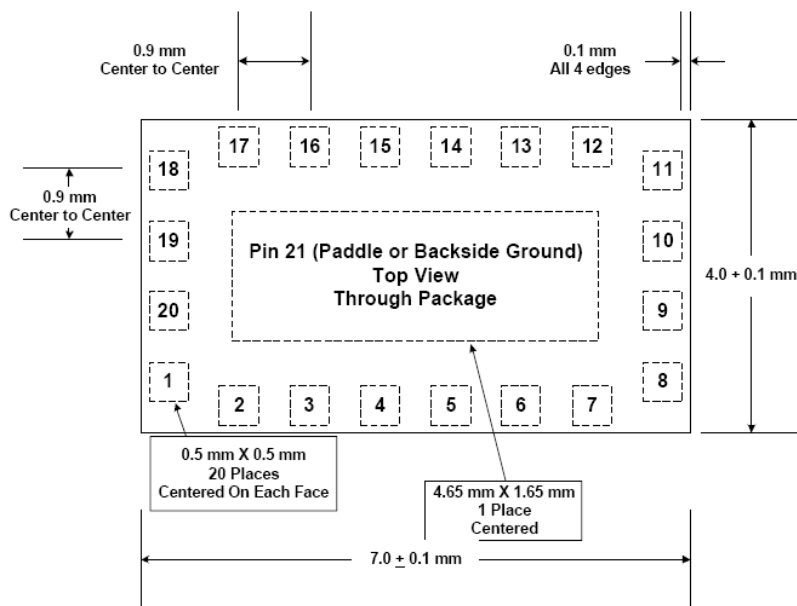
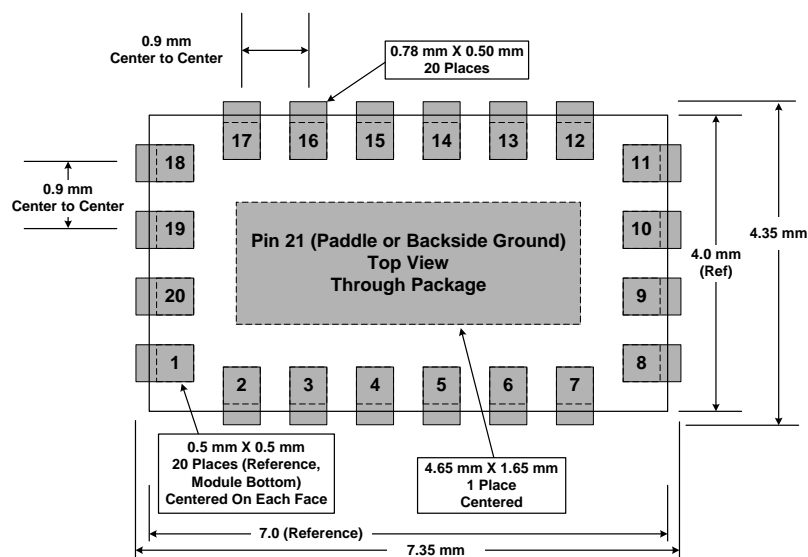

Figure 5: 7x4mm Module Package Drawing for Footprint Design



- Notes:
1. This drawing shows the recommended pin sizes and locations for mounting the module on a customer board.
 2. Pins that are "No Connect" or that net to ground may be buried in any surface copper pour used for ground plane. TriQuint does not recommend any thermal relief for surface ground pins. These pins should be buried in the surface copper.

Figure 6: Recommended Copper Footprint for 7x4mm Module

CDMA Cellular Band PA/Duplexer Module

PC Board Layout Recommendations (continued)

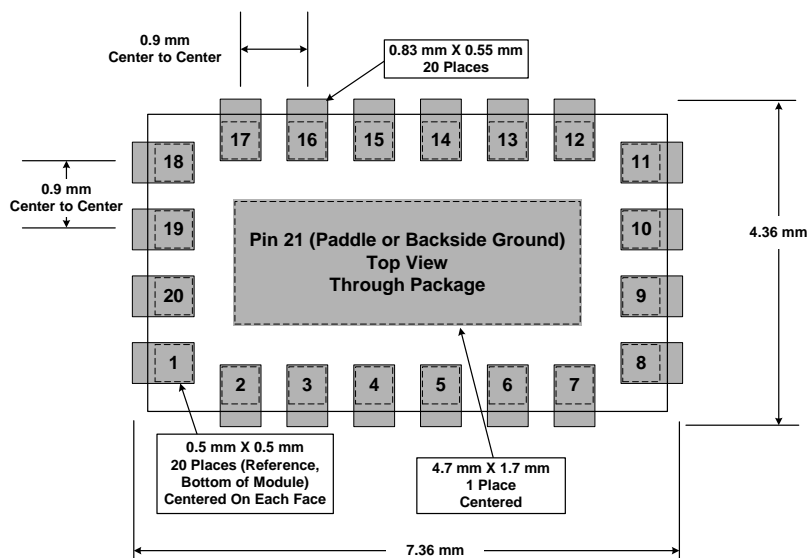

Notes:
 1. This drawing is a negative image. Colored areas indicate the absence of solder mask material.
 2. Dimensions reflect a solder mask swell of 0.05 mm. Depending on the board vendor's tolerances, this dimension might need to grow to a solder mask swell of 0.1 mm. Check with your vendor and quality departments.

Figure 7: Solder Mask Layout for 7x4mm Module Package

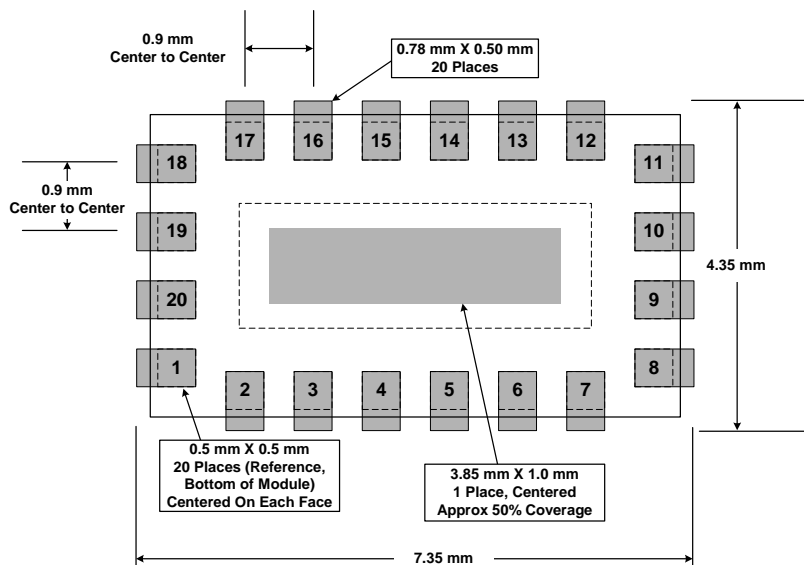

Note: This drawing is a negative image. Colored areas indicate the openings in solder stencil material.

Figure 8: Solder Stencil Option for 7x4mm Module

CDMA Cellular Band PA/Duplexer Module

Recommended Reflow Profile

The TQM613025 is rated for 260°C reflow profile. Below is a general recommendation for 260°C reflow. The specific profile used will need to take into account the requirements of the board used, other components used, and the specific layout of the components. The following recommendation should be used as a guideline only.

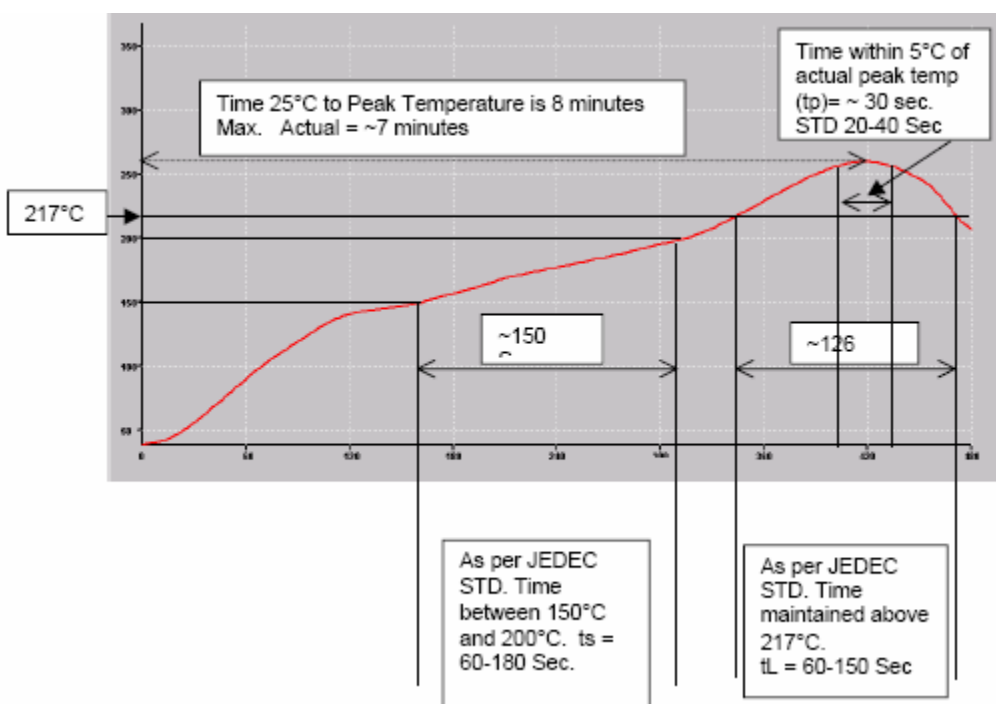

CDMA Cellular Band PA/Duplexer Module

Package Dimensions

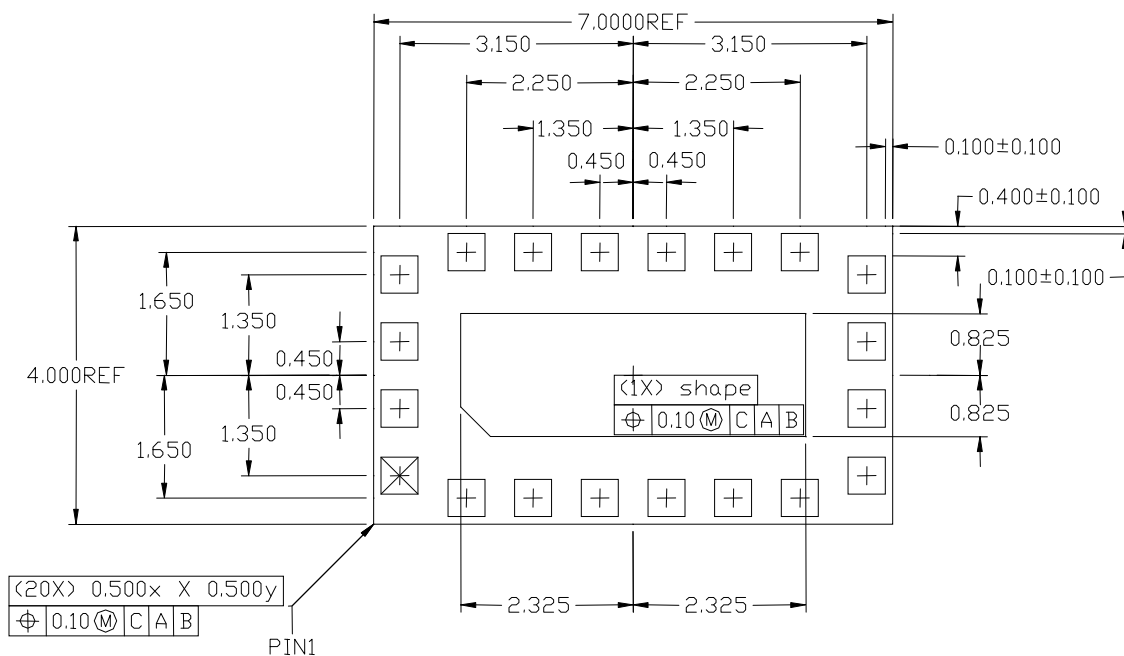

Figure 8: Package Drawing
Top View (X-ray)

Note: Height is 1.28mm typical / 1.38mm maximum

CDMA Cellular Band PA/Duplexer Module

Package Marking

TOP MARK



- 1) Line 1: Product code = TQM613025
- 2) Line 2: Country Code = CCCC (USA = United States, PHIL = Philippines)
- 3) Line 3: AaXXXX-Z = Aa = Vendor code + XXXX = TriQuint Lot Number + Z = Sub lot # (1, 2, 3, ...)
- 4) Line 4: YYWW = Year and Work Week

Tape and Reel Specification:

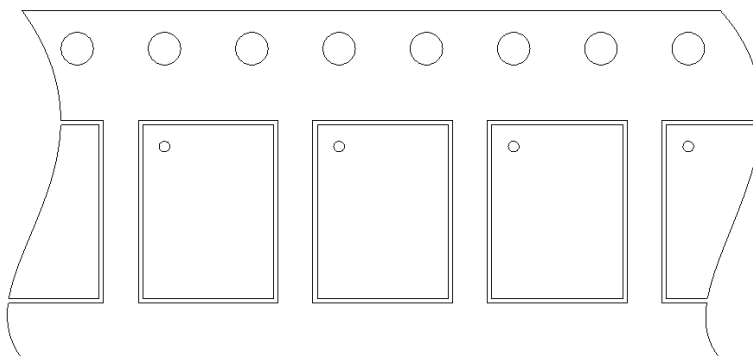

MODULE 4x7 and 5x8
User Direction of Feed →

Carrier tape - 3M part # 3M053091, Ao = 4.55mm, Bo = 7.60mm, Ko = 1.73mm, width = 16mm, pitch = 8mm
Cover tape - 3M part # 2678 13.3mm wide

Note: Package Quantity is 2,500 pcs per reel

CDMA Cellular Band PA/Duplexer Module

Shipment Box & Label Description:

Tape & Reels will be packaged in a dry-pack bag and then in a shipment box. The box dimensions will depend on the number of reels shipped in each box and are noted in the table below. The box label and a description of each item on the label are also shown below.

13 Inch x16mm--Drypack		
Box Size	Reel Qty/Box	Empty Box Wt w/ Packing
15x15x7	3	2
18x15x11	5	2.36
17x16x17	9	2.76

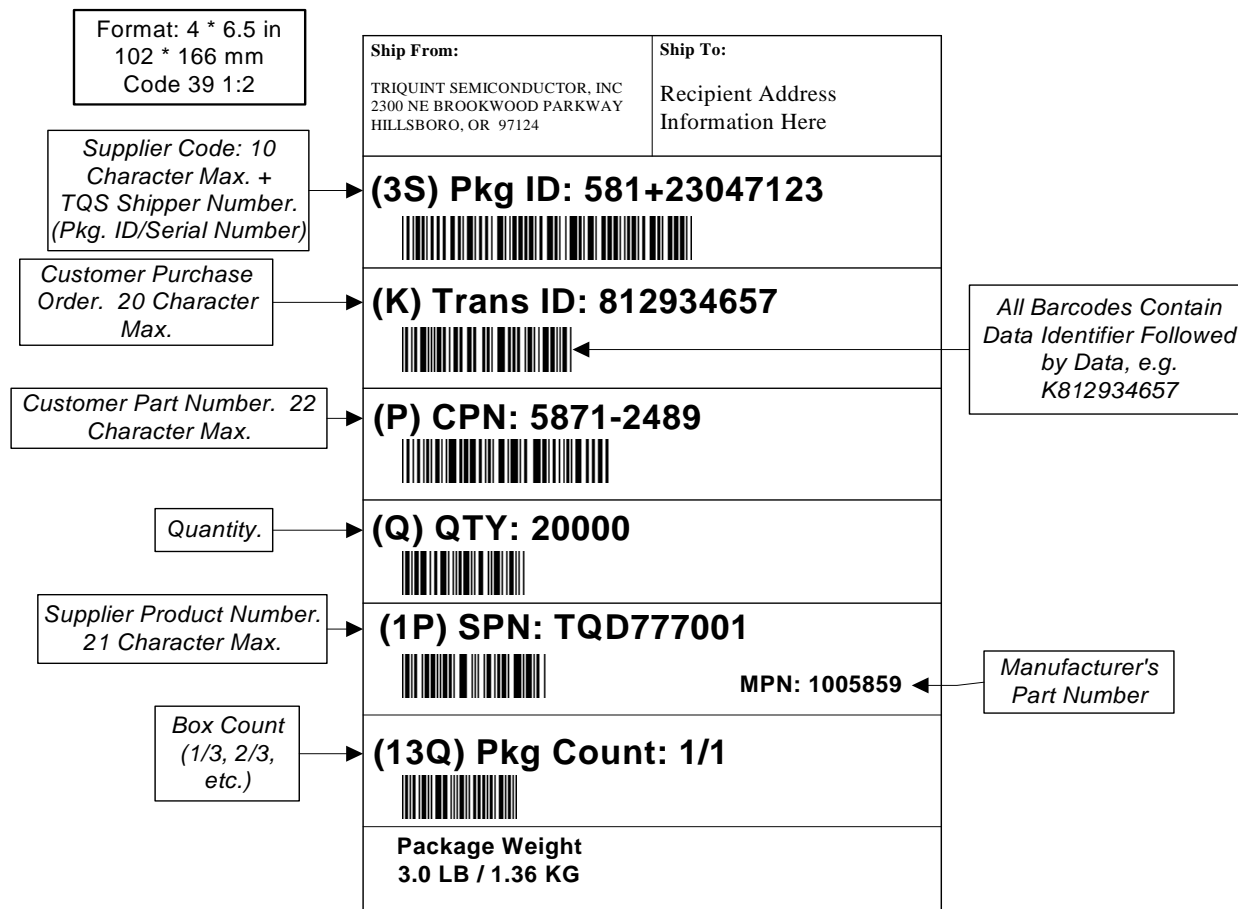

CDMA Cellular Band PA/Duplexer Module

Additional Information¹ T

This part is compliant with RoHS directive (Restrictions on the Use of Certain Hazardous Substances in Electrical and Electronic Equipment).

The part is rated Moisture Sensitivity Level 3 at 260°C per JEDEC standard IPC/JEDEC J-STD-020.

TQM613025 7.0 x 4.0 x 1.2 mm package has gold (Au) plated contacts.

¹ For latest specifications, additional product information, worldwide sales and distribution locations, and information about TriQuint:

Web: www.triquint.com

Tel: (503) 615-9000

Email: info_wireless@tqs.com

Fax: (503) 615-8902

For technical questions and additional information on specific applications:

Email: info_wireless@tqs.com

The information provided herein is believed to be reliable; TriQuint assumes no liability for inaccuracies or omissions. TriQuint assumes no responsibility for the use of this information, and all such information shall be entirely at the user's own risk. Prices and specifications are subject to change without notice. No patent rights or licenses to any of the circuits described herein are implied or granted to any third party.

TriQuint does not authorize or warrant any TriQuint product for use in life-support devices and/or systems.

Copyright © 2004-5 TriQuint Semiconductor, Inc. All rights reserved.