

3V Quad-Band GSM850/900 DCS/PCS Transmit Module

Functional Block Diagram

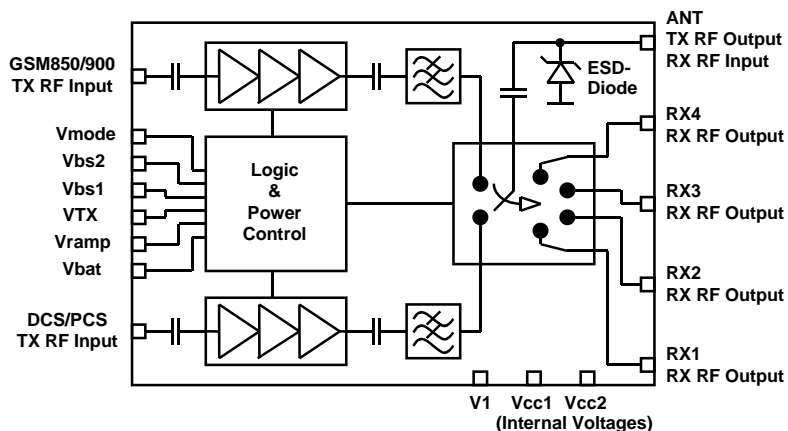

Product Description

The advanced quad-band Transmit Module designed for mobile handset applications provides full RF transmit functionality in a size of only 36 mm². The GSM850/900 and DCS/PCS power amplifier blocks including power control are combined with the low insertion loss quad-band pHEMT switch, Tx harmonics filtering, integrated switch decoder, four receive ports, and full ESD protection. This architecture eliminates the need for any PA-to-switch design effort for phone designers. All four Rx ports are frequency independent and allow flexible routing to the transceiver. Fabricated in high-reliability InGaP HBT / pHEMT technology, the module supports GPRS class 12 operation and provides 50 Ohms input and output impedances at all RF input and output ports. The module control inputs are CMOS compatible and *has no need for an external reference voltage*. With its excellent efficiency performance in all 4 bands, the power amplifier and switch module contributes to the overall talk-time targets of next generation mobile handset designs.

Features

- Ultra Compact Size – 6.0x6.0x1.1mm³.
- High System Efficiency – GSM850 40%, GSM900 45% , DCS/PCS 38%
- Integrated Power and SP6T Control
- Integrated SP6T pHEMT Switch
- Free choice of Rx ports for band selection
- Integrated Low Pass Tx Harmonics Filter
- Positive Supply Voltage 3.0 to 4.5 V.
- 50 Ω Input and Output Impedances.
- GPRS Class 12 Compatible.
- CMOS Compatible Module Control Inputs.
- High-Reliability InGaP HBT Technology
- Ruggedness 30:1.

Applications

- GSM GPRS Handsets and Modems
- Dual-, Tri-, Quad-band Class 12 Compatible

Package Style

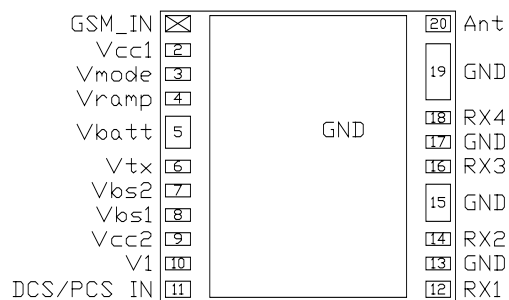

Advance Data Sheet: Subject to change without notice

For additional information and latest specifications, see our website: www.triquint.com

Revision 2.23, February 03, 2005

3V Quad-Band GSM850/900 DCS/PCS Transmit Module

Absolute Maximum Ratings

Symbol	Parameter	Conditions	Absolute Maximum Value	Units
V _{Batt}	Positive Supply Voltage		-0.5 to 5.5	V
V _{mod_en}	Module enable		-0.5 to 3.0	V
V _{TX}	Tx enable		-0.5 to 3.0	V
V _{BS1}	Band select 1		-0.5 to 3.0	V
V _{BS2}	Band select 2		-0.5 to 3.0	V
V _{ramp}	Power Control Voltage		-0.5 to 3.0	V
I _{Batt}	DC Supply Current		2.5 max	A
δ	PA Duty Cycle at Maximum Power		50 max [pulse time 2.3ms]	%
T _J	Junction Temperature		150 max	°C
T _{STORAGE}	Storage Temperature		-55 to +150	°C
T _C	Operating Case (ambient) Temperature		-30 to +100	°C
P _{in}	Maximum input power	RF input power applied	10	dBm
	ESD ruggedness at Antenna port	IEC 61000 – 4 – 2 (330 Ω, 150 pF)	8000 ¹⁾	V
	ESD ruggedness at Rx ports	HBM (1500 Ω, 100 pF)	250	V
	ESD ruggedness at all other ports	HBM (1500 Ω, 100 pF)	1000	V

Note: The transmit module will survive over the full range of specified maximum ratings for any individual parameter, while all other parameters are nominal and no RF input signal is applied (unless otherwise stated).

¹⁾ Requires external inductor. Without external inductor, the ESD ruggedness at the antenna port is 4 kV according to IEC 61000-4-2. Please refer to the application note for further application details.

3V Quad-Band GSM850/900 DCS/PCS Transmit Module

Operating Parameters

Parameter	Symbol	Conditions	Min.	Typ.	Max.	Units
Supply Voltage	Vbatt		3.0	3.5	4.5	V
Transmit Enable	VTX					
	VTXon	Logic High: PA ON	1.8		3.0	V
	VTXoff	Logic Low: PA OFF	0		0.5	V
	Current	Logic High: PA ON	-10		10	μA
	Current	Logic Low: PA OFF	-5		5	μA
	Switching time	Vramp from 0.2-2.0V			0.5	μA
Module Enable	Vmod_en					
	Vmod_En on	Logic High: Module ON	1.8		3.0	V
	Vmod_En off	Logic Low: Module OFF	0		0.5	V
	On current	Logic High: Module ON	-10		10	μA
	Off current	Logic Low: Module OFF	-5		5	μA
	Switching time				0.5	μS
Band Select 1	VBS1					
	High		1.8		3.0	V
	Low		0		0.5	V
	Band Select current High		-10		10	μA
	Band Select current Low		-5		5	μA
Band Select 2	VBS2					
	High		1.8		3.0	V
	Low		0		0.5	V
	Band Select current High		-10		10	μA
	Band Select current Low		-5		5	μA

3V Quad-Band GSM850/900 DCS/PCS Transmit Module

Operating Parameters (cont'd)

Parameter	Symbol	Conditions	Min.	Typ.	Max.	Units
Analog power control						
Voltage	Vramp		0.2		1.7	V
Current	Iramp			10	50	μA
Input impedance			100			kΩ
Power Supply Current	Ibatt	VTX = High, VBS1 = Low		1.6	2.5	A
GSM [PoutMax]						
Power Supply Current	Ibatt	VTX = High, VBS1 = High		0.9	2.5	A
DCS [PoutMax]						
Leakage Current (Sleep Mode)	Ibatt off	Vmod_en = Low, VTX = low, VBS1 = VBS2 = low	0.1	2	10	μA
Rx Current	Ibatt_RX	Vmod_en = High, VTX = Low, VBS1 = VBS2 = low/high* Vbatt = 3.5 V	0.1	50	500	μA
Input/Output impedance						
				50		Ω
RF power turn-on time						
				0.8		μs
RF power turn-off time						
				0.8		μs

* Either low or High State

Truth Table

Operating Mode	Control Voltage			
	Vmod_en	VTX	VBS1	VBS2
Tx-GSM 850/900	High	High	Low	Low / High*
Tx-DCS/PCS	High	High	High	Low / High*
Rx 1	High	Low	Low	Low
Rx 2	High	Low	Low	High
Rx 3	High	Low	High	Low
Rx 4	High	Low	High	High
Sleep Mode	Low	Low	Low	Low

* Either low or High State

All 4 Rx ports can be used for any frequency band, there is no frequency selecting element at each port.

Advance Data Sheet: Subject to change without notice

For additional information and latest specifications, see our website: www.triquint.com

Revision 2.23, February 03, 2005

3V Quad-Band GSM850/900 DCS/PCS Transmit Module

GSM 850 Electrical Characteristics:

Nominal Conditions (unless otherwise specified): V_{batt}=3.5V, V_{ramp}=1.7V, P_{in}=6dBm, VTX= High, T_a = 25°C, duty cycle = 50% , VBS1 =Low, VBS2 =Low , V_{mod_en} = High

Parameter	Symbol	Conditions	Min.	Typ.	Max.	Units
Frequency	f _{min} ..f _{max}		824		849	MHz
Input Power	P _{in}		4	6	8	dBm
Maximum Output Power	P _{out_max}	Nominal conditions	32.5	34		dBm
		V _{batt} = 3.0V, T _a = -30°C to 85°C	31.0			dBm
System Efficiency [PAE]		Nominal conditions		40		%
Minimum Output Power	P _{out_min}	V _{batt} = 3.5V, VTX = High, V _{ramp} = 0.2V, P _{in} = Pin _{max}		-10	0	dBm
Forward Leakage Power at Antenna	Iso_Ant	VTX = Low, P _{in} = Pin _{max}		-62	-58	dBm
Tx-Rx Leakage Power	Iso_Rx	P _{in} = Pin _{max} , Rx1, Rx2, Rx3, Rx4		-5	5	dBm
Output Noise Power		BW=100kHz				
869 MHz .. 894 MHz		f _o = 849 MHz		-85	-83	dBm
Input VSWR		VTX = low or high, 0.2V ≤ V _{ramp} ≤ 1.7V		1.5:1	3:1	
Stability	VSWR	4 dBm ≤ P _{in} ≤ 8 dBm, P _{out} ≤ 33 dBm	20:1			
All spurious < - 36dBm		3.0V ≤ V _{Batt} ≤ 4.5V, -30°C ≤ T _a ≤ 85°C				
No oscillations, all angles						
Ruggedness	VSWR	4 dBm ≤ P _{in} ≤ 8 dBm, P _{out} ≤ 33 dBm	30:1			
No permanent performance degradation, all angles		3.0V ≤ V _{Batt} ≤ 4.5V, -30°C ≤ T _a ≤ 85°C				
Harmonics						
H2, H3		P _{out} ≤ 33 dBm		-38	-34	dBm
All other harmonics up to 13 GHz		P _{out} ≤ 33 dBm		-40	-35	dBm
Power Control Slope		P _{out} > 12dBm			150	
P _{out} /V _{ramp}		5 dBm ≤ P _{out} ≤ 12 dBm			250	dB/V
Power Accuracy						
P _{out} > 31 dBm		-30°C ≤ T _a ≤ 85°C, 3.0V ≤ V _{Batt} ≤ 4.2V, P _{in} = 6 dBm		± 1.0	+1.5/-2.0	
11dBm < P _{out} ≤ 31 dBm				± 1.5	± 3	dB
5dBm ≤ P _{out} ≤ 11 dBm				± 2.0	± 4	

Advance Data Sheet: Subject to change without notice

For additional information and latest specifications, see our website: www.triquint.com

Revision 2.23, February 03, 2005

3V Quad-Band GSM850/900 DCS/PCS Transmit Module

GSM 900 Electrical Characteristics:

Nominal Conditions (unless otherwise specified): Vbatt=3.5V, Vramp=1.7V, Pin=6dBm, VTX= High, Ta = 25°C, duty cycle = 50% , VBS1 =Low, VBS2 =Low , Vmod_en = High

Parameter	Symbol	Conditions	Min.	Typ.	Max.	Units
Frequency	fmin..fmax		880		915	MHz
Input Power	Pin		4	6	8	dBm
Maximum Output Power	Pout_max	Nominal conditions	32.5	34		dBm
		Vbatt = 3.0V, Ta = -30°C to 85°C	31.0			dBm
System Efficiency [PAE]		Nominal conditions		44		%
Minimum Output Power	Pout_min	Vbatt = 3.5V, VTX = High, Vramp = 0.2V, Pin = Pinmax		-10	0	dBm
Forward Leakage Power at Antenna	Iso_Ant	VTX = Low, Pin = Pinmax		-62	-58	dBm
Tx-Rx Leakage Power	Iso_Rx	Pin = Pinmax, Rx1, Rx2, Rx3, Rx4		-5	5	dBm
Output Noise Power		BW=100kHz				
925 MHz..935 MHz		fo = 915 MHz		-81	-78	dBm
935 MHz..960 MHz		fo = 915 MHz		-85	-83	
Input VSWR		VTX = low or high, 0.2V ≤ Vramp ≤ 1.7V		1.5:1	3:1	
Stability	VSWR	4 dBm ≤ Pin ≤ 8 dBm, Pout ≤ 33 dBm	20:1			
All spurious < -36dBm		3.0V ≤ VBatt ≤ 4.5V, -30°C ≤ Ta ≤ 85°C				
No oscillations, all angles						
Ruggedness	VSWR	4 dBm ≤ Pin ≤ 8 dBm, Pout ≤ 33 dBm	30:1			
No permanent performance degradation, all angles		3.0V ≤ VBatt ≤ 4.5V, -30°C ≤ Ta ≤ 85°C				
Harmonics						
H2, H3		Pout ≤ 33 dBm		-40	-34	dBm
H2		Pout ≤ 33 dBm, fo = 900 – 915 MHz		-44	-38	dBm
All other harmonics up to 13 GHz		Pout ≤ 33 dBm		-40	-35	dBm
Power Control Slope		Pout > 12dBm			150	
Pout/Vramp		5 dBm ≤ Pout ≤ 12 dBm			250	dB/V
Power Accuracy						
Pout > 31 dBm		-30°C ≤ Ta ≤ 85°C		± 1.0	+1.5/-2.0	
11dBm < Pout ≤ 31 dBm		3.0V ≤ VBatt ≤ 4.2V		± 1.5	± 3	dB
5dBm ≤ Pout ≤ 11 dBm		Pin = 6 dBm		± 2.0	± 4	

Advance Data Sheet: Subject to change without notice

For additional information and latest specifications, see our website: www.triquint.com

Revision 2.23, February 03, 2005

3V Quad-Band GSM850/900 DCS/PCS Transmit Module

DCS Electrical Characteristics:

Nominal Conditions (unless otherwise specified): V_{batt}=3.5V, V_{ramp}=1.7V, P_{in}=6dBm, VTX= High, T_a = 25°C, duty cycle = 50% , VBS1 = High, VBS2 =Low , V_{mod_en} = High

Parameter	Symbol	Conditions	Min.	Typ/No m	Max.	Units
Frequency	fmin..fmax		1710		1785	MHz
Input Power	P _{in}		4	6	8	dBm
Maximum Output Power	P _{out_max}	Nominal conditions	30.5	31.5		dBm
		V _{batt} = 3.0V, T _a =-30°C to 85°C	29.0			dBm
System Efficiency [PAE]		Nominal conditions		38		%
Minimum Output Power	P _{out_min}	V _{batt} = 3.0V, VTX = High, V _{ramp} = 0.2V, P _{in} = Pinmax		-12	-5	dBm
Forward Leakage Power at Antenna	Iso_Ant	VTX = Low, P _{in} = Pinmax		-55	-50	dBm
Tx-Rx Leakage Power	Iso_Rx	P _{in} = Pinmax, Rx1, Rx2, Rx3, Rx4		0	5	dBm
Output Noise Power		BW=100kHz				
1805 MHz..1880 MHz		f _o = 1785 MHz		-80	-76	dBm
Input VSWR		VTX = low or high, 0.2V ≤ V _{ramp} ≤1.7V		1.5:1	3:1	
Stability	VSWR	4 dBm ≤ P _{in} ≤ 8 dBm, P _{out} ≤ 30.5 dBm	15:1			
All spurious < - 36dBm		3.0V ≤ V _{Batt} ≤ 4.5V, -30°C ≤ T _a ≤ 85°C				
No oscillations, all angles						
Ruggedness	VSWR	4 dBm ≤ P _{in} ≤ 8 dBm, P _{out} ≤ 30.5 dBm	20:1			
No permanent performance degradation, all angles		3.0V ≤ V _{Batt} ≤ 4.5V, -30°C ≤ T _a ≤ 85°C				
Harmonics						
H2, H3		P _{out} ≤ 30 dBm		-40	-34	dBm
All other harmonics up to 13 GHz		P _{out} ≤ 30 dBm		-40	-35	dBm
Power Control Slope		P _{out} > 12dBm			150	
P _{out} /V _{ramp}		5 dBm ≤ P _{out} ≤ 12 dBm			200	
		0 dBm ≤ P _{out} < 5 dBm			250	dB/V
Power Accuracy						
P _{out} > 28 dBm				± 1.0	+1.5	dB
12dBm < P _{out} ≤28 dBm		-30°C ≤ T _a ≤ 85°C, 3.0V ≤ V _{Batt} ≤ 4.2V, P _{in} = 6 dBm		± 1.5	± 2	dB
2dBm ≤ P _{out} ≤12 dBm				± 2.0	+3/-5	dB
0 dBm ≤ P _{out} ≤12 dBm				± 2.0	+4/-5.5	dB

Advance Data Sheet: Subject to change without notice

For additional information and latest specifications, see our website: www.triquint.com

Revision 2.23, February 03, 2005

3V Quad-Band GSM850/900 DCS/PCS Transmit Module

PCS Electrical Characteristics:

Nominal Conditions (unless otherwise specified): V_{batt}=3.5V, V_{ramp}=1.7V, P_{in}=6dBm, VTX= High, T_a = 25°C, duty cycle = 50% , VBS1 = High, VBS2 =Low , V_{mod_en} = High

Parameter	Symbol	Conditions	Min.	Typ.	Max.	Units
Frequency	f _{min} ..f _{max}		1850		1910	MHz
Input Power	P _{in}		4	6	8	dBm
Maximum Output Power	P _{out_max}	Nominal conditions	30.5	31.5		dBm
		V _{batt} = 3.0V, T _a = -30°C to 85°C	29.0			dBm
System Efficiency [PAE]		Nominal conditions		38		%
Minimum Output Power	P _{out_min}	V _{batt} = 3.0V, VTX = High, V _{ramp} = 0.2V, P _{in} = Pinmax		-12	-5	dBm
Forward Leakage Power at Antenna	Iso_Ant	VTX = Low, P _{in} = Pinmax		-55	-50	dBm
Tx-Rx Leakage Power	Iso_Rx	P _{in} = Pinmax, Rx1, Rx2, Rx3, Rx4		0	5	dBm
Output Noise Power 1930 MHz..1990 MHz		BW=100kHz				
		fo = 1910 MHz		-80	-76	dBm
Input VSWR		VTX = low or high, 0.2V ≤ V _{ramp} ≤ 1.7V		1.5:1	3:1	
Stability	VSWR	4 dBm ≤ P _{in} ≤ 8 dBm, P _{out} ≤ 30.5 dBm	15:1			
All spurious < - 36dBm		3.0V ≤ V _{Batt} ≤ 4.5V, -30°C ≤ T _a ≤ 85°C				
No oscillations, all angles						
Ruggedness	VSWR	4 dBm ≤ P _{in} ≤ 8 dBm, P _{out} ≤ 30.5 dBm	20:1			
No permanent performance degradation, all angles		3.0V ≤ V _{Batt} ≤ 4.5V, -30°C ≤ T _a ≤ 85°C				
Harmonics						
H2, H3		P _{out} ≤ 30 dBm		-40	-34	dBm
All other harmonics up to 13 GHz		P _{out} ≤ 30 dBm		-40	-35	dBm
Power Control Slope		P _{out} > 12dBm			150	
P _{out} /V _{ramp}		5 dBm ≤ P _{out} ≤ 12 dBm			200	
		0 dBm ≤ P _{out} < 5 dBm			250	dB/V
Power Accuracy						
P _{out} > 28 dBm				± 1.0	+1.5	dB
12dBm < P _{out} ≤ 28 dBm		-30°C ≤ T _a ≤ 85°C, 3.0V ≤ V _{Batt} ≤ 4.2V, P _{in} = 6 dBm		± 1.5	± 2	dB
2dBm ≤ P _{out} ≤ 12 dBm				± 2.0	+3/-5	dB
0 dBm ≤ P _{out} ≤ 2 dBm				± 2.0	+4/-5.5	dB

Advance Data Sheet: Subject to change without notice

For additional information and latest specifications, see our website: www.triquint.com

Revision 2.23, February 03, 2005

3V Quad-Band GSM850/900 DCS/PCS Transmit Module

Rx1 Receive Mode Electrical Characteristics:

Nominal Conditions: VBS1 =Low, VBS2 =Low, Vbatt=3.5V, Vramp=0.2 .. 1.7V, VTX = Low, Vmod_en = High , Ta = 25°C, duty cycle = 50%

Parameter	Symbol	Conditions	Min.	Typ.	Max.	Units
Frequency	fmin..fmax		869		1990	MHz
Insertion Loss GSM	lloss	Nominal Conditions, 869MHz < f < 960 MHz			1.1	dB
		Vbatt=3.0V,Ta=85°C, 869MHz < f < 960 MHz			1.3	dB
Insertion Loss DCS	lloss	Nominal Conditions, 1805MHz < f < 1990 MHz			1.3	dB
		Vbatt=3.0V,Ta=85°C, 1805MHz < f < 1990 MHz			1.5	dB
ANT-Rx2,3,4 Isolation	Iso_Rx	Vbatt=3.0V, Tc=-30°C to 85°C	25			dB
Inband Ripple 1	lripp	869MHz-960MHz			0.2	dB
Inband Ripple 2	lripp	1805MHz-1990MHz			0.5	dB
VSWR [Rx1 and Ant]					1.5:1	
Terminating Impedance				50		Ω

Rx2 Receive Mode Electrical Characteristics:

Nominal Conditions: VBS1 =Low, VBS2 =High, Vbatt=3.5V, Vramp=0.2 .. 1.7V, VTX = Low, Vmod_en = High , Ta = 25°C, duty cycle = 50%

Parameter	Symbol	Conditions	Min.	Typ.	Max.	Units
Frequency	fmin..fmax		869		1990	MHz
Insertion Loss GSM	lloss	Nominal Conditions, 869MHz < f < 960 MHz			1.1	dB
		Vbatt=3.0V,Ta=85°C, 869MHz < f < 960 MHz			1.3	dB
Insertion Loss DCS	lloss	Nominal Conditions, 1805MHz < f < 1990 MHz			1.3	dB
		Vbatt=3.0V,Ta=85°C, 1805MHz < f < 1990 MHz			1.5	dB
ANT-Rx1,3,4 Isolation	Iso_Rx	Vbatt=3.0V, Tc=-30°C to 85°C	25			dB
Inband Ripple 1	lripp	869MHz-960MHz			0.2	dB
Inband Ripple 2	lripp	1805MHz-1990MHz			0.5	dB
VSWR [Rx1 and Ant]					1.5:1	
Terminating Impedance				50		Ω

Advance Data Sheet: Subject to change without notice

For additional information and latest specifications, see our website: www.triquint.com

Revision 2.23, February 03, 2005

3V Quad-Band GSM850/900 DCS/PCS Transmit Module

Rx3 Receive Mode Electrical Characteristics:

Nominal Conditions: VBS1 =High, VBS2 =Low, Vbatt=3.5V, Vramp=0.2 .. 1.7V, VTX = Low, Vmod_en = High , Ta= 25°C, duty cycle = 50%

Parameter	Symbol	Conditions	Min.	Typ.	Max.	Units
Frequency	fmin..fmax		869		1990	MHz
Insertion Loss GSM	lloss	Nominal Conditions, 869MHz < f < 960 MHz			1.1	dB
		Vbatt=3.0V,Ta=85°C, 869MHz < f < 960 MHz			1.3	dB
Insertion Loss DCS	lloss	Nominal Conditions, 1805MHz < f < 1990 MHz			1.3	dB
		Vbatt=3.0V,Ta=85°C, 1805MHz < f < 1990 MHz			1.5	dB
ANT-Rx1,2,4 Isolation	Iso_Rx	Vbatt=3.0V, Tc=-30°C to 85°C	25			dB
Inband Ripple 1	lripp	869MHz-960MHz			0.2	dB
Inband Ripple 2	lripp	1805MHz-1990MHz			0.2	dB
VSWR [Rx3 and Ant]					1.5:1	
Terminating Impedance				50		Ω

Rx4 Receive Mode Electrical Characteristics:

Nominal Conditions: VBS1 =High, VBS2 =High, Vbatt=3.5V, Vramp=0.2 .. 1.7V, VTX = Low, Vmod_en = High , Ta= 25°C, duty cycle = 50%

Parameter	Symbol	Conditions	Min.	Typ.	Max.	Units
Frequency	fmin..fmax		869		1990	MHz
Insertion Loss GSM	lloss	Nominal Conditions, 869MHz < f < 960 MHz			1.1	dB
		Vbatt=3.0V,Ta=85°C, 869MHz < f < 960 MHz			1.3	dB
Insertion Loss DCS	lloss	Nominal Conditions, 1805MHz < f < 1990 MHz			1.3	dB
		Vbatt=3.0V,Ta=85°C, 1805MHz < f < 1990 MHz			1.5	dB
ANT-Rx1,2,3 Isolation	Iso_Rx	Vbatt=3.0V, Tc=-30°C to 85°C	25			dB
Inband Ripple 1	lripp	869MHz-960MHz			0.2	dB
Inband Ripple 2	lripp	1805MHz-1990MHz			0.2	dB
VSWR [Rx4 and Ant]					1.5:1	
Terminating Impedance				50		Ω

Advance Data Sheet: Subject to change without notice

For additional information and latest specifications, see our website: www.triquint.com

Revision 2.23, February 03, 2005

3V Quad-Band GSM850/900 DCS/PCS Transmit Module

Phone Board Circuit Recommendation

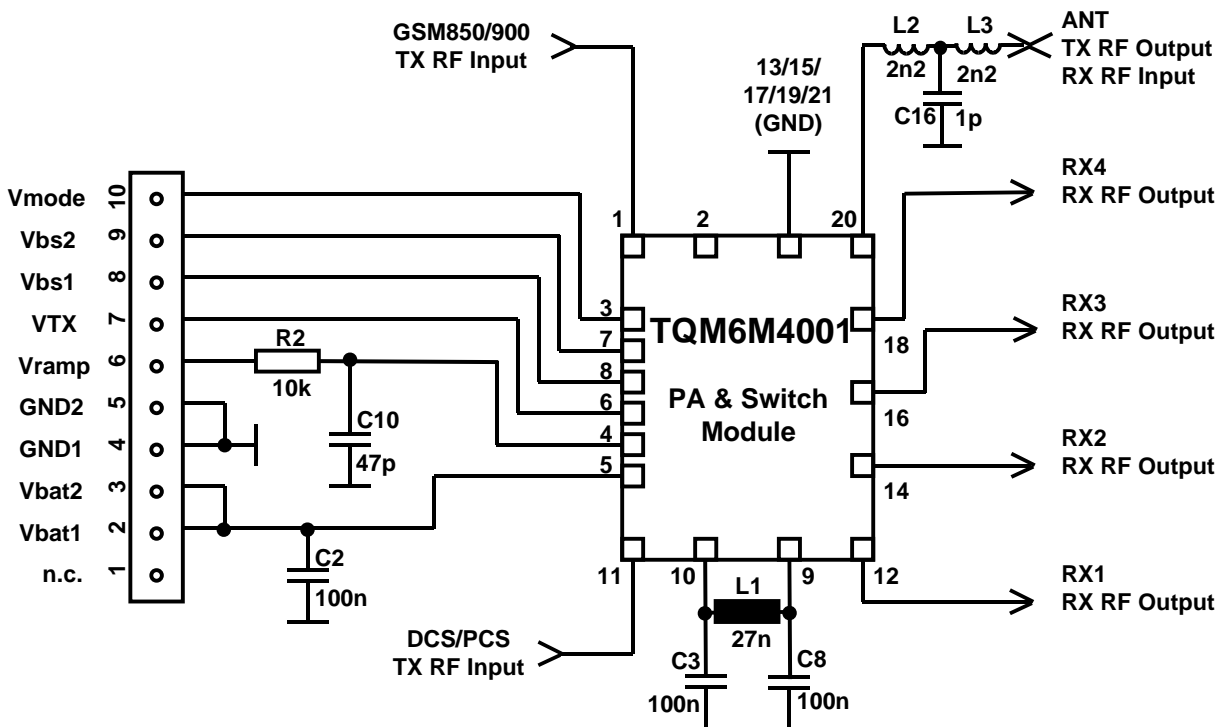

C2, C3	100 nF	RF bypass capacitors
C8	10 nF	RF bypass capacitors
L1	27 nH	Decoupling inductor
L2, L3	2.2 nH	Low Pass Filter
C16	1 pF	Low Pass Filter
R1, C10		Depending on base band IC

Please refer to the application note for further application details

Advance Data Sheet: Subject to change without notice

For additional information and latest specifications, see our website: www.triquint.com

Revision 2.23, February 03, 2005

3V Quad-Band GSM850/900 DCS/PCS Transmit Module

Pin Out

TOP VIEW

PIN DESIGNATIONS

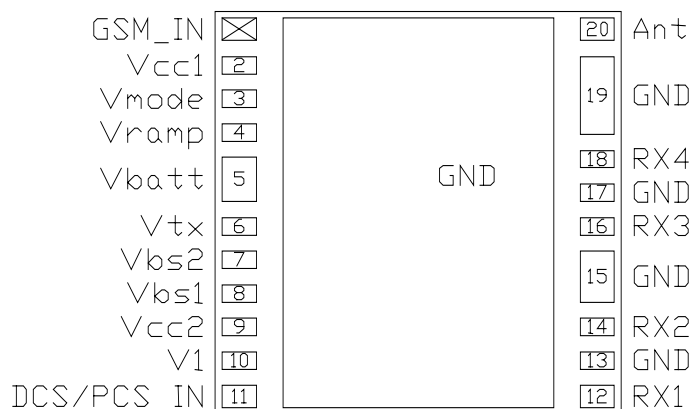

Pin	Symbol	Description
1	GSM850 / 900 in	GSM850 / GSM900 RF input
2	Vcc1	Internal Voltage
3	Vmod_en	Digital Module Enable Signal: When activated (Vmod_en = high), the PA & Switch module will be enabled for operation.
4	Vramp	DAC Control Signal for output power setting, nominal 0.2 .. 1.7 V
5	Vbatt	Battery supply voltage, typ. 3.0 – 4.7 V, nom. 1.6A GSM
6	VTX	Digital Transmit Enable Signal. When activated (TX_EN = high), all bands of the PA will be enabled for operation.
7	VBS2	Band Select Pin 2 (cf. Truth table on p. 8)
8	VBS1	Band Select Pin 1 (cf. Truth table on p. 8)
9	Vcc2	Internal Voltage
10	V1	Internal Voltage; external connection to Vcc2 required
11	DCS/PCS in	DCS/PCS input
12	Rx1	Rx1 output
13	GND	Ground
14	Rx2	Rx2 output
15	GND	Ground
16	Rx3	Rx3 output
17	GND	Ground
18	Rx4	Rx4 output
19	GND	Ground
20	ANT	Antenna port
21	GND	Ground

Advance Data Sheet: Subject to change without notice

For additional information and latest specifications, see our website: www.triquint.com

Revision 2.23, February 03, 2005

3V Quad-Band GSM850/900 DCS/PCS Transmit Module

Package Dimensions

Top View

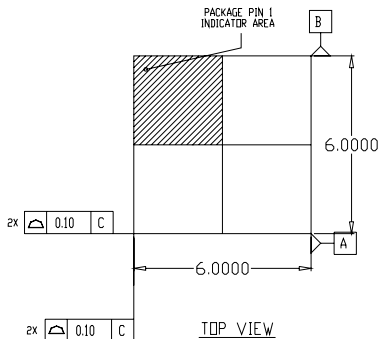

Side View

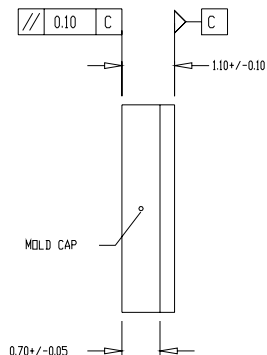

Bottom View

(13X) 0.500x X 0.250y

A $\text{0.10} \text{ } \text{C} \text{ } \text{A} \text{ } \text{B}$

(4X) 0.500x X 0.325y

B $\text{0.10} \text{ } \text{C} \text{ } \text{A} \text{ } \text{B}$

(1X) 0.500x X 0.650y

C $\text{0.10} \text{ } \text{C} \text{ } \text{A} \text{ } \text{B}$

(1X) 0.500x X 1.150y

D $\text{0.10} \text{ } \text{C} \text{ } \text{A} \text{ } \text{B}$

(1X) 0.500x X 0.750y

E $\text{0.10} \text{ } \text{C} \text{ } \text{A} \text{ } \text{B}$

BOTTOM VIEW

Dimensions nominal (mm)

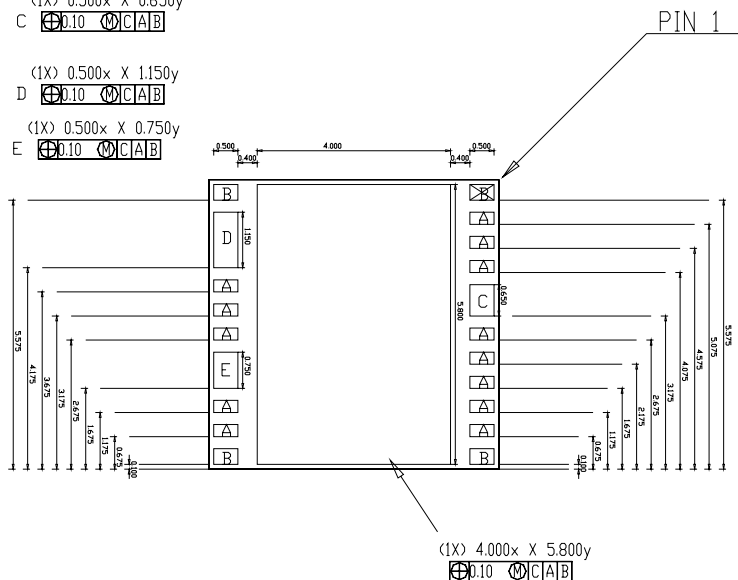

Advance Data Sheet: Subject to change without notice

For additional information and latest specifications, see our website: www.triquint.com

Revision 2.23, February 03, 2005

3V Quad-Band GSM850/900 DCS/PCS Transmit Module

PCB Footprint Recommendation

TOP VIEW
PCB FOOTPRINT
SOLDERMASK
RECOMMENDATIONS

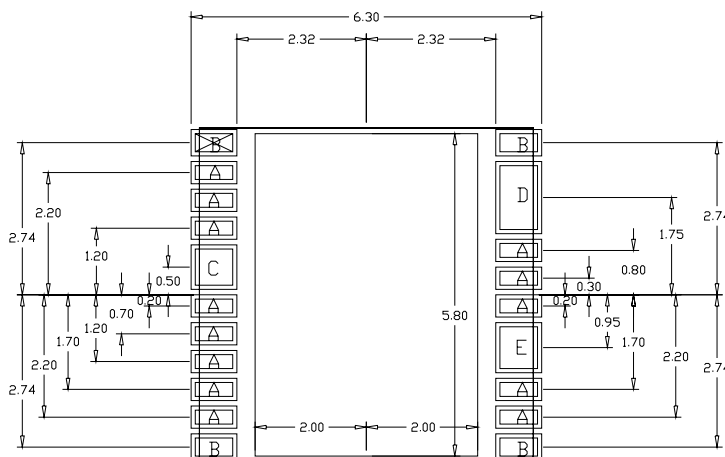

TOP VIEW
PCB FOOTPRINT
ETCH
RECOMMENDATIONS

- (13X) 0.675x X 0.250y
A
- (4X) 0.675x X 0.325y
B
- (1X) 0.675x X 0.650y
C
- (1X) 0.675x X 1.150y
D
- (1X) 0.675x X 0.750y
E

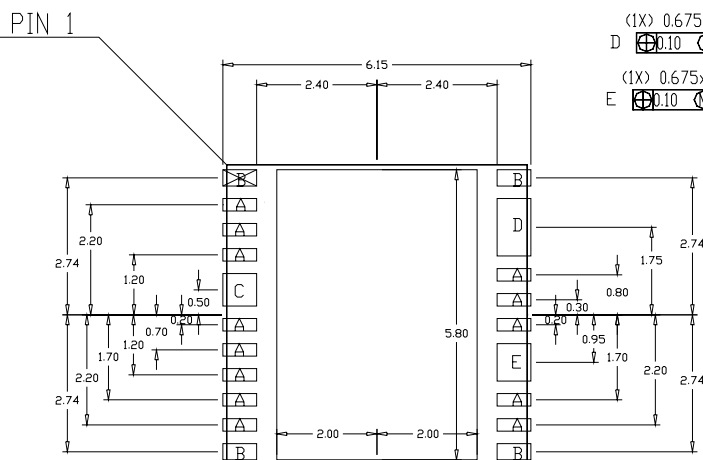

3V Quad-Band GSM850/900 DCS/PCS Transmit Module

Tape and Reel information

Module Orientation

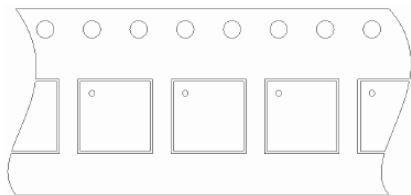

MODULE 6x6

User Direction of Feed →

Carrier and Cover Tape Physical Dimensions

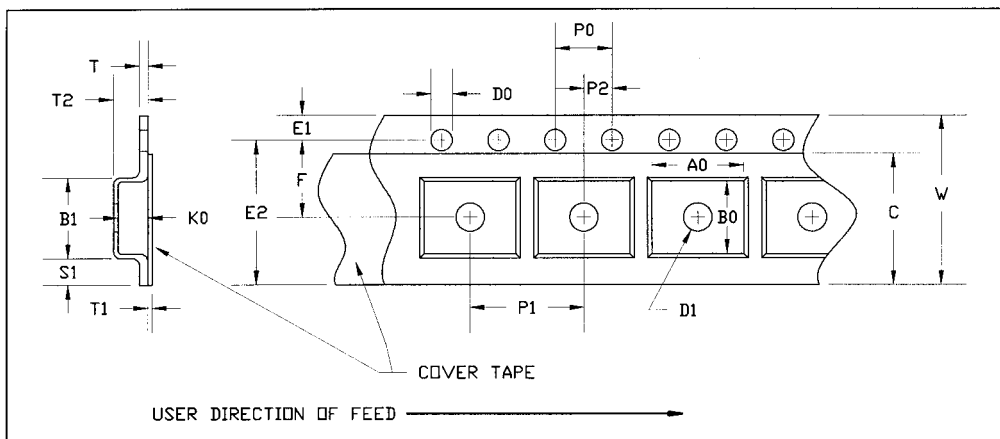

PART	FEATURE	SYMBOL	SIZE (in)	SIZE (mm)
CAVITY	BOTTOM HOLE DIAMETER	D1	0.059	1.50
PERFORATION	DIAMETER	D0	0.059	1.50
	PITCH	P0	0.157	4.00
	POSITION	E1	0.069	1.75
CARRIER TAPE	THICKNESS	T	0.012	0.30
COVER TAPE	THICKNESS	T1	0.002	0.056
CAVITY	LENGTH	A0	0.171	4.35
	WIDTH	B0	0.171	4.35
	DEPTH	K0	0.071	1.80
	PITCH	P1	0.315	8.00
DISTANCE BETWEEN CENTERLINE	CAVITY TO PERFORATION LENGTH DIRECTION	P2	0.079	2.00
	CAVITY TO PERFORATION WIDTH DIRECTION	F	0.217	5.50
COVER TAPE	WIDTH	C	0.362	9.20
CARRIER TAPE	WIDTH	W	0.472	12.00

Advance Data Sheet: Subject to change without notice

For additional information and latest specifications, see our website: www.triquint.com

Revision 2.23, February 03, 2005

3V Quad-Band GSM850/900 DCS/PCS Transmit Module

Reel Physical dimensions

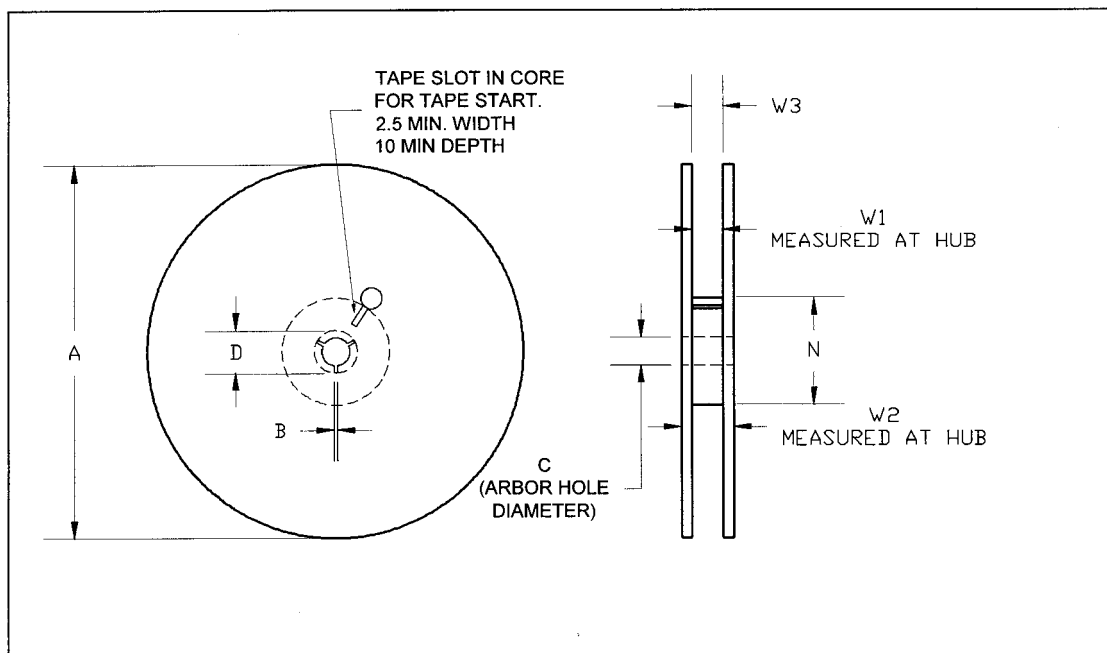

PART	FEATURE	SYMBOL	SIZE (in)	SIZE (mm)
FLANGE	DIAMETER	A	12.992	330.0
	THICKNESS	W2	0.874	22.2
	SPACE BETWEEN FLANGE	W1	0.661	16.8
HUB	OUTER DIAMETER	N	4.016	102.0
	ARBOR HOLE DIAMETER	C	0.512	13.0
	KEY SLIT WIDTH	B	0.079	2.0
	KEY SLIT DIAMETER	D	0.787	20.0

3V Quad-Band GSM850/900 DCS/PCS Transmit Module

Completed Tape and Reel Assembly

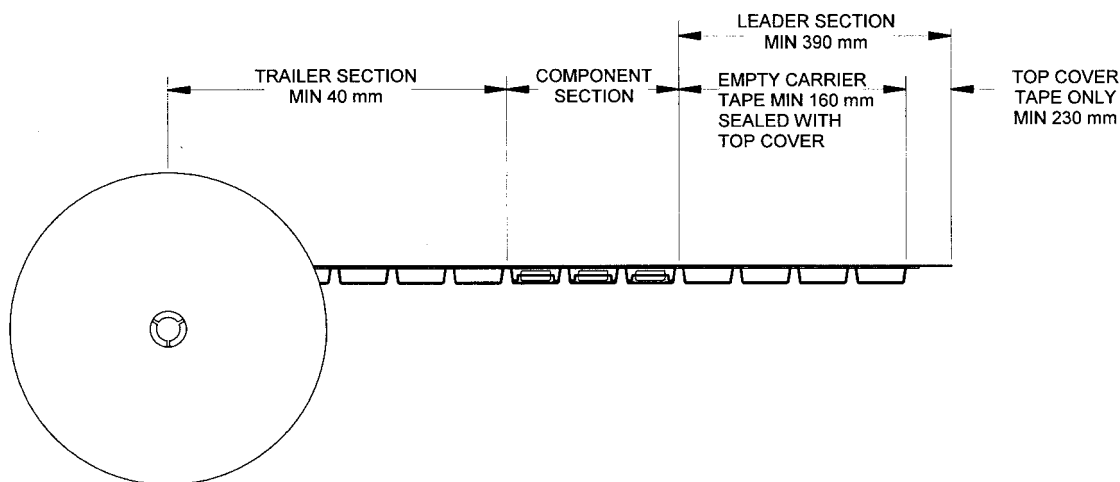

Product label, Mfg Label and ESD label are placed on the flange opposite to the sprockets in the carrier tape

