

**3V Quad-Band GSM850/900 DCS/PCS Power Amplifier Module**

**Description:**

Advanced quad-band, compact 3V power amplifier module designed for mobile handset applications. The small size and high performance is achieved with high-reliability InGaP HBT technology. The module is fully integrated, providing a simple 50 Ohms interface on all input and output ports. No external matching or bias components are required. Despite its very compact size, the module has exceptional efficiency in both bands. Band select and power control inputs on the module are CMOS compatible.

**Features:**

- **Very compact size – 8.75x9.55x1.32mm<sup>3</sup>.**
- **High efficiency – typical GSM850 52%, E-GSM 58%, DCS 52% , PCS 50%**
- **Positive supply voltage 3.1 to 5.2 V.**
- **50 Ω input and output impedances.**
- **GPRS class 12 compatible.**
- **CMOS band select and power control inputs.**
- **High-reliability InGaP technology.**
- **Ruggedness 10:1.**
- **Few external components.**
- **Very low input power levels**

<b>GSM850/900</b>	<b>-3dBm [min]</b>
<b>DCS/PCS</b>	<b>-5dBm [min]</b>

**Description:**

The module is a built around a highly integrated dual power amplifier InGaP die. By virtue of advanced design techniques, exceptional performance is achieved with four stages in each amplifier. On-die interstage matching is employed using a high Q passives technology. Together these technologies allow an extremely compact size to be achieved with excellent electrical performance. The module includes a CMOS die to implement a band-select function and Internal Power Control, avoiding additional external components like directional coupler, detector diode and operational amplifier. The module construction is a low-profile overmolded land-grid array on laminate.

**Package Outline:**

*Dimensions in mm / μm*

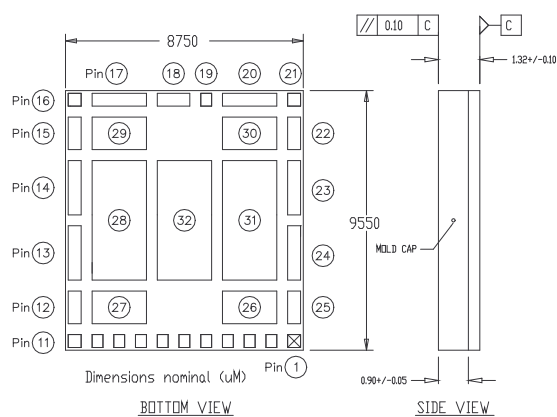

**Top view**



**Bottom view**



### Absolute Maximum Ratings:

Parameter	Symbol	Min.	Max.	Units
Supply voltage	$V_{bat}$	0	5.2	V
DC supply current	$I_{cc}$		2.4	A
Power control voltage	$V_{ramp}$	-0.5	1.7	V
Duty cycle at max. power	$\delta$		50	%
Operating case temperature	$T_C$	-25	95	°C
Storage temperature	$T_S$	-55	150	°C

*Note: The amplifier will survive over the full range specified for any individual input, while other parameters are nominal and with no RF input.*

### Operating Parameters:

Parameter	Symbol	Min.	Typ.	Max.	Units
Supply voltage	$V_{BATT}$	3.1	3.5	4.2	V
DC supply current	$I_{cc}$		1.6		A
Leakage current	$I_l$		7	10	$\mu A$
Load impedances	$Z_0$		50		$\Omega$

## Low Band (GSM 850/E-GSM) AC Characteristics:

Standard Conditions [unless otherwise stated] :

$V_{BATT} = +3.5V$ ,  $V_{RAMP} = 1.7V$ ,  $P_{IN} = +1 \text{ dBm}$ ,  $Tx\_Enable = H$ ,  $T_C = 35^\circ C$

Quantity	Symbol	Condition	Limits			Unit
			Min	Typ	Max	
Frequency Range	$f_{MIN} \dots f_{MAX}$		824 880		849 915	MHz
Input Power Range	$P_{IN\_MIN}$ $P_{IN\_TYP}$ $P_{IN\_MAX}$		-3	1	5	dBm
Output Power	$P_{OUT\_MAX}$	Standard Conditions	34	35		dBm
		$T_{CMIN} \leq T_C \leq T_{CMAX}$ $V_{BATT} = 3.1V$ $P_{IN} = P_{IN\_MIN}$	32.5	33		dBm
Efficiency (PAE)	$\eta$	$P_{OUT} = P_{OUT\_MAX}$ $f = 824 - 849 \text{ MHz}, P_{OUT} = P_{OUT\_MAX}$	45	52		%
		$f = 880 - 915 \text{ MHz}, P_{OUT} = P_{OUT\_MAX}$	50	58		%
Input VSWR		$5 \text{ dBm} < P_{OUT} < 34.5 \text{ dBm}$		1.5:1	2.5:1	
Stability (all phases)		$P_{OUT} \leq 34.5 \text{ dBm}$ 12.5% - 50% duty cycle No oscillations, All Non-harmonic spurious < -36dBm	8:1			
Ruggedness (all phases)		$P_{OUT} \leq 34.5 \text{ dBm}$ 12.5%-50% duty cycle	10:1			
Harmonics	2fo	$P_{OUT} \leq 34.5 \text{ dBm}$		-16	-8	dBm
	3fo	$T_{CMIN} \leq T_C \leq T_{CMAX}$		-20	-10	
Harmonics	4fo – 8fo	$P_{OUT} \leq 34.5 \text{ dBm}$ $T_{CMIN} \leq T_C \leq T_{CMAX}$			-5	dBm
Reverse Harmonic Level	4fo	$P_{OUT} \leq 34.5 \text{ dBm}$ $T_{CMIN} \leq T_C \leq T_{CMAX}$		-35		dBc

### Low Band (GSM 850/E-GSM) AC Characteristics (cont):

Rx band noise	Pnoise	5dBm ≤ P <sub>OUT</sub> ≤ 34.5dBm 869 MHz ≤ f ≤ 894 MHz RBW = 100kHz		-85	-83	dBm
		5dBm ≤ P <sub>OUT</sub> ≤ 34.5dBm RBW = 100kHz 925 MHz ≤ f ≤ 935 MHz 935 MHz ≤ f < 960 MHz		-85	-72 -83	dBm dBm
AM suppression @fo +20MHz		P <sub>OUT</sub> = P <sub>OUT_MAX</sub> P <sub>IN</sub> = P <sub>IN_MIN</sub>		13		dB
Cross Coupled Power (Power at DCS when GSM is active)		Band Select = Low , 2fo P <sub>IN</sub> = P <sub>IN_MAX</sub>			-20	dBm
Off Isolation		P <sub>IN</sub> ≤ P <sub>IN_MAX</sub> TX_Enable = L			-40	dBm
Slope P <sub>OUT</sub> / V <sub>RAMP</sub>		824 MHz ≤ f ≤ 849 MHz 880 MHz ≤ f ≤ 915 MHz 10dBm ≤ P <sub>OUT</sub> ≤ P <sub>OUT_MAX</sub> 0dBm ≤ P <sub>OUT</sub> ≤ 10dBm		<100		dB/V
				<150		dB/V
TX Enable switching time					2	μsec
Rise Time	τ <sub>R</sub>	Time from Pout = 0 dBm to Pout = P <sub>OUT_MAX</sub>			2	μsec
Fall Time	τ <sub>F</sub>	Time from Pout = P <sub>OUT_MAX</sub> to Pout = 0 dBm			2	
ESD Ruggedness		Human Body Model in Application Circuit [100pF/1500 Ohm] All ports	0.5			kV

## Low Band (GSM 850/E-GSM) : Typical performance

Standard Conditions [unless otherwise stated] :

$V_{BATT} = +3.5V$ ,  $V_{RAMP} = 1.7V$ ,  $P_{IN} = +1dBm$ ,  $Tx\_Enable = H$ ,  $T_C = 35^\circ C$

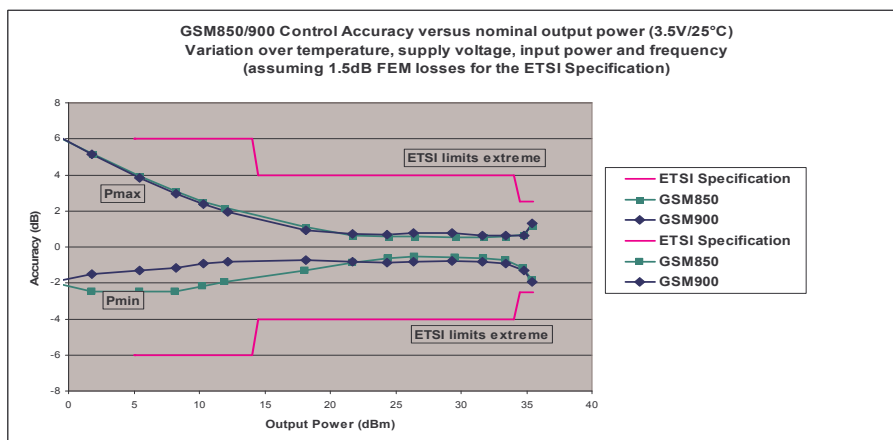
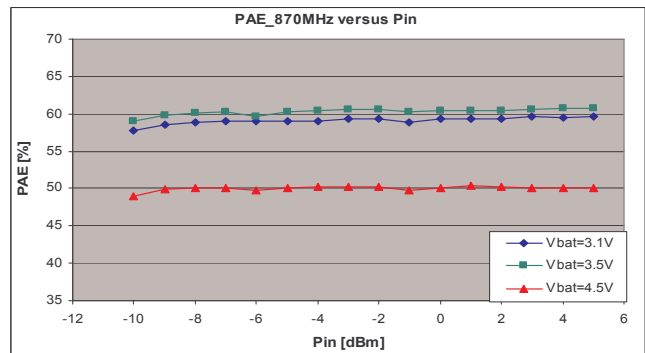
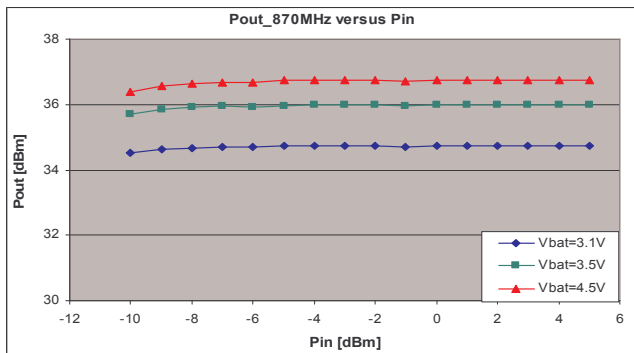
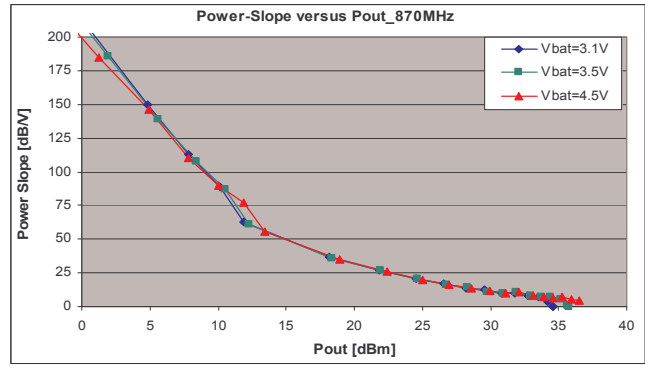
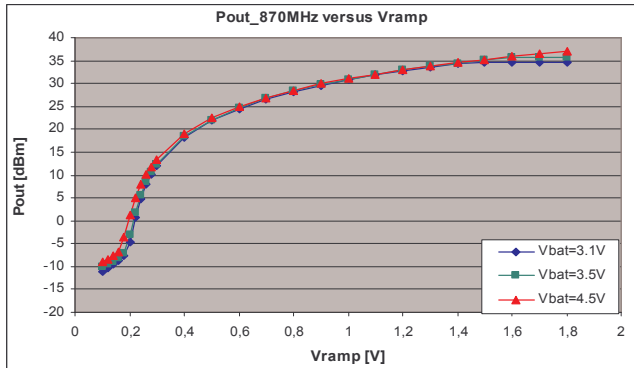
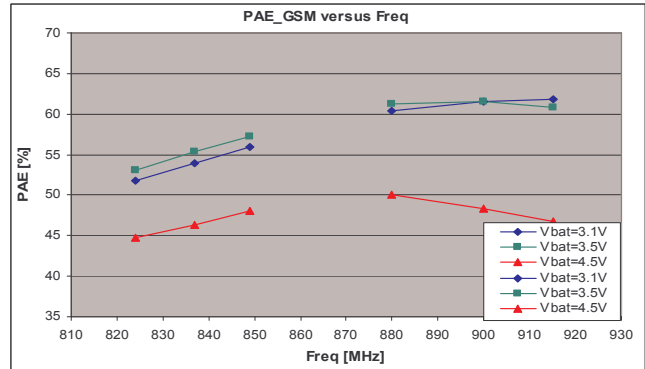
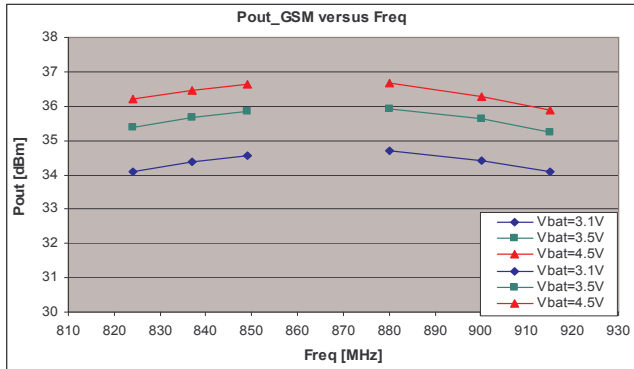

## High Band (DCS 1800/PCS1900) AC Characteristics:

Standard Conditions [unless otherwise stated]:

$V_{CC} = +3.5V$ ,  $V_{RAMP} = 1.7V$ ,  $P_{IN} = -1 \text{ dBm}$ ,  $Tx\_Enable = H$ ,  $T_C = 35^\circ C$

Quantity	Symbol	Condition	Limits			Unit
			Min	Typ	Max	
Frequency Range	$f_{MIN} \dots f_{MAX}$		1710 1850		1785 1910	MHz
Input Power Range	$P_{IN\_MIN}$ $P_{IN\_TYP}$ $P_{IN\_MAX}$		-5	-1	3	dBm
Output Power	$P_{OUT\_MAX}$	Standard Conditions	32	33		dBm
Power degradation		$T_{CMIN} \leq T_C \leq T_{CMAX}$ , $V_{BATT} = 3.1V$ $P_{IN} = P_{IN\_MIN}$	30.5	31.5		dBm
Efficiency (PAE)	$\eta$	$P_{OUT} = P_{OUT\_MAX}$ 1710 – 1785 MHz 1850 – 1910 MHz	48 45	52 50		% %
Input VSWR		$0dBm \leq P_{OUT} \leq P_{OUT\_MAX}$		1.5:1	2.5:1	
Stability (all phases)		$P_{OUT} \leq 32.5dBm$ 12.5%-50% duty cycle No oscillations, All Non-harmonic spurious < -36dBm	8:1			
Ruggedness (all phases)		$P_{OUT} \leq 32.5dBm$ 12.5%-50% duty cycle	10:1			
Harmonics	2fo 3fo	$P_{OUT} \leq 32.5 \text{ dBm}$ , $T_{CMIN} \leq T_C \leq T_{CMAX}$		-10 -15	0 -5	dBm dBm
Harmonics	4fo – 8fo	$P_{OUT} \leq 32.5 \text{ dBm}$ , $T_{CMIN} \leq T_C \leq T_{CMAX}$			-5	dBm
Reverse Harmonic Level	2fo	$P_{OUT} \leq 32.5 \text{ dBm}$ , $T_{CMIN} \leq T_C \leq T_{CMAX}$		-20		dBc
Rx band noise	$P_{noise}$	$P_{OUT} \leq 32.5dBm$ , RBW = 100kHz 1805 MHz $\leq f \leq$ 1880 MHz 1930 MHz $\leq f \leq$ 1990 MHz		-80 -80	-76 -76	dBm dBm
Off Isolation		$P_{IN} \leq P_{IN\_MAX}$ $Tx\_Enable = Low$			-35	dBm

**High Band (DCS 1800/PCS1900) AC Characteristics (cont):**

Slope $P_{OUT}$ $/V_{RAMP}$		1710 MHz $\leq f \leq$ 1785 MHz 1850 MHz $\leq f \leq$ 1910 MHz 10dBm $\leq P_{OUT} \leq P_{OUT\_MAX}$ 0dBm $\leq P_{OUT} \leq$ 10dBm			<100 <150	dB/V dB/V
TX Enable switching time					2	$\mu$ sec
Rise Time	$\tau_R$	Time from $P_{OUT} = 0$ dBm to $P_{OUT} = P_{OUT\_MAX}$			2	$\mu$ sec
Fall Time	$\tau_F$	Time from $P_{OUT} = P_{OUT\_MAX}$ to $P_{OUT} = 0$ dBm			2	$\mu$ sec
ESD Ruggedness		Human Body Model in Application Circuit [100pF/1500 Ohm] All ports	0.5			kV

# High Band (DCS 1800/PCS1900): Typical performance

Standard Conditions [unless otherwise stated] :

$V_{BATT} = +3.5V$ ,  $V_{RAMP} = 1.7V$ ,  $P_{IN} = -1 \text{ dBm}$ ,  $T_X\_Enable = H$ ,  $T_C = 35^\circ C$

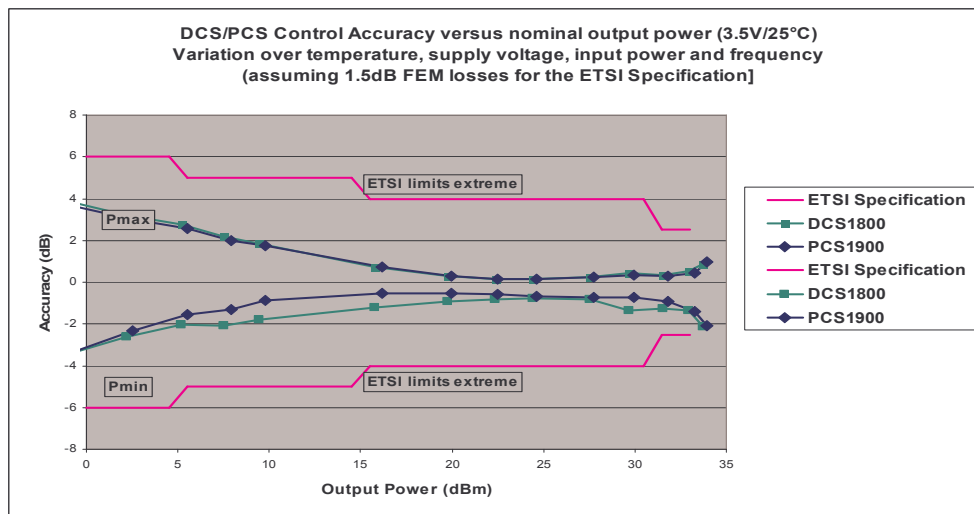
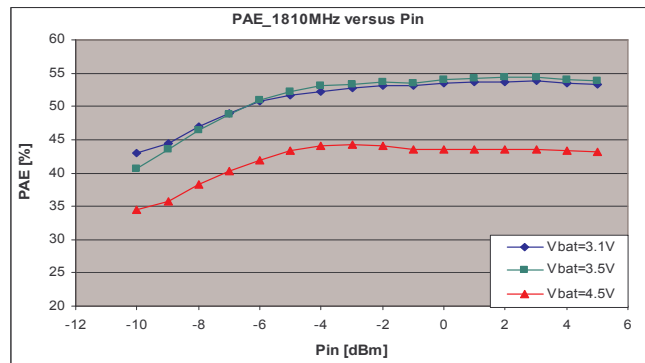
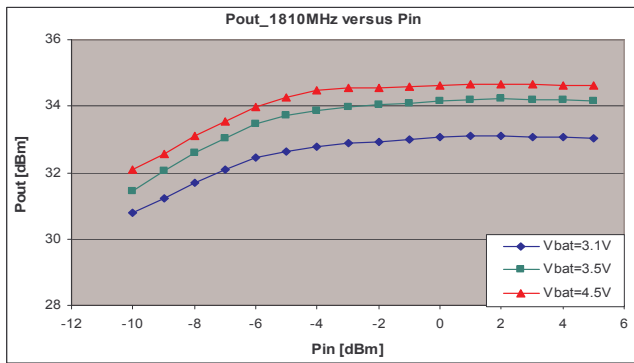
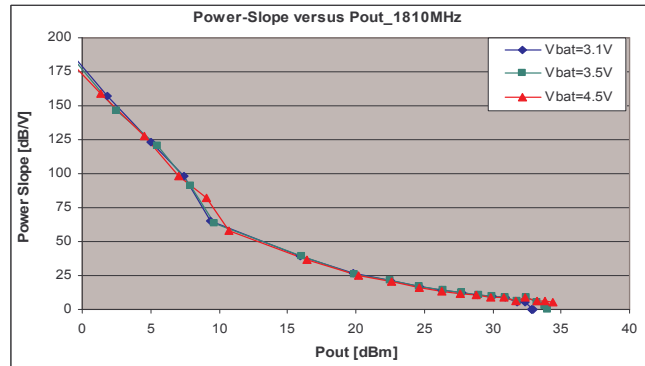
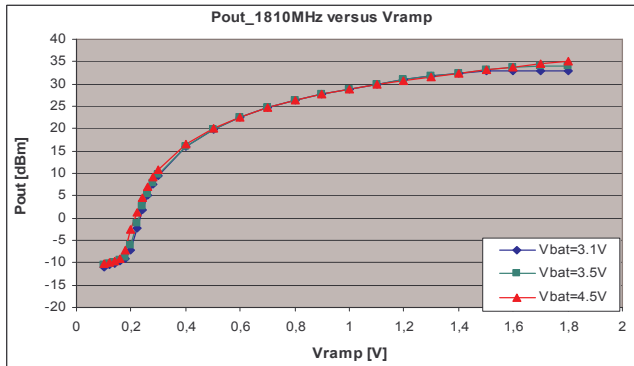
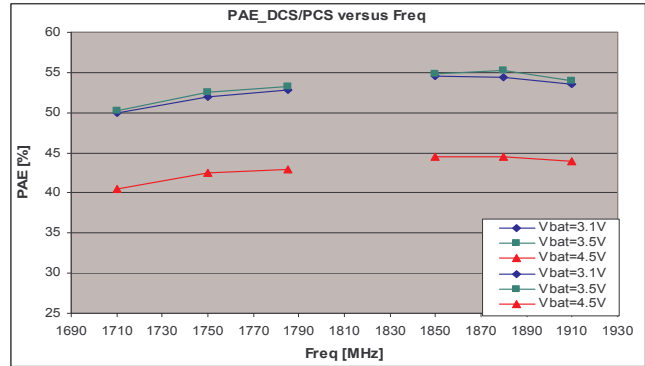
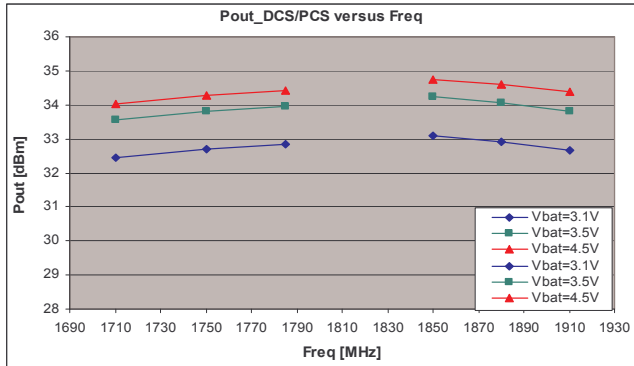



## Pin Out:

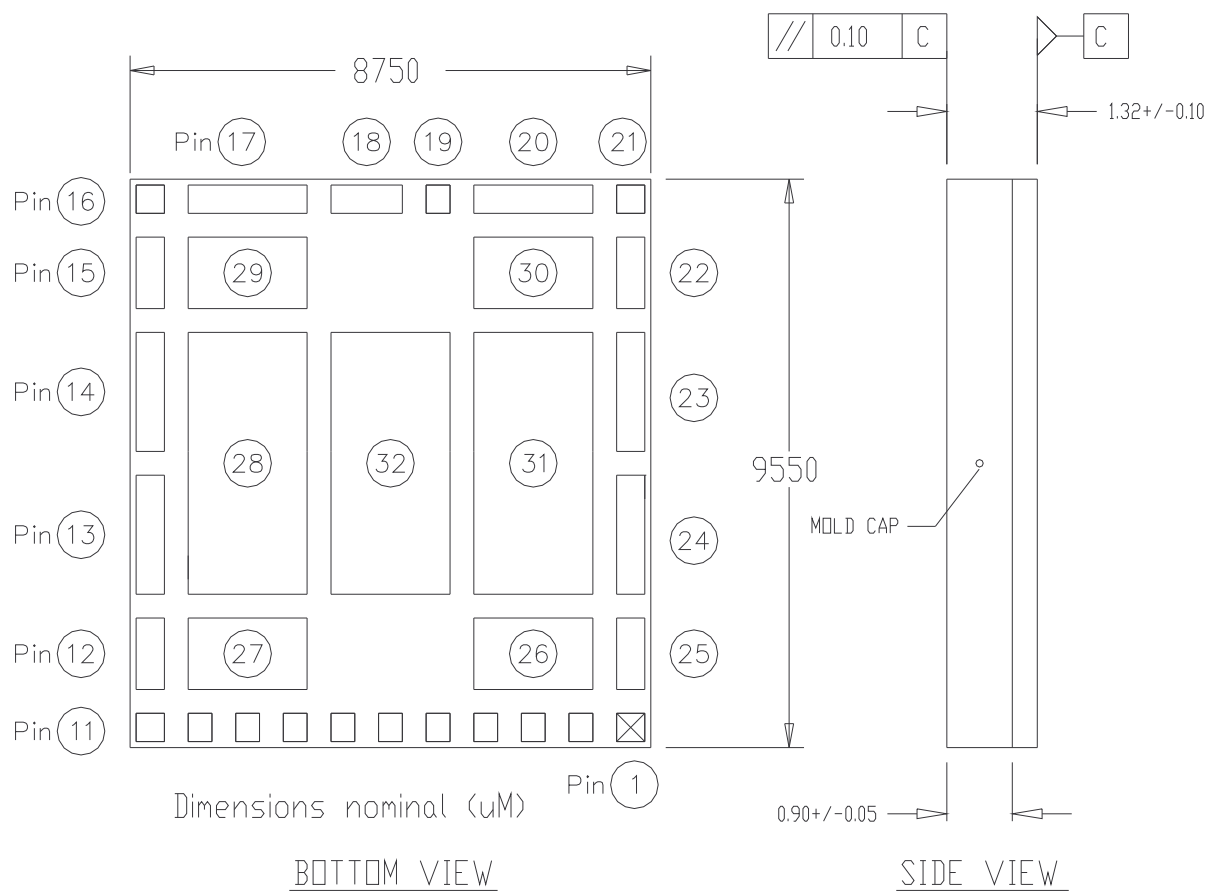

Pin #	Description	Function
1	RFin_DCS	Matched DCS input
2	GND	Ground
3	VBS	Band Select Pin (Low -> GSM mode active; High -> DCS mode active)
4	Tx_Enable	Digital signal. When activated ( $V_{Tx\_Enable} = \text{high}$ ), the PA output power will jump to approx. -10dBm.
5 - 7	Vbatt	Battery supply voltage, typ. 3.1 – 4.2 V, approx. 1.6A
8	Vreg	Regulated voltage provided from the customer board (typ. 2.7V, < 10mA)
9	VRAMP	DAC Control Signal for output power setting, nominal 0.2 .. 1.7 V
10	GND	Ground
11	RFin_GSM	Matched GSM input
12 - 15	GND	Ground
16	RFOut_GSM	Matched GSM output
17 - 18	GND	Ground
19	Vcc	Internal Voltage, for blocking reasons $C_{VCC} \leq 220\text{nF}$
20	GND	Ground
21	RFOut_DCS	Matched DCS output
22 -32	GND	Ground

Schematic:

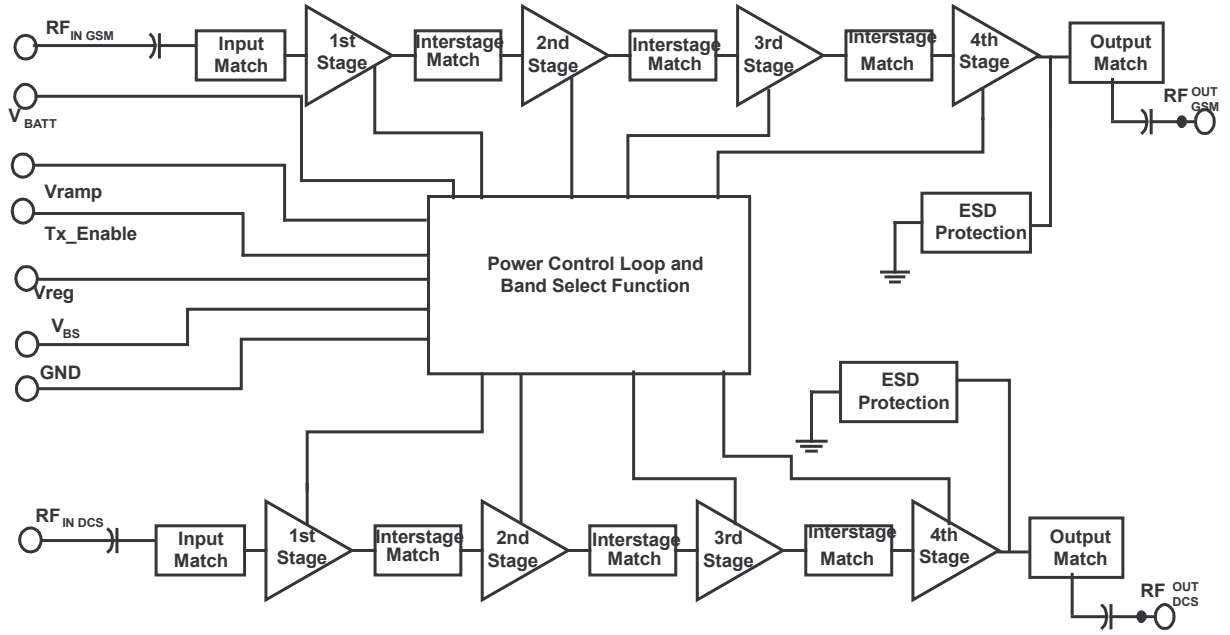

**Recommended Footprint:**

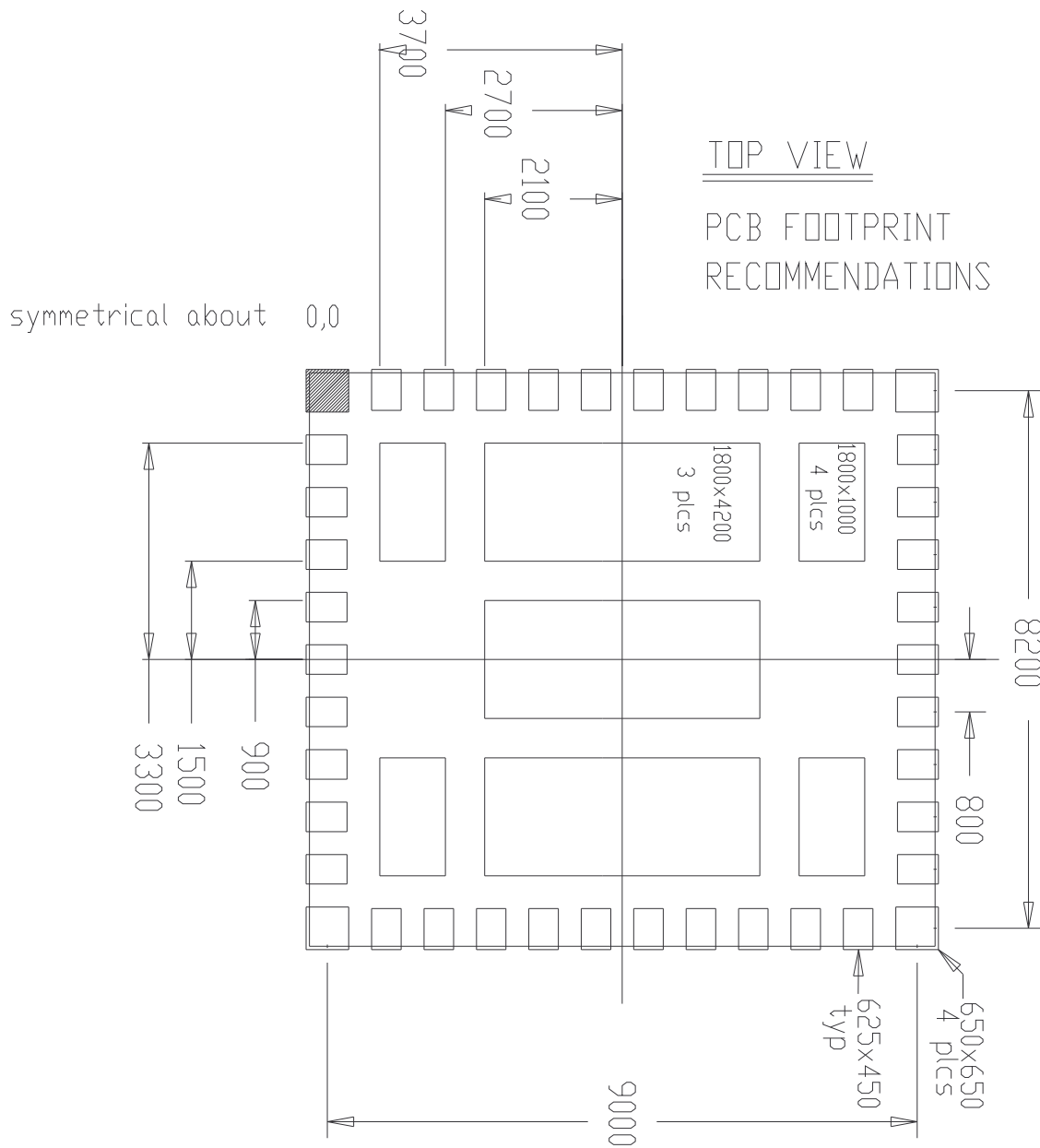

# Pad dimensions

