

KH206

Overdrive-Protected Wideband Op Amp

Features

- -3dB bandwidth of 180MHz
- 70MHz large signal bandwidth (20V_{pp})
- 0.1% settling in 19ns
- Overdrive protected
- Output may be current limited
- Stable without compensation
- 3MΩ input impedance
- Direct replacement for CLC206

Applications

- Fast, precision A/D conversion
- Automatic test equipment
- Input/output amplifiers
- Photodiode, CCD preamps
- High-speed modems, radios
- Line drivers

General Description

The KH206 is a wideband, overdrive-protected operational amplifier designed for applications needing both speed and high drive capability (100mA). Utilizing a well-established current feedback architecture, the KH206 exhibits performance far beyond that of conventional voltage feedback op amps. For example, the KH206 has a bandwidth of 180MHz at a gain of +20 and settles to 0.1% in 19ns. Plus, the KH206 has a combination of important features not found in other high-speed op amps.

The 100mA output current and the large signal bandwidth of 70MHz (20V_{pp}) make the KH206 ideal for applications which involve both high signal amplitudes and heavy loads as in coaxial line driving applications.

Complete overdrive protection has been designed into the KH206. This is critical for applications, such as ATE and instrumentation, which require protection from signal levels high enough to cause saturation of the amplifier. This feature allows the output of the op amp to be protected against short circuits using techniques developed for low-speed op amps. With this capability, even the fastest signal sources can feature effective short circuit protection.

The KH206 is constructed using thin film resistor/bipolar transistor technology, and is available in the following versions:

| | | |
|----------|-----------------|--|
| KH206AI | -25°C to +85°C | 12-pin TO-8 can |
| KH206AK | -55°C to +125°C | 12-pin TO-8 can, features burn-in & hermetic testing |
| KH206AM | -55°C to +125°C | 12-pin TO-8 can, environmentally screened and electrically tested to MIL-STD-883 |
| KH206HXC | -55°C to +125°C | SMD#: 5962-8985801HXC |
| KH206HXA | -55°C to +125°C | SMD#: 5962-8985801HXA |

Small Signal Pulse Response

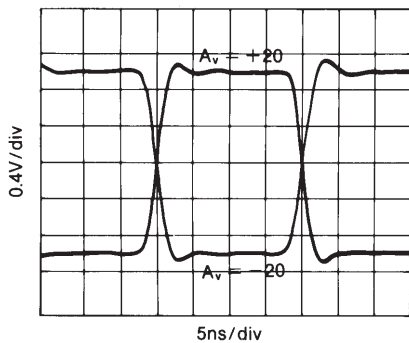

Bottom View

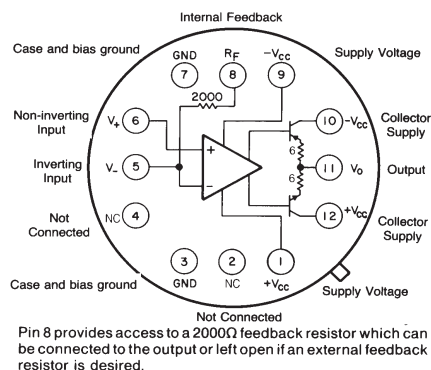

Typical Performance

| parameter | gain setting | | | | | | units |
|-------------------------|--------------|-----|-----|-----|-----|-----|-------|
| | +7 | +20 | +50 | -1 | -20 | -50 | |
| -3dB bandwidth | 220 | 180 | 90 | 220 | 145 | 90 | MHz |
| rise time | 1.6 | 2 | 4 | 1.6 | 2.5 | 4 | ns |
| slew rate | 3.4 | 3.4 | 3.4 | 3.4 | 3.4 | 3.4 | V/ns |
| settling time (to 0.1%) | 22 | 19 | 17 | 20 | 19 | 18 | ns |

KH206 Electrical Characteristics ($A_v = +20, V_{cc} = \pm 15V, R_L = 200\Omega, R_f = 2k\Omega$; unless specified)

| PARAMETERS | CONDITIONS | TYP | MAX & MIN RATINGS | | | | UNITS | SYMBOL |
|--------------------------------------|----------------------|-------------|-------------------|------------|------------|------------------|-------|--------|
| Ambient Temperature | KH206AI | +25°C | -25°C | +25°C | +85°C | | | |
| Ambient Temperature | KH206AK/AM/HXC/HXA | +25°C | -55°C | +25°C | +125°C | | | |
| FREQUENCY DOMAIN RESPONSE | | | | | | | | |
| +3dB bandwidth | $V_{out} < 2V_{pp}$ | 180 | >150 | >150 | >135 | MHz | SSBW | |
| large signal bandwidth | $V_{out} < 20V_{pp}$ | 70 | >54 | >60 | >60 | MHz | FPBW | |
| gain flatness | $V_{out} < 2V_{pp}$ | | | | | | | |
| + peaking | 0.1 to 40MHz | 0 | <0.3 | <0.3 | <0.5 | dB | GFPL | |
| + peaking | >40MHz | 0 | <0.5 | <0.5 | <0.8 | dB | GFPH | |
| + rolloff | at 75MHz | — | <0.7 | <0.7 | <0.7 | dB | GFR | |
| group delay | to 75MHz | 3.0 ± 2 | — | — | — | ns | GD | |
| linear phase deviation | to 75MHz | 0.6 | <2.0 | <1.5 | <2.0 | ° | LPD | |
| TIME DOMAIN RESPONSE | | | | | | | | |
| rise and fall time | 2V step | 2.0 | <2.5 | <2.5 | <2.7 | ns | TRS | |
| | 20V step | 7.0 | <8.5 | <8.5 | <8.5 | ns | TRL | |
| settling time to 0.1% | 10V step, note 2 | 22 | <25 | <25 | <25 | ns | TS | |
| to 0.05% | 10V step, note 2 | 24 | <27 | <27 | <27 | ns | TSP | |
| overshoot | 10V step | 11 | <15 | <15 | <15 | % | OS | |
| slew rate | $20V_{pp}, 100MHz$ | 3.4 | >2.7 | >3.0 | >3.0 | V/ns | SR | |
| DISTORTION AND NOISE RESPONSE | | | | | | | | |
| +2nd harmonic distortion | $2V_{pp}, 20MHz$ | -59 | <-50 | <-50 | <-50 | dBc | HD2 | |
| +3rd harmonic distortion | $2V_{pp}, 20MHz$ | -67 | <-55 | <-55 | <-55 | dBc | HD3 | |
| equivalent input noise | | | | | | | | |
| voltage | >100kHz | 2.1 | <3.0 | <3.0 | <3.5 | nV/\sqrt{Hz} | VN | |
| inverting current | >100kHz | 22 | <30 | <30 | <35 | pA/\sqrt{Hz} | ICN | |
| non-inverting current | >100kHz | 5.0 | <7.0 | <7.0 | <8.0 | pA/\sqrt{Hz} | NCN | |
| noise floor | >100kHz | -157 | <-154 | <-154 | <-153 | dBm(1Hz) | SNF | |
| integrated noise | 1kHz to 150MHz | 39 | <55 | <55 | <61 | uV | INV | |
| noise floor | >5MHz | -157 | <-154 | <-154 | <-153 | dBm(1Hz) | SNF | |
| integrated noise | 5MHz to 150MHz | 39 | <55 | <55 | <61 | uV | INV | |
| STATIC, DC PERFORMANCE | | | | | | | | |
| *input offset voltage | | 3.5 | <8.0 | <8.0 | <11.0 | mV | VIO | |
| average temperature coefficient | | 11 | <25 | <25 | <25 | $\mu V/^\circ C$ | DVIO | |
| *input bias current | non-inverting | 4.0 | <30 | <20 | <20 | uA | IBN | |
| average temperature coefficient | | 20 | <125 | <125 | <125 | $nA/^\circ C$ | DIBN | |
| *input bias current | inverting | 2.0 | <26 | <10 | <30 | uA | IBI | |
| average temperature coefficient | | 40 | <200 | <200 | <200 | $nA/^\circ C$ | DIBI | |
| *power supply rejection ratio | | 65 | >55 | >55 | >55 | dB | PSRR | |
| common mode rejection ratio | | 60 | >50 | >50 | >50 | dB | CMRR | |
| *supply current | no load | 29 | <31 | <31 | <33 | mA | ICC | |
| MISCELLANEOUS PERFORMANCE | | | | | | | | |
| non-inverting input resistance | DC | 3.0 | >1.0 | >1.0 | >1.0 | MΩ | RIN | |
| non-inverting input capacitance | 75MHz | 5.2 | <7.0 | <7.0 | <7.0 | pF | CIN | |
| output impedance | DC | — | <0.1 | <0.1 | <0.1 | Ω | RO | |
| output voltage range | no load | ± 12 | > ± 11 | > ± 11 | > ± 11 | V | VO | |
| internal feedback resistor | | | | | | | | |
| absolute tolerance | | — | — | <0.2 | — | % | RFA | |
| temperature coefficient | | — | — | -100±40 | — | ppm/°C | RFTC | |
| inverting input current self limit | | 3.3 | <4.5 | <4.5 | <4.7 | mA | ICL | |

Min/max ratings are based on product characterization and simulation. Individual parameters are tested as noted. Outgoing quality levels are determined from tested parameters.

Absolute Maximum Ratings

| | |
|--|--------------------------------|
| V_{cc} | $\pm 20V$ |
| I_{out} | $\pm 150mA$ |
| common mode input voltage | $\pm (V_{cc} - 1)V$ |
| differential input voltage | $\pm 3V$ |
| thermal resistance: See thermal model. | |
| junction temperature | +175°C |
| operating temperature | AI: -25°C to +85°C |
| | AK/AM/HXC/HXA: -55°C to +125°C |
| storage temperature | -65°C to +150°C |
| lead temperature (soldering 10s) | +300°C |

Recommended Operating Conditions

| | |
|---------------------------|-----------------------|
| V_{cc} | $\pm 5V$ to $\pm 15V$ |
| I_{out} | $\pm 100mA$ |
| common mode input voltage | $\pm (V_{cc} - 5)V$ |
| gain range: | +7 to +50, -1 to -50 |

note 1: * AI/AK/AM/HXC/HXA 100% tested at 25°C.
 † AK/AM/HXC/HXA 100% tested at +25°C & sample tested at -55°C & +125°C.

† AI sample tested at +25°C.

note 2: Settling time specifications require the use of an external feedback resistor (2Ω).

KH206 Typical Performance Characteristics (T_A = +25°C, A_v = +20, V_{CC} = ±15V, R_L = 200Ω; unless specified)

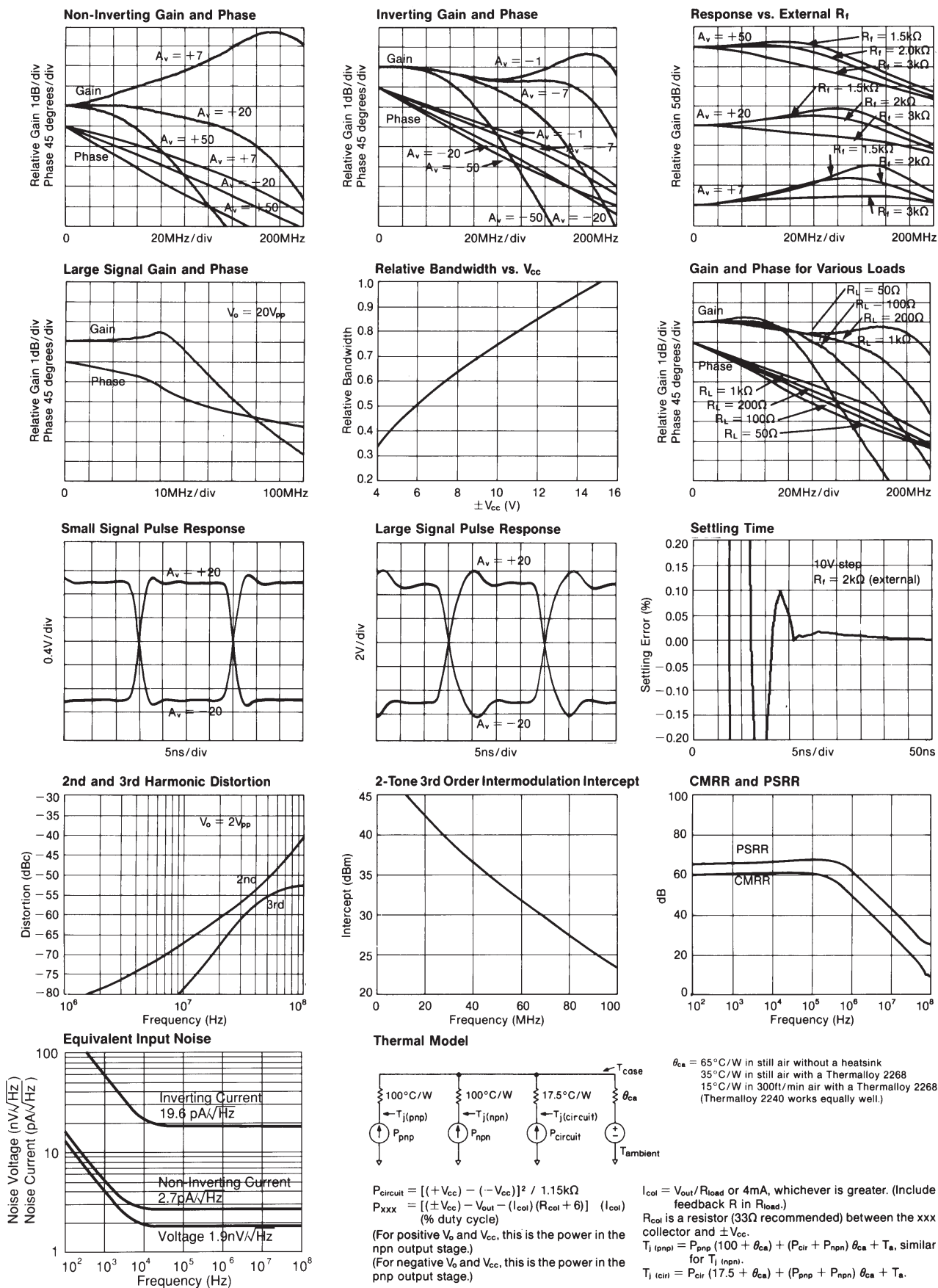

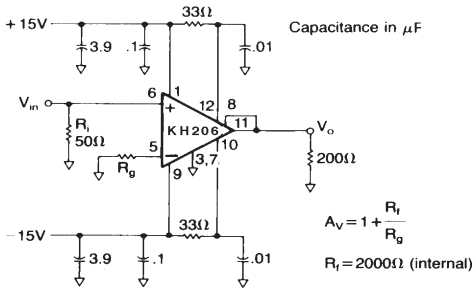

Figure 1: recommended non-inverting gain circuit

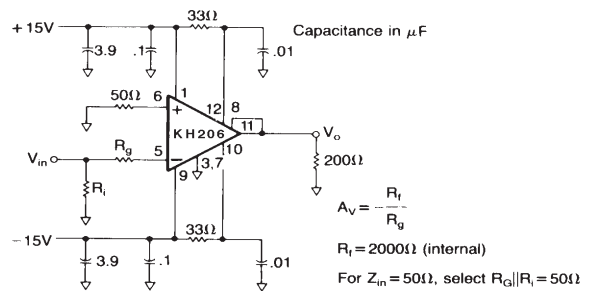

Figure 2: recommended inverting gain circuit

Overdrive Protection

Unlike most other high-speed op amps, the KH206 is not damaged by saturation caused by overdriving input signals (where $V_{in} \times \text{gain} > V_{out}$). The KH206 self limits the current at the inverting input when the output is saturated (see the inverting input current self limit specification); this ensures that the amplifier will not be damaged due to excessive internal currents during overdrive. For protection against input signals which would exceed either the maximum differential or common mode input voltage, the diode clamp circuits below may be used.

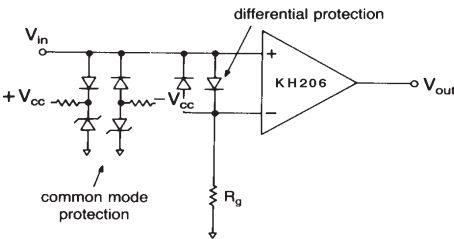

Figure 3: Diode clamp circuits for common mode and differential mode protection

Short Circuit Protection:

Damage caused by short circuits at the output may be prevented by limiting the output current to safe levels. The most simple current limit circuit calls for placing resistors between the output stage collector supplies and the output stage collectors (pins 12 and 10). The value of this resistor is determined by:

$$R_c = \frac{V_c}{I_l} - R_l$$

Where I_l is the desired limit current and R_l is the minimum expected load resistance (0Ω for a short to ground). Bypass capacitors of $0.01\mu\text{F}$ on should be used on the collectors as in Figures 1 and 2.

A more sophisticated current limit circuit which provides a limit current independent of R_l is shown below.

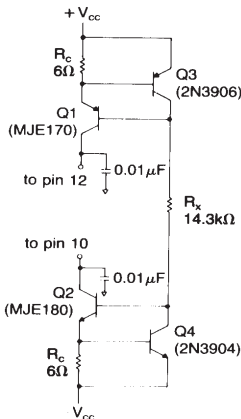

Figure 4: Active current limit circuit (100mA)

With the component values indicated, current limiting occurs at 100mA. For other values of current limit (I_l), select R_c to equal V_{be}/I_l . Where V_{be} is the base to emitter voltage drop of Q3 (or Q4) at a current of $[2V_{cc} - 1.4]/R_x$, where

$R_x \leq [(2V_{cc} - 1.4)/I_l] B_{min}$. Also, B_{min} is the minimum beta of Q1 (or Q2) at a current of I_l . Since the limit current depends on V_{be} , which is temperature dependent, the limit current is likewise temperature dependent.

Controlling Bandwidth and Passband Response

In most applications, a feedback resistor value of $2k\Omega$ will provide optimum performance; nonetheless, some applications may require a resistor of some other value. The response versus R_f plot on the previous page shows how decreasing R_f will increase bandwidth (and frequency response peaking, which may lead to instability). Conversely, large values of feedback resistance tend to roll off the response.

The best settling time performance requires the use of an external feedback resistor (use of the internal resistor results in a 0.1% to 0.2% settling tail). The settling performance may be improved slightly by adding a capacitance of 0.4pF in parallel with the feedback resistor (settling time specifications reflect performance with an external feedback resistor but with no external capacitance).

Noise Analysis

Approximate noise figure can be determined for the KH206 using the equivalent input noise graph on the preceding page and the equations shown below.

Noise figure is for the network inside this box

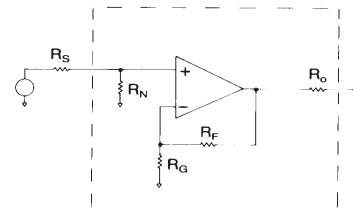

$$F = 10 \log \left[1 + \frac{R_s}{R_N} + \frac{R_s}{4kT} \cdot \left(i_n^2 + \frac{V_n^2}{R_p^2} + \frac{R_f^2 i_i^2}{R_p^2 A_v^2} \right) \right]$$

where $R_p = \frac{R_s R_N}{R_s + R_N}$; $A_v = \frac{R_f}{R_g} + 1$

- $kT = 4.00 \times 10^{-21}$ Joules at 290°K
- V_n is spot noise voltage ($\text{V}/\sqrt{\text{Hz}}$)
- i_n is non-inverting spot noise current ($\text{A}/\sqrt{\text{Hz}}$)
- i_i is inverting spot noise current ($\text{A}/\sqrt{\text{Hz}}$)

Printed Circuit Layout

As with any high frequency device, a good PCB layout will enhance the performance of the KH206. Good ground plane construction and power supply bypassing close to the package are critical to achieving full performance. In the non-inverting configuration, the amplifier is sensitive to stray capacitance to ground at the inverting input. Hence, the inverting node connections should be small with minimal stray capacitance to the ground plane. Shunt capacitance across the feedback resistor should not be used to compensate for this effect.

Evaluation PC boards (part number 730008 for inverting, 730009 for non-inverting) for the KH206 are available.

KH206 Package Dimensions

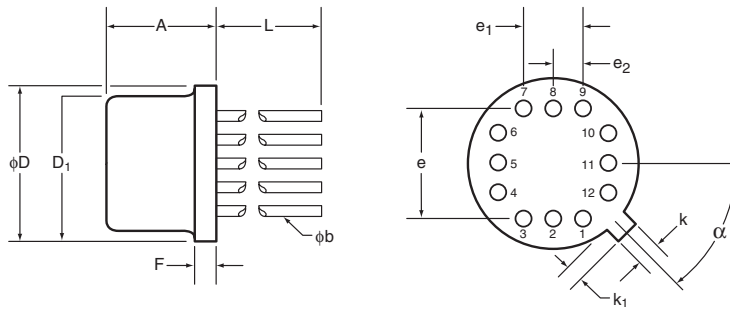

| TO-8 | | | | |
|----------------|-----------|---------|------------|---------|
| SYMBOL | INCHES | | MILIMETERS | |
| | Minimum | Maximum | Minimum | Maximum |
| A | 0.142 | 0.181 | 3.61 | 4.60 |
| ϕb | 0.016 | 0.019 | 0.41 | 0.48 |
| ϕD | 0.595 | 0.605 | 15.11 | 15.37 |
| ϕD_1 | 0.543 | 0.555 | 13.79 | 14.10 |
| e | 0.400 BSC | | 10.16 BSC | |
| e ₁ | 0.200 BSC | | 5.08 BSC | |
| e ₂ | 0.100 BSC | | 2.54 BSC | |
| F | 0.016 | 0.030 | 0.41 | 0.76 |
| k | 0.026 | 0.036 | 0.66 | 0.91 |
| k ₁ | 0.026 | 0.036 | 0.66 | 0.91 |
| L | 0.310 | 0.340 | 7.87 | 8.64 |
| α | 45° BSC | | 45° BSC | |

NOTES:
 Seal: cap weld
 Lead finish: gold per MIL-M-38510
 Package composition:
 Package: metal
 Lid: Type A per MIL-M-38510

DISCLAIMER

FAIRCHILD SEMICONDUCTOR RESERVES THE RIGHT TO MAKE CHANGES WITHOUT FURTHER NOTICES TO ANY PRODUCTS HEREIN TO IMPROVE RELIABILITY, FUNCTION OR DESIGN. FAIRCHILD DOES NOT ASSUME ANY LIABILITY ARISING OUT OF THE APPLICATION OR USE OF ANY PRODUCT OR CIRCUIT DESCRIBED HEREIN; NEITHER DOES IT CONVEY ANY LICENSE UNDER ITS PATENT RIGHTS, NOR THE RIGHTS OF OTHERS.

LIFE SUPPORT POLICY

FAIRCHILD'S PRODUCTS ARE NOT AUTHORIZED FOR USE AS CRITICAL COMPONENTS IN LIFE SUPPORT DEVICES OR SYSTEMS WITHOUT THE EXPRESS WRITTEN APPROVAL OF THE PRESIDENT OF FAIRCHILD SEMICONDUCTOR CORPORATION. As used herein:

- Life support devices or systems are devices or systems which, (a) are intended for surgical implant into the body, or (b) support or sustain life, and (c) whose failure to perform when properly used in accordance with instructions for use provided in the labeling, can be reasonably expected to result in a significant injury of the user.
- A critical component in any component of a life support device or system whose failure to perform can be reasonably expected to cause the failure of the life support device or system, or to affect its safety or effectiveness.