



## Dual N-Channel Enhancement Mode Field Effect Transistor

PRODUCT SUMMARY		
V <sub>DSS</sub>	I <sub>D</sub>	R <sub>DS(ON)</sub> (mΩ) Max
30V	4A	50 @ V <sub>GS</sub> = 10V
		65 @ V <sub>GS</sub> = 4.5V

### FEATURES

- Super high dense cell design for low R<sub>DS(ON)</sub>.
- Rugged and reliable.
- SOT-26 package.

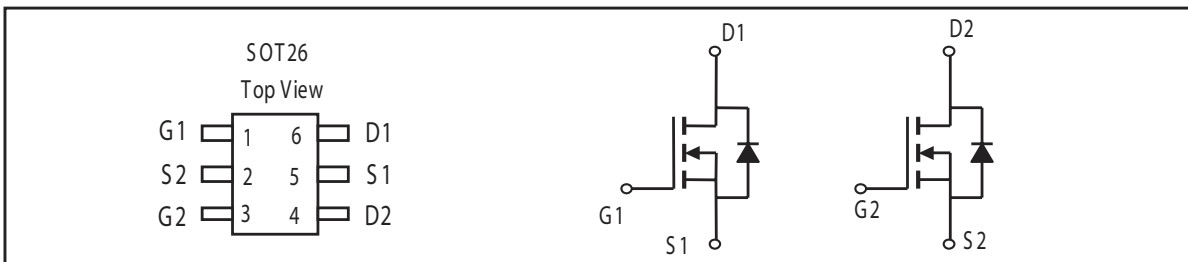

### ABSOLUTE MAXIMUM RATINGS (T<sub>A</sub>=25 °C unless otherwise noted)

Parameter	Symbol	Limit	Unit
Drain-Source Voltage	V <sub>DS</sub>	30	V
Gate-Source Voltage	V <sub>GS</sub>	± 20	V
Drain Current-Continuous @ T <sub>J</sub> =25 °C -Pulsed <sup>b</sup>	I <sub>D</sub>	4	A
	I <sub>DM</sub>	16	A
Drain-Source Diode Forward Current	I <sub>S</sub>	1.25	A
Maximum Power Dissipation <sup>a</sup>	P <sub>D</sub>	1.25	W
Operating Junction and Storage Temperature Range	T <sub>J</sub> , T <sub>STG</sub>	-55 to 150	°C

### THERMAL CHARACTERISTICS

Thermal Resistance, Junction-to-Ambient <sup>a</sup>	R <sub>thJA</sub>	100	°C/W
--	-------------------	-----	------

# STS 3623

ELECTRICAL CHARACTERISTICS ( $T_A = 25\text{ }^\circ\text{C}$  unless otherwise noted)

Parameter	Symbol	Condition	Min	Typ <sup>c</sup>	Max	Unit
<b>OFF CHARACTERISTICS</b>						
Drain-Source Breakdown Voltage	$BV_{DSS}$	$V_{GS} = 0V, I_D = 250\mu A$	30			V
Zero Gate Voltage Drain Current	$I_{DSS}$	$V_{DS} = 24V, V_{GS} = 0V$			1	$\mu A$
Gate-Body Leakage	$I_{GSS}$	$V_{GS} = \pm 20V, V_{DS} = 0V$			$\pm 100$	nA
<b>ON CHARACTERISTICS<sup>b</sup></b>						
Gate Threshold Voltage	$V_{GS(th)}$	$V_{DS} = V_{GS}, I_D = 250\mu A$	1	1.6	3	V
Drain-Source On-State Resistance	$R_{DS(ON)}$	$V_{GS} = 10V, I_D = 3A$		40	50	m-ohm
		$V_{GS} = 4.5V, I_D = 2A$		50	65	m-ohm
On-State Drain Current	$I_{D(ON)}$	$V_{DS} = 5V, V_{GS} = 4.5V$	10			A
Forward Transconductance	$g_{FS}$	$V_{DS} = 5V, I_D = 3A$		7		S
<b>DYNAMIC CHARACTERISTICS<sup>c</sup></b>						
Input Capacitance	$C_{ISS}$	$V_{DS} = 15V, V_{GS} = 0V$ $f = 1.0MHz$		280		pF
Output Capacitance	$C_{OSS}$			70		pF
Reverse Transfer Capacitance	$C_{RSS}$			38		pF
<b>SWITCHING CHARACTERISTICS<sup>c</sup></b>						
Turn-On Delay Time	$t_{D(ON)}$	$V_{DD} = 15V,$ $I_D = 1A,$ $V_{GS} = 10V,$ $R_{GEN} = 6\text{ ohm}$		6		ns
Rise Time	$t_r$			5		ns
Turn-Off Delay Time	$t_{D(OFF)}$			18		ns
Fall Time	$t_f$			6		ns
Total Gate Charge	$Q_g$	$V_{DS} = 15V, I_D = 3A,$ $V_{GS} = 10V$		5.9		nC
Gate-Source Charge	$Q_{gs}$			0.7		nC
Gate-Drain Charge	$Q_{gd}$			1.4		nC

# STS 3623

## ELECTRICAL CHARACTERISTICS ( $T_A=25^{\circ}\text{C}$ unless otherwise noted)

Parameter	Symbol	Condition	Min	Typ <sup>c</sup>	Max	Unit
DRAIN-SOURCE DIODE CHARACTERISTICS <sup>b</sup>						
Diode Forward Voltage	$V_{SD}$	$V_{GS} = 0\text{V}, I_S = 1.25\text{A}$		0.81	1.15	V

### Notes

- a. Surface Mounted on FR4 Board,  $t \leq 10\text{sec}$ .
- b. Pulse Test: Pulse Width  $\leq 300\mu\text{s}$ , Duty Cycle  $\leq 2\%$ .
- c. Guaranteed by design, not subject to production testing.

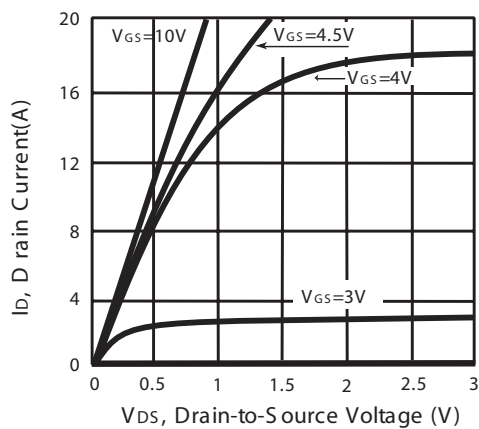

Figure 1. Output Characteristics

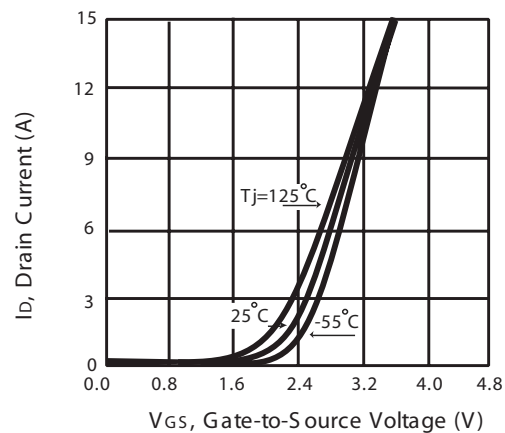

Figure 2. Transfer Characteristics

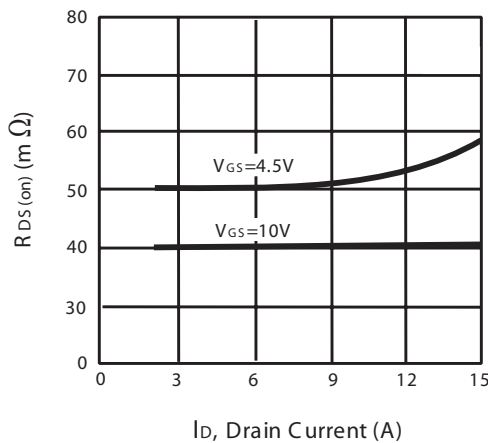

Figure 3. On-Resistance vs. Drain Current and Gate Voltage

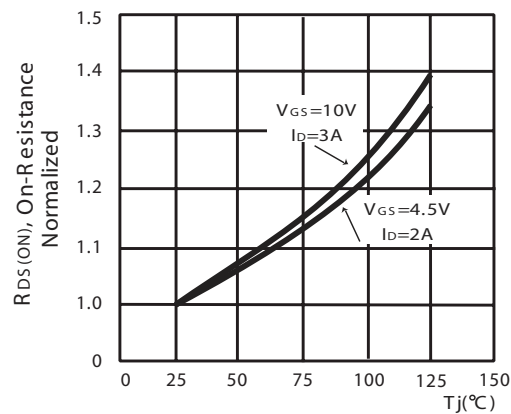

Figure 4. On-Resistance Variation with Temperature

# STS 3623

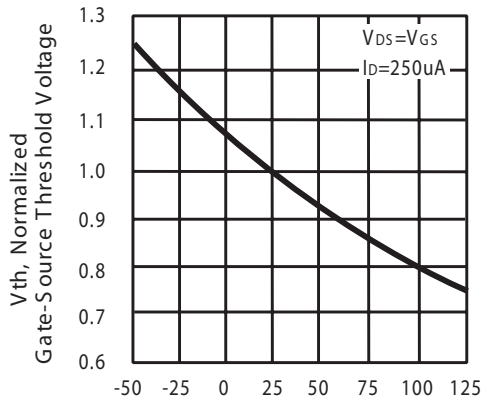

Figure 5. Gate Threshold Variation with Temperature

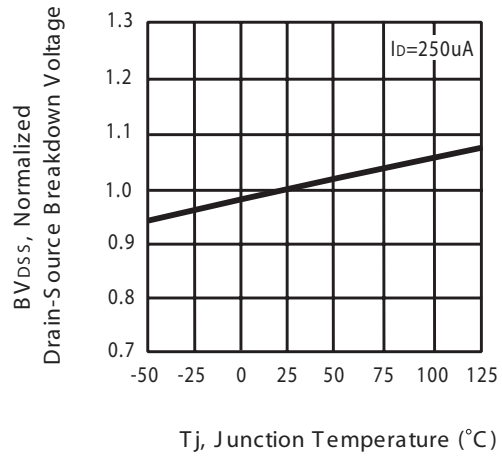

Figure 6. Breakdown Voltage Variation with Temperature

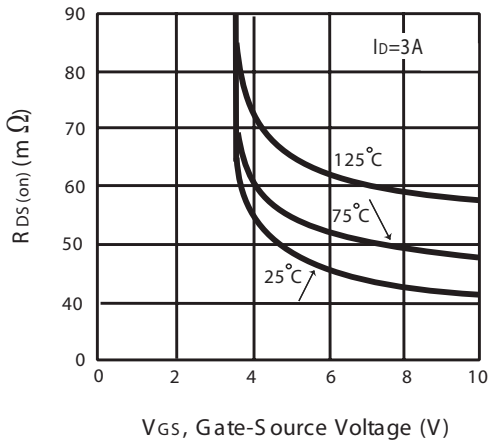

Figure 7. On-Resistance vs. Gate-Source Voltage

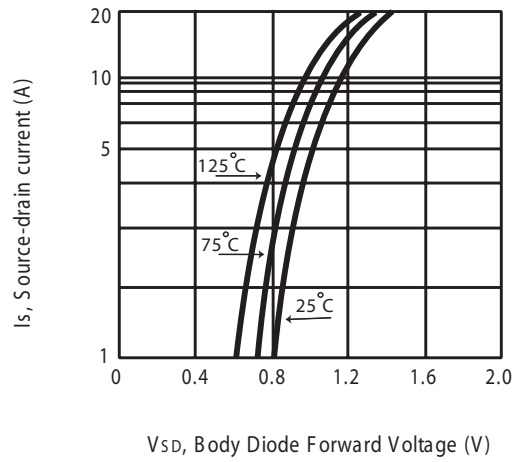

Figure 8. Body Diode Forward Voltage Variation with Source Current

# STS 3623

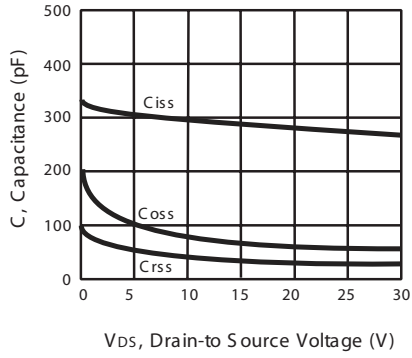

Figure 9. Capacitance

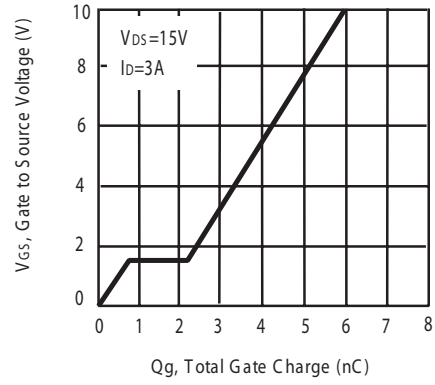

Figure 10. Gate Charge

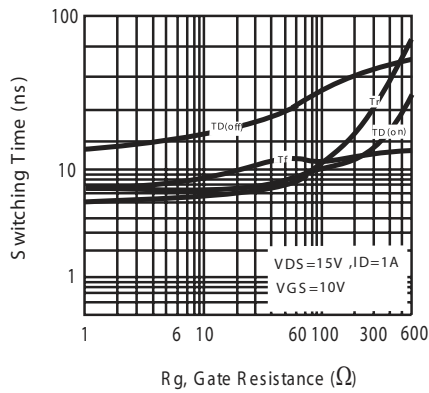

Figure 11. switching characteristics

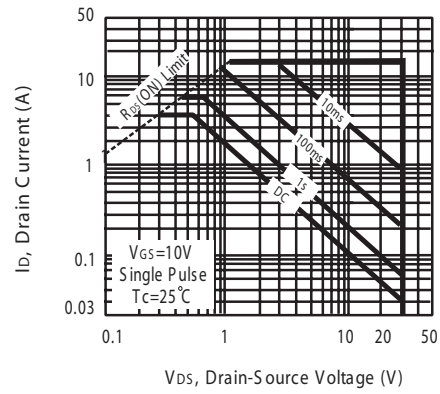

Figure 12. Maximum Safe Operating Area

# STS 3623

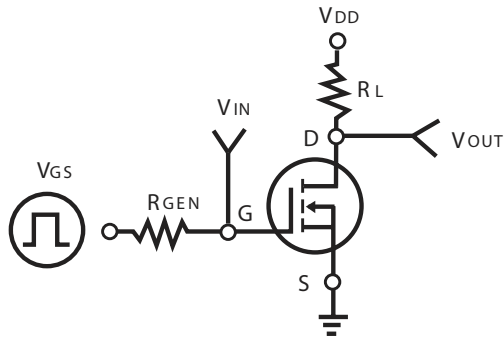

Figure 11. Switching Test Circuit

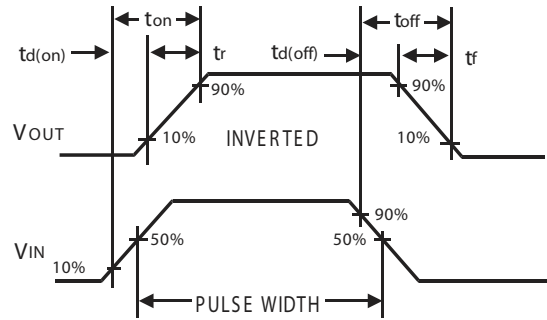
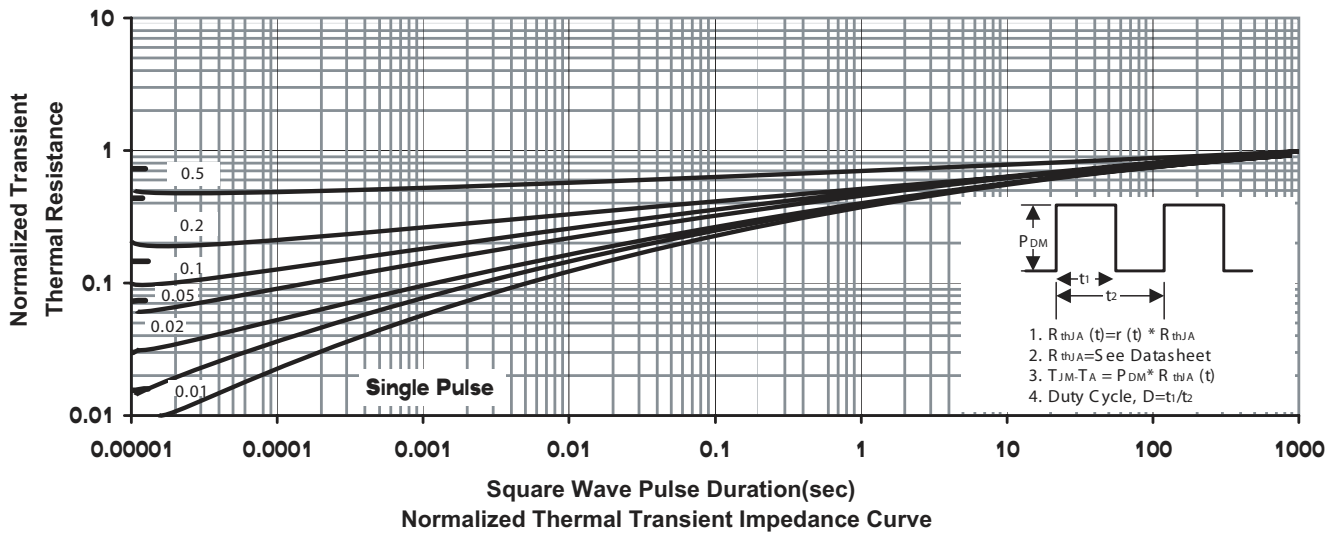
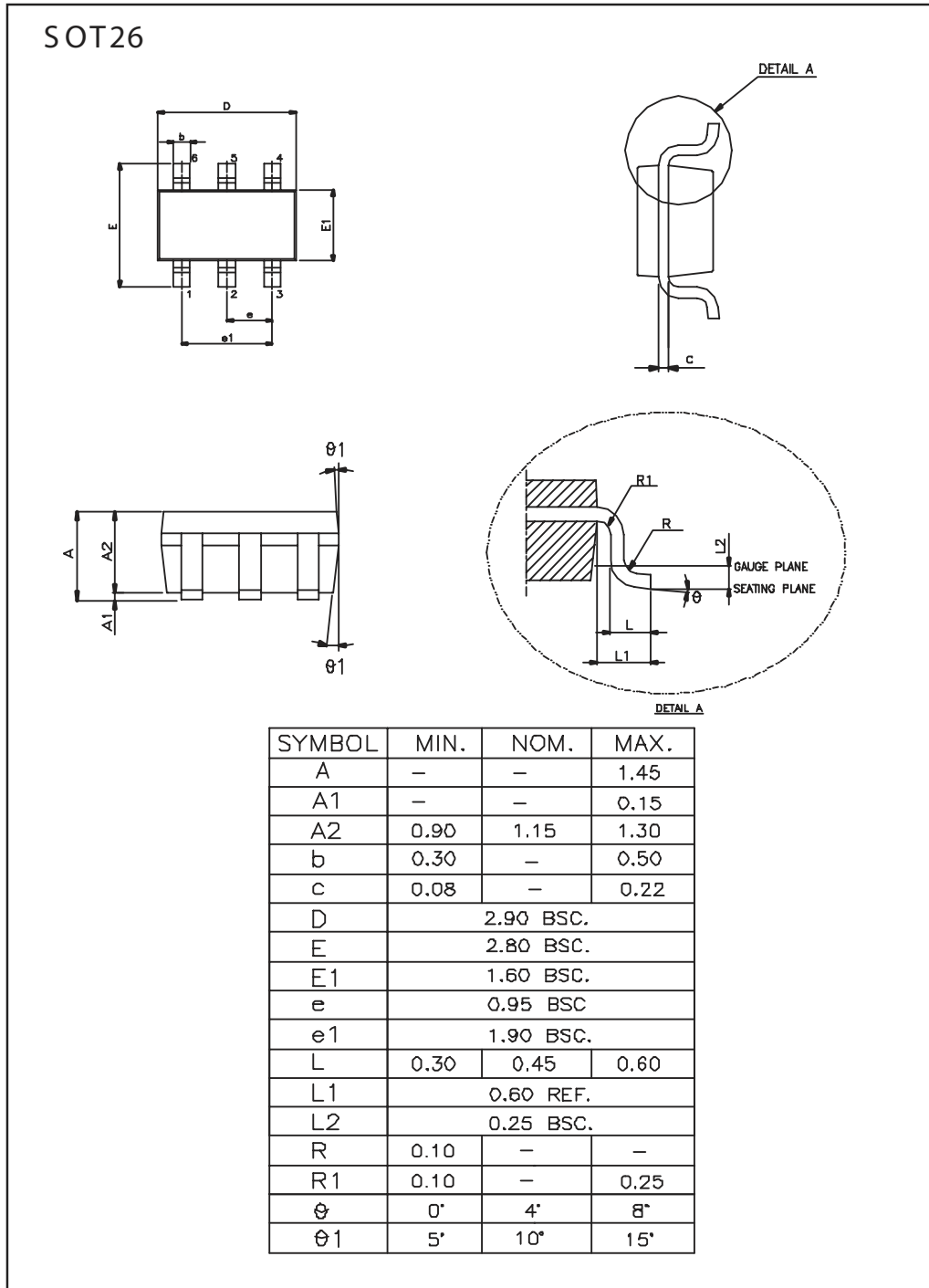

Figure 12. Switching Waveforms



# STS 3623

## PACKAGE OUTLINE DIMENSIONS



# STS 3623

## SOT 26 Tape and Reel Data

### SOT 26 Carrier Tape

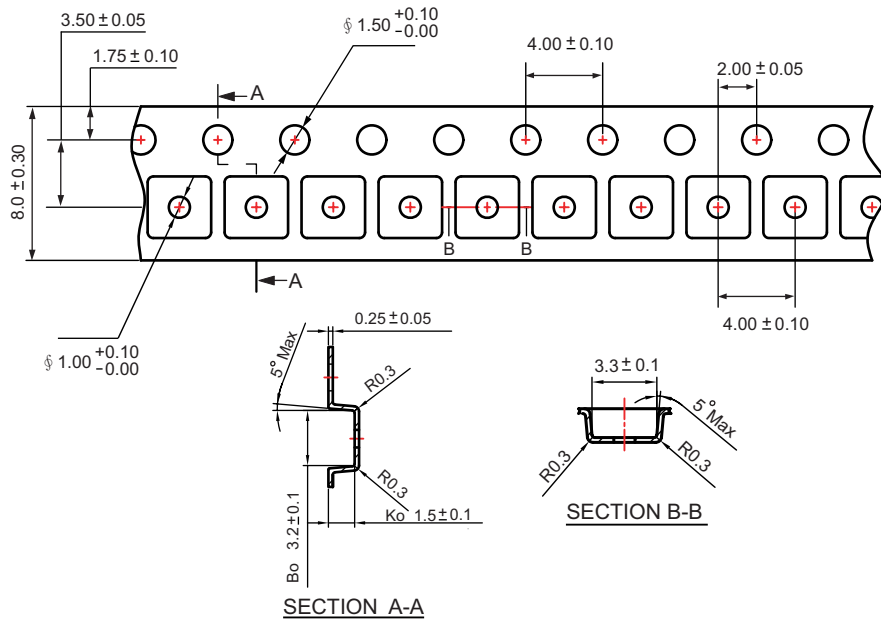

### SOT 26 Reel

