



## P-Channel Enhancement Mode MOSFET

PRODUCT SUMMARY		
V <sub>DSS</sub>	I <sub>D</sub>	R <sub>DS(ON)</sub> (mΩ) Max
-30V	-3A	65 @ V <sub>GS</sub> = -10V
		80 @ V <sub>GS</sub> = -4.5V

### FEATURES

- Super high dense cell design for low R<sub>DS(ON)</sub>.
- Rugged and reliable.
- SOT-23 Package.

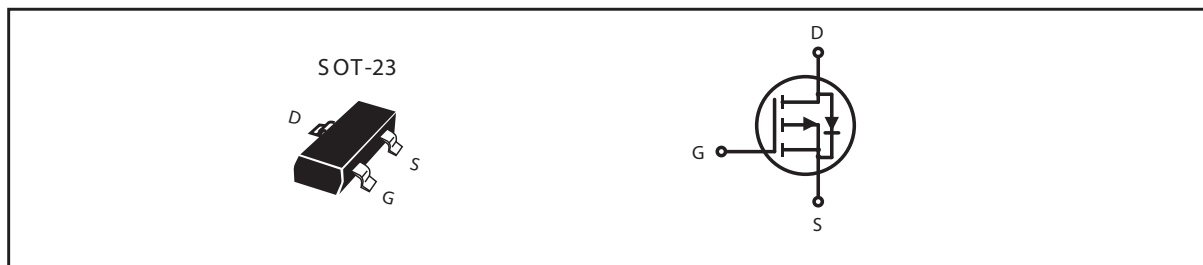

### ABSOLUTE MAXIMUM RATINGS (T<sub>A</sub>=25°C unless otherwise noted)

Parameter	Symbol	Limit	Unit
Drain-Source Voltage	V <sub>DS</sub>	-30	V
Gate-Source Voltage	V <sub>GS</sub>	±20	V
Drain Current-Continuous @ T <sub>J</sub> =25°C -Pulsed <sup>b</sup>	I <sub>D</sub>	-3	A
	I <sub>DM</sub>	-10	A
Drain-Source Diode Forward Current <sup>a</sup>	I <sub>S</sub>	-1.25	A
Maximum Power Dissipation <sup>a</sup>	P <sub>D</sub>	1.25	W
Operating Junction and Storage Temperature Range	T <sub>J</sub> , T <sub>STG</sub>	-55 to 150	°C

### THERMAL CHARACTERISTICS

Thermal Resistance, Junction-to-Ambient <sup>a</sup>	R <sub>θJA</sub>	100	°C/W
--	------------------	-----	------

# STS 3403

ELECTRICAL CHARACTERISTICS ( $T_A = 25^\circ\text{C}$  unless otherwise noted)

Parameter	Symbol	Condition	Min	Typ <sup>c</sup>	Max	Unit
<b>OFF CHARACTERISTICS</b>						
Drain-Source Breakdown Voltage	$BV_{DSS}$	$V_{GS} = 0V, I_D = -250\mu A$	-30			V
Zero Gate Voltage Drain Current	$I_{DSS}$	$V_{DS} = -24V, V_{GS} = 0V$			-1	$\mu A$
Gate-Body Leakage	$I_{GSS}$	$V_{GS} = \pm 20V, V_{DS} = 0V$			$\pm 100$	nA
<b>ON CHARACTERISTICS<sup>b</sup></b>						
Gate Threshold Voltage	$V_{GS(th)}$	$V_{DS} = V_{GS}, I_D = -250\mu A$	-1	-1.5	-3	V
Drain-Source On-State Resistance	$R_{DS(ON)}$	$V_{GS} = -10V, I_D = -3A$		44	65	m-ohm
		$V_{GS} = -4.5V, I_D = -1A$		60	80	m-ohm
On-State Drain Current	$I_{D(ON)}$	$V_{DS} = -5V, V_{GS} = -10V$	5			A
Forward Transconductance	$g_{FS}$	$V_{DS} = -5V, I_D = -3A$		7		S
<b>DYNAMIC CHARACTERISTICS<sup>c</sup></b>						
Input Capacitance	$C_{ISS}$	$V_{DS} = -10V, V_{GS} = 0V$ $f = 1.0MHz$		870		pF
Output Capacitance	$C_{OSS}$			290		pF
Reverse Transfer Capacitance	$C_{RSS}$			180		pF
<b>SWITCHING CHARACTERISTICS<sup>c</sup></b>						
Turn-On Delay Time	$t_{D(ON)}$	$V_{DD} = -10V,$ $I_D = -1A,$ $V_{GEN} = -4.5V,$ $R_{GEN} = 6\text{ ohm}$		27		ns
Rise Time	$t_r$			67		ns
Turn-Off Delay Time	$t_{D(OFF)}$			35		ns
Fall Time	$t_f$			26		ns
Total Gate Charge	$Q_g$	$V_{DS} = -10V, I_D = -3A, V_{GS} = -4.5V$		7.7		nC
Gate-Source Charge	$Q_{gs}$	$V_{DS} = -10V, I_D = -3A,$ $V_{GS} = -4.5V$		1.2		nC
Gate-Drain Charge	$Q_{gd}$			4		nC

# STS 3403

## ELECTRICAL CHARACTERISTICS ( $T_A=25^{\circ}\text{C}$ unless otherwise noted)

Parameter	Symbol	Condition	Min	Typ <sup>c</sup>	Max	Unit
<b>DRAIN-SOURCE DIODE CHARACTERISTICS<sup>b</sup></b>						
Diode Forward Voltage	$V_{SD}$	$V_{GS} = 0\text{V}, I_s = -1.25\text{A}$		-0.78	-1.2	V

### Notes

- a. Surface Mounted on FR4 Board,  $t \leq 10\text{sec}$ .
- b. Pulse Test: Pulse Width  $\leq 300\mu\text{s}$ , Duty Cycle  $\leq 2\%$ .
- c. Guaranteed by design, not subject to production testing.

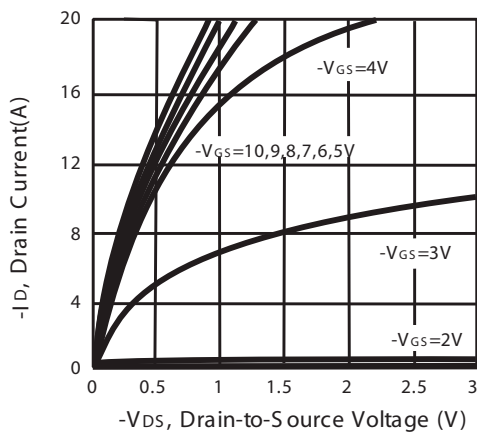

Figure 1. Output Characteristics

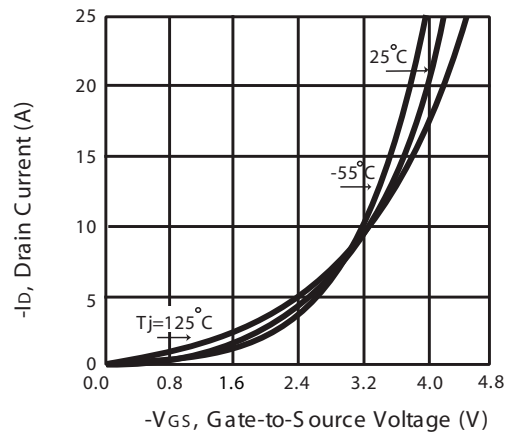

Figure 2. Transfer Characteristics

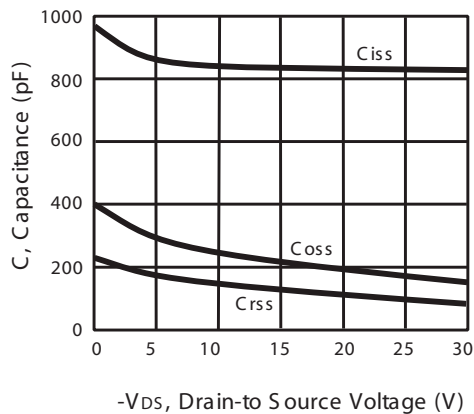

Figure 3. Capacitance

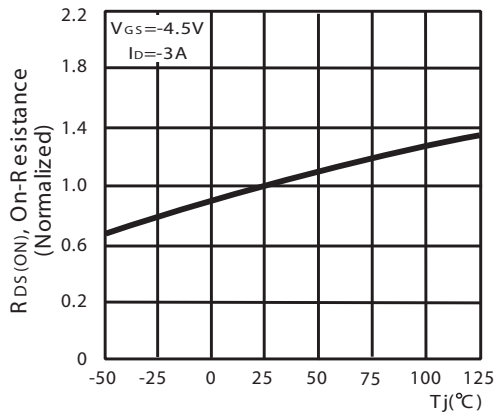
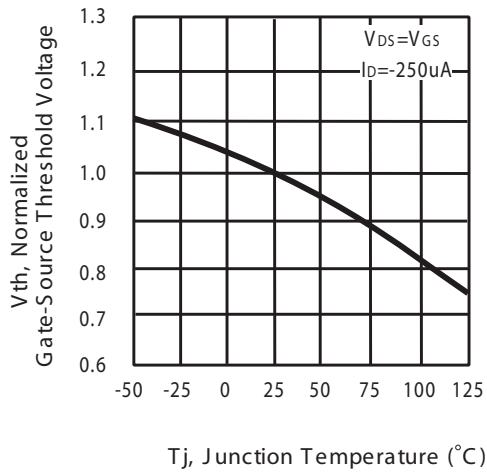

Figure 4. On-Resistance Variation with Temperature

# STS 3403



with Temperature

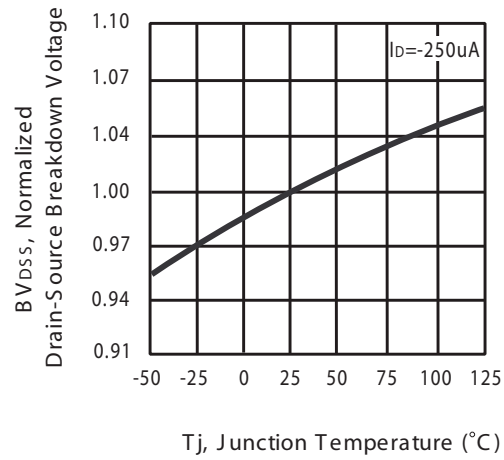

Figure 6. Breakdown Voltage Variation with Temperature

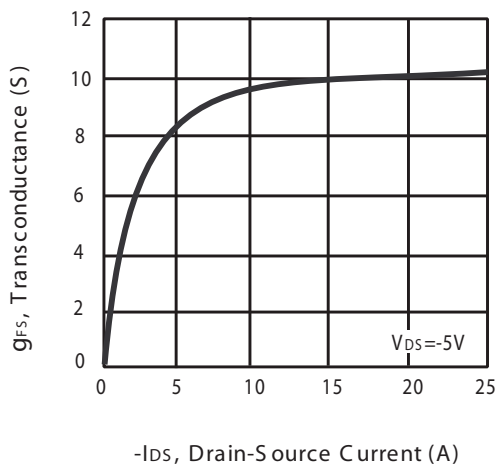

Figure 7. Transconductance Variation with Drain Current

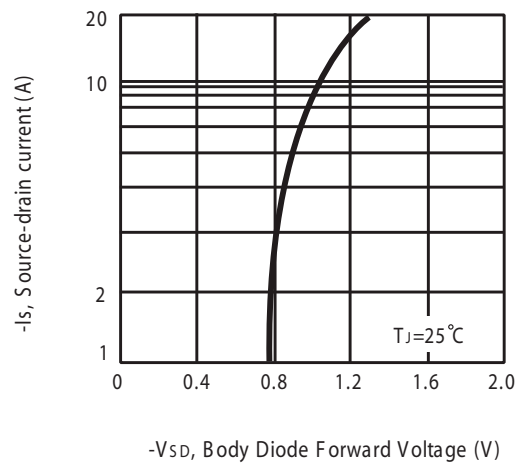

Figure 8. Body Diode Forward Voltage Variation with Source Current

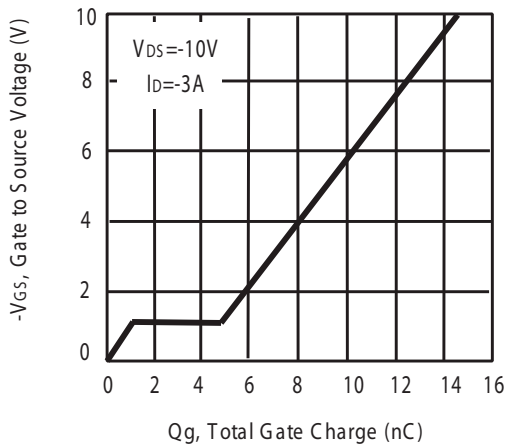

Figure 9. Gate Charge

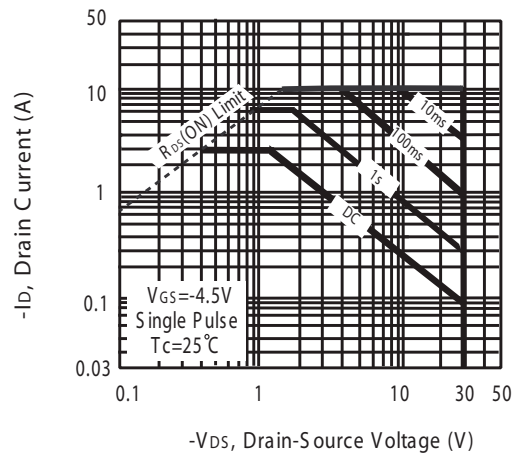

Figure 10. Maximum Safe Operating Area

# STS 3403

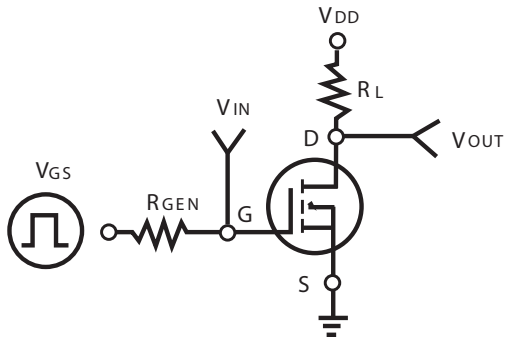

Figure 11. Switching Test Circuit

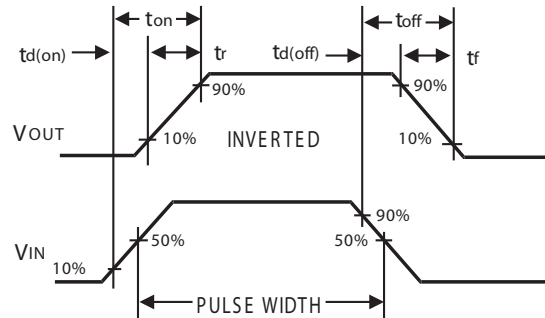
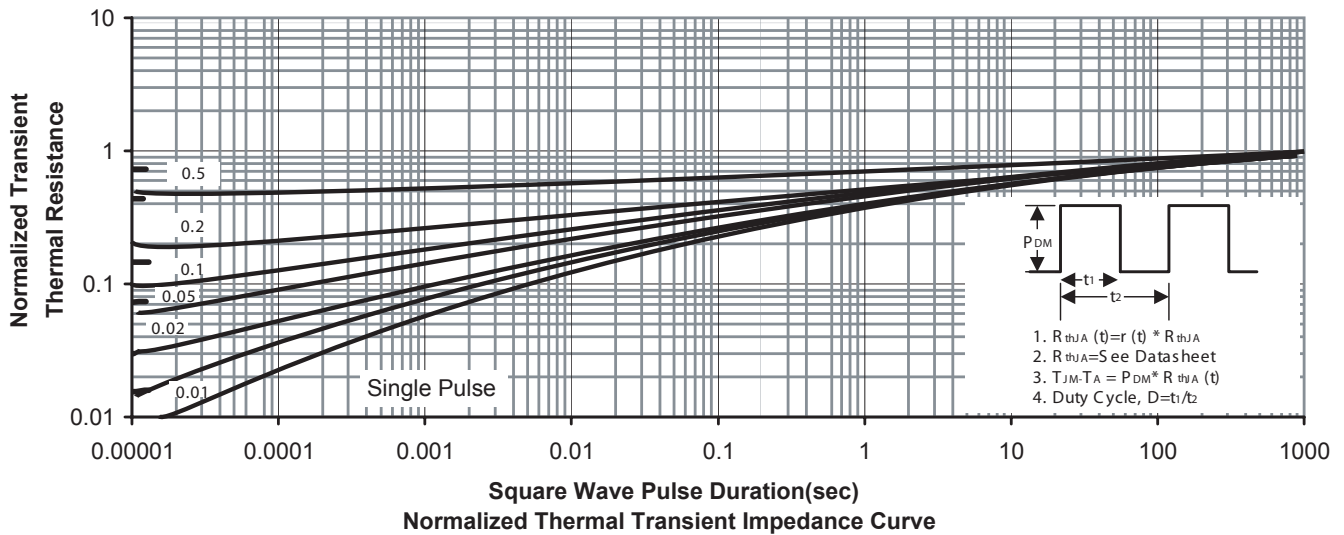

Figure 12. S switching Waveforms



# STS 3403

## PACKAGE OUTLINE DIMENSIONS

### SOT-23

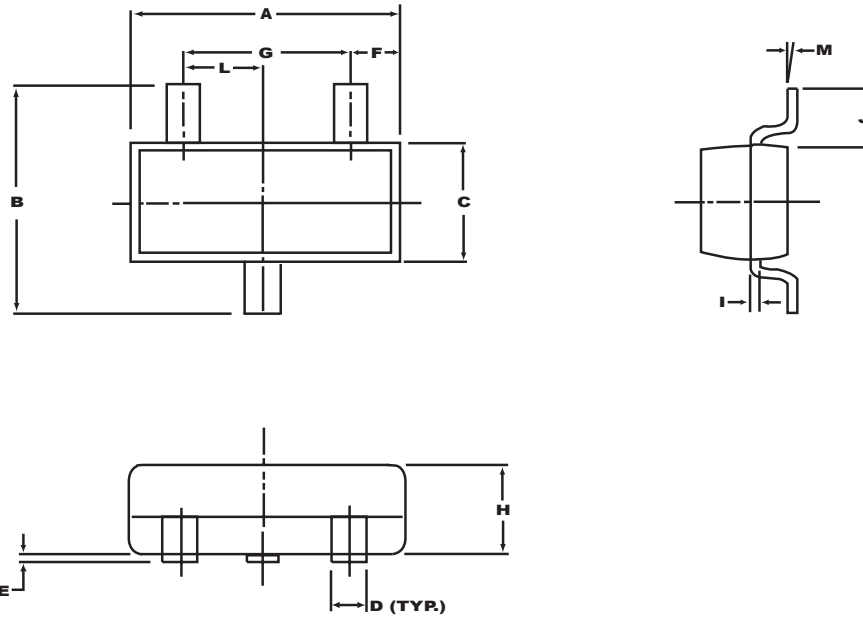

SYMBOLS	MILLIMETERS		INCHES	
	MIN	MAX	MIN	MAX
A	2.70	3.10	0.106	0.122
B	2.40	2.80	0.094	0.110
C	1.40	1.60	0.055	0.063
D	0.35	0.50	0.014	0.020
E	0	0.10	0	0.004
F	0.45	0.55	0.018	0.022
G	1.90 REF.		0.075 REF.	
H	1.00	1.30	0.039	0.051
I	0.10	0.20	0.004	0.008
J	0.40	-	0.016	-
L	0.45	1.15	0.033	0.045
M	0°	10°	0°	10°

# STS 3403

## SOT-23 Tape and Reel Data

### SOT-23 Carrier Tape

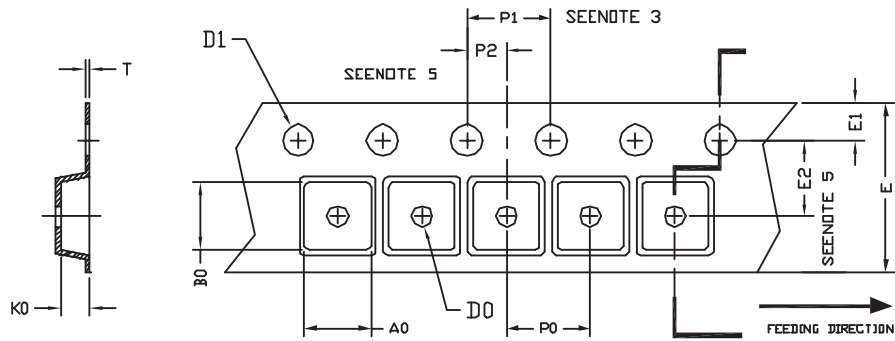

UNIT:mm

PACKAGE	A0	B0	K0	D0	D1	E	E1	E2	P0	P1	P2	T
SOT-23	3.20 ±0.10	3.00 ±0.10	1.33 ±0.10	1.00 ±0.25	1.50 ±0.10	8.00 +0.30 -0.10	1.75 ±0.10	3.50 ±0.05	4.00 ±0.10	4.00 ±0.10	2.00 ±0.05	0.20 ±0.02

### SOT-23 Reel

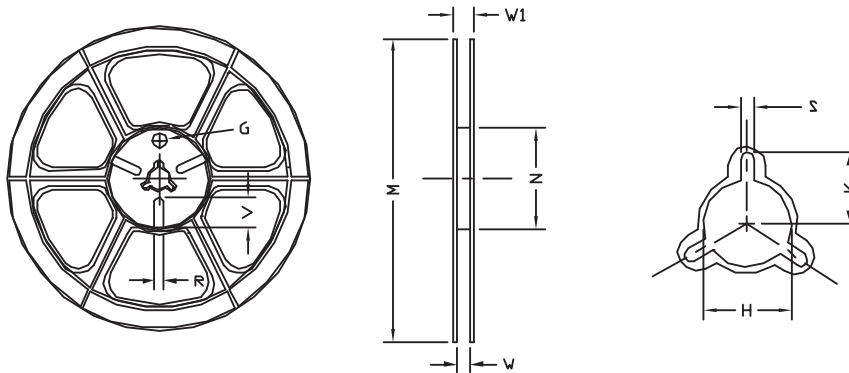

UNIT:mm

TAPE SIZE	REEL SIZE	M	N	W	W1	H	K	S	G	R	V
8mm	178	178 ±1	60 ±1	9.00 ±0.5	12.00 ±0.5	13.5 ±0.5	10.5	2.00 ±0.5	10.0	5.00	18.00