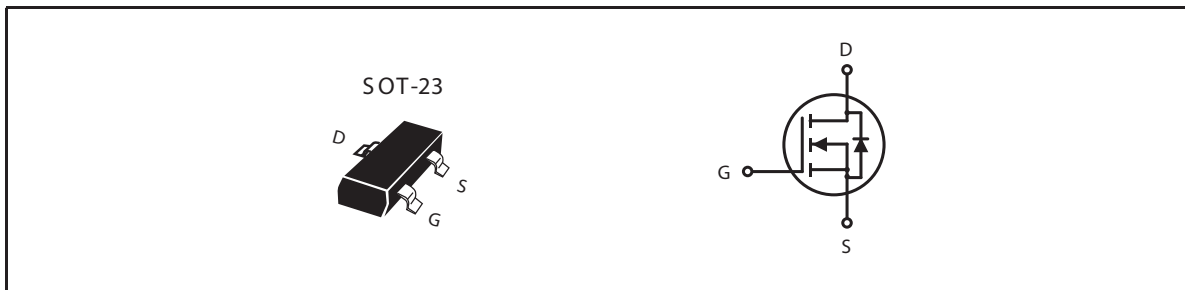

**N-Channel Enhancement Mode Field Effect Transistor****PRODUCT SUMMARY**

V _{DS}	I _D	R _{DS(ON)} (mΩ) Max
30V	4A	50 @ V _{GS} =10V
		60 @ V _{GS} =4.5V
		75 @ V _{GS} =2.5V

FEATURES

- Super high dense cell design for low R_{DS(ON)}.
- Rugged and reliable.
- SOT-23 package.

**ABSOLUTE MAXIMUM RATINGS (T_A=25°C unless otherwise noted)**

Symbol	Parameter	Limit	Units
V _{DS}	Drain-Source Voltage	30	V
V _{GS}	Gate-Source Voltage	±12	V
I _D	Drain Current-Continuous ^a	4	A
I _{DM}	-Pulsed ^b	15	A
P _D	Maximum Power Dissipation ^a	1.25	W
T _J , T _{STG}	Operating Junction and Storage Temperature Range	-55 to 150	°C

THERMAL CHARACTERISTICS

R _{θJA}	Thermal Resistance, Junction-to-Ambient ^a	100	°C/W
------------------	--	-----	------

STS3414

Ver 1.1

ELECTRICAL CHARACTERISTICS (TA=25°C unless otherwise noted)

Symbol	Parameter	Conditions	Min	Typ	Max	Units
OFF CHARACTERISTICS						
BV _{DSS}	Drain-Source Breakdown Voltage	V _{GS} =0V, I _D =250uA	30			V
I _{DSS}	Zero Gate Voltage Drain Current	V _{DS} =24V, V _{GS} =0V			1	uA
I _{GSS}	Gate-Body Leakage Current	V _{GS} = ±12V, V _{DS} =0V			±100	nA
ON CHARACTERISTICS						
V _{GS(th)}	Gate Threshold Voltage	V _{DS} =V _{GS} , I _D =250uA	0.5	0.9	1.2	V
R _{DS(ON)}	Drain-Source On-State Resistance	V _{GS} =10V, I _D =4A		37	50	m ohm
		V _{GS} =4.5V, I _D =3A		45	60	m ohm
		V _{GS} =2.5V, I _D =1A		50	75	m ohm
g _{FS}	Forward Transconductance	V _{DS} =5.0V, I _D =4A		13		S
DYNAMIC CHARACTERISTICS ^c						
C _{ISS}	Input Capacitance	V _{DS} =15V, V _{GS} =0V f=1.0MHz		440		pF
C _{OSS}	Output Capacitance			62		pF
C _{RSS}	Reverse Transfer Capacitance			37		pF
SWITCHING CHARACTERISTICS ^c						
t _{D(ON)}	Turn-On Delay Time	V _{DD} =5V I _D =1A V _{GS} =10V R _{GEN} =6 ohm		4		ns
t _r	Rise Time			8		ns
t _{D(OFF)}	Turn-Off Delay Time			43		ns
t _f	Fall Time			5		ns
Q _g	Total Gate Charge	V _{DS} =15V, I _D =4A, V _{GS} =10V		9.3		nC
		V _{DS} =15V, I _D =4A, V _{GS} =4.5V		4.6		nC
Q _{gs}	Gate-Source Charge	V _{DS} =15V, I _D =4A, V _{GS} =4.5V		1		nC
Q _{gd}	Gate-Drain Charge			1.4		nC
DRAIN-SOURCE DIODE CHARACTERISTICS AND MAXIMUM RATINGS						
I _S	Maximum Continuous Drain-Source Diode Forward Current				1.25	A
V _{SD}	Diode Forward Voltage ^b	V _{GS} =0V, I _S =1.25A		0.82	1.2	V
Notes						
a.Surface Mounted on FR4 Board, t ≤ 10sec.						
b.Pulse Test:Pulse Width ≤ 300us, Duty Cycle ≤ 2%.						
c.Guaranteed by design, not subject to production testing.						

Jan,16,2009

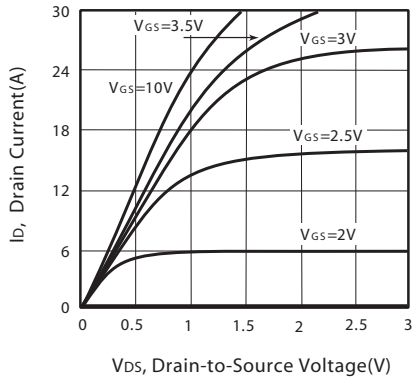

Figure 1. Output Characteristics

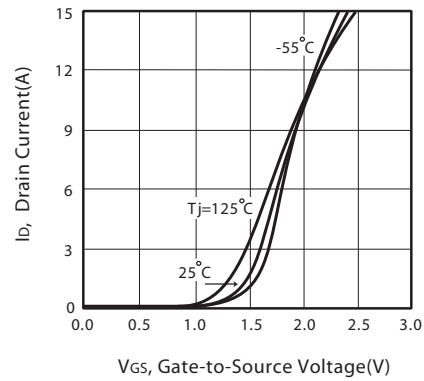

Figure 2. Transfer Characteristics

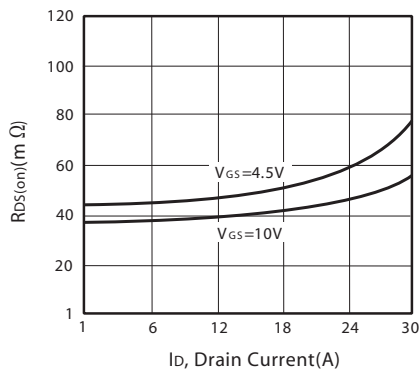

Figure 3. On-Resistance vs. Drain Current and Gate Voltage

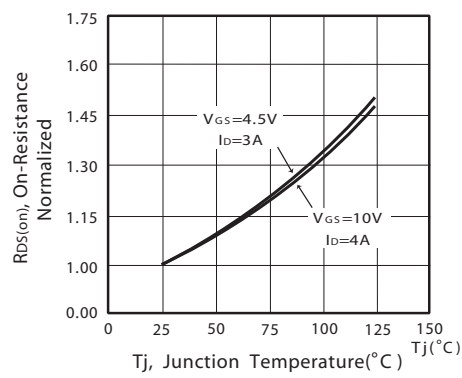

Figure 4. On-Resistance Variation with Drain Current and Temperature

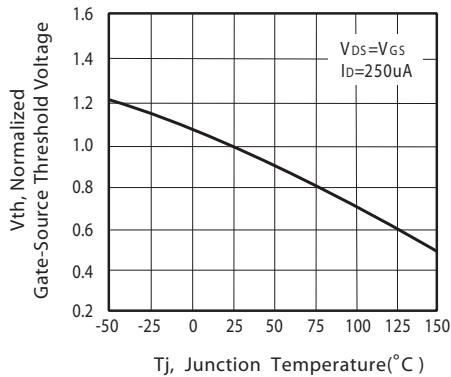

Figure 5. Gate Threshold Variation with Temperature

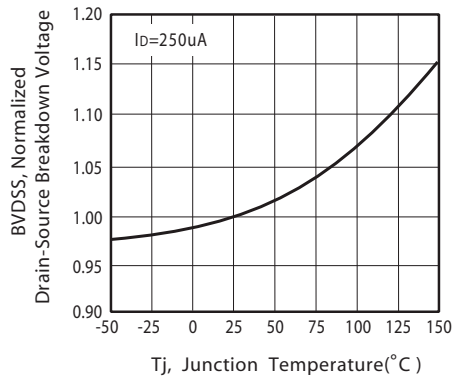

Figure 6. Breakdown Voltage Variation with Temperature

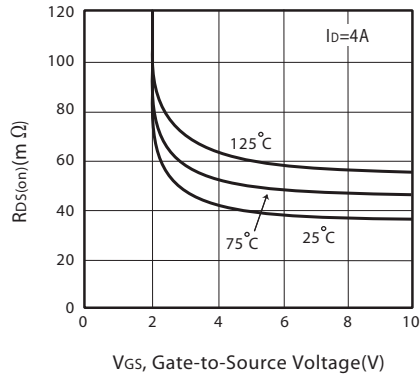

Figure 7. On-Resistance vs. Gate-Source Voltage

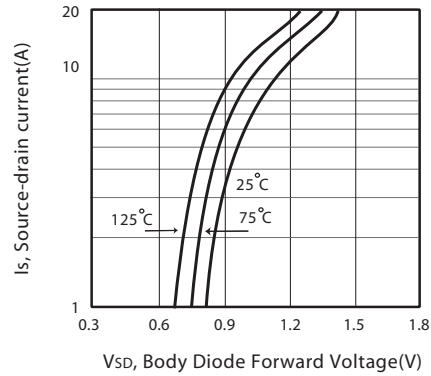

Figure 8. Body Diode Forward Voltage Variation with Source Current

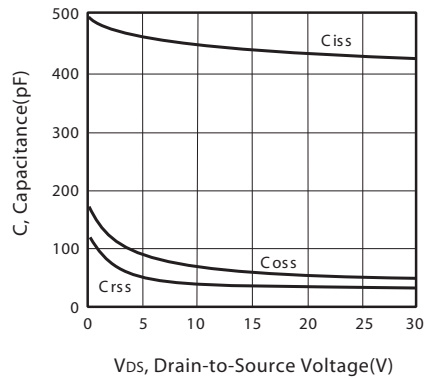

Figure 9. Capacitance

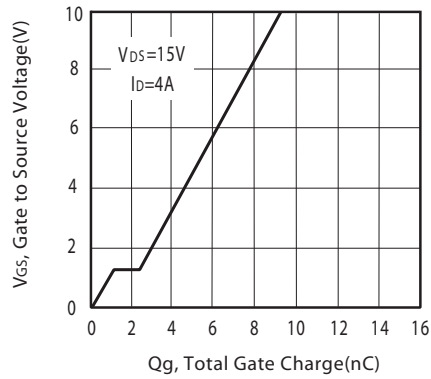

Figure 10. Gate Charge

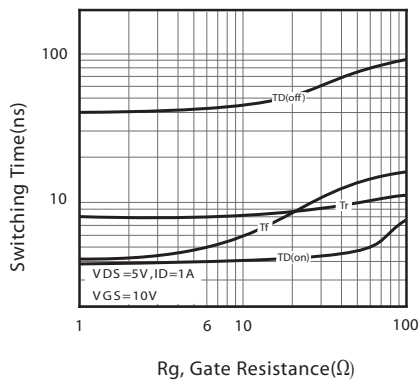

Figure 11. switching characteristics

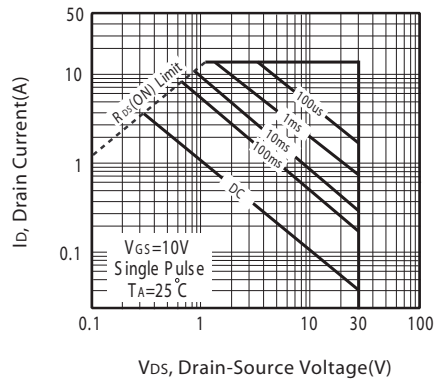

Figure 12. Maximum Safe Operating Area

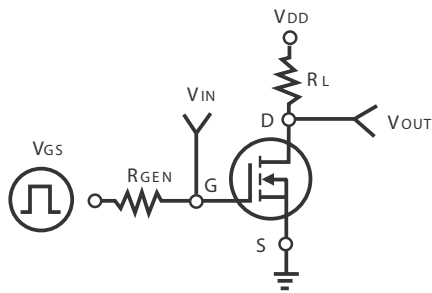

Figure 13. Switching Test Circuit

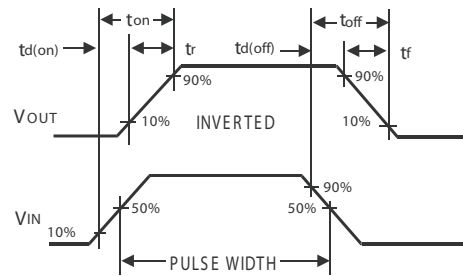
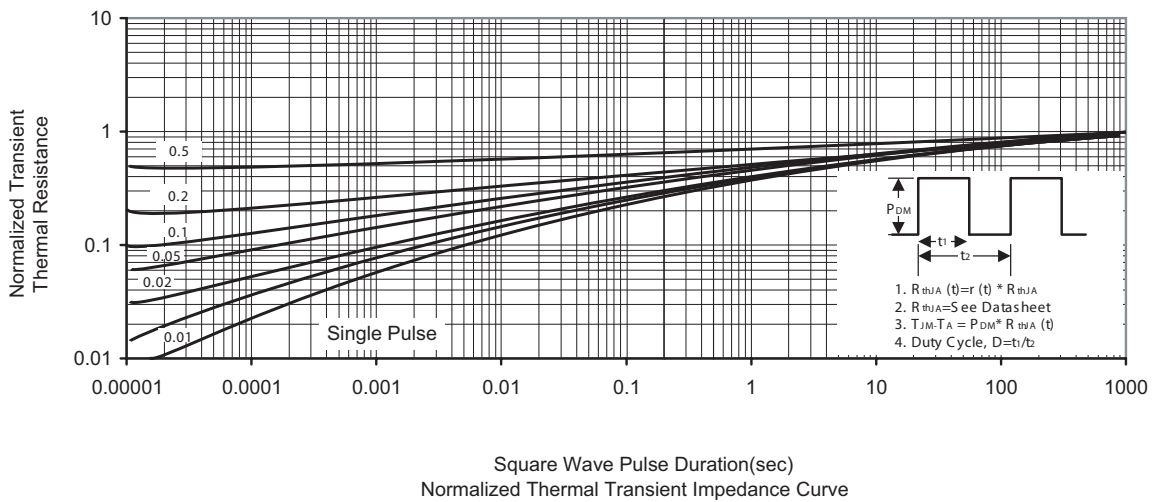
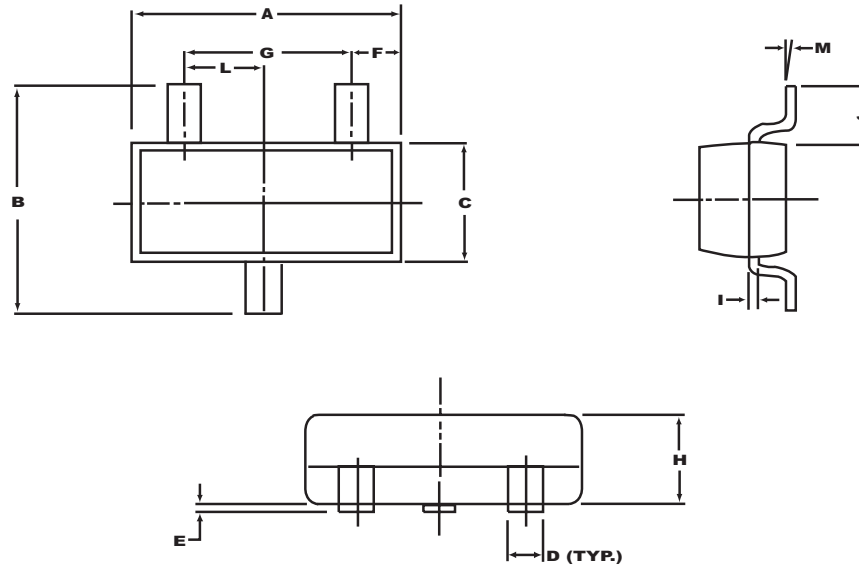

Figure 14. Switching Waveforms



PACKAGE OUTLINE DIMENSIONS

SOT 23



SYMBOLS	MILLIMETERS		INCHES	
	MIN	MAX	MIN	MAX
A	2.70	3.10	0.106	0.122
B	2.40	2.80	0.094	0.110
C	1.40	1.60	0.055	0.063
D	0.35	0.50	0.014	0.020
E	0	0.10	0	0.004
F	0.45	0.55	0.018	0.022
G	1.90 REF.		0.075 REF.	
H	1.00	1.30	0.039	0.051
I	0.10	0.20	0.004	0.008
J	0.40	-	0.016	-
L	0.45	1.15	0.033	0.045
M	0°	10°	0°	10°

SOT-23 Tape and Reel Data

SOT-23 Carrier Tape

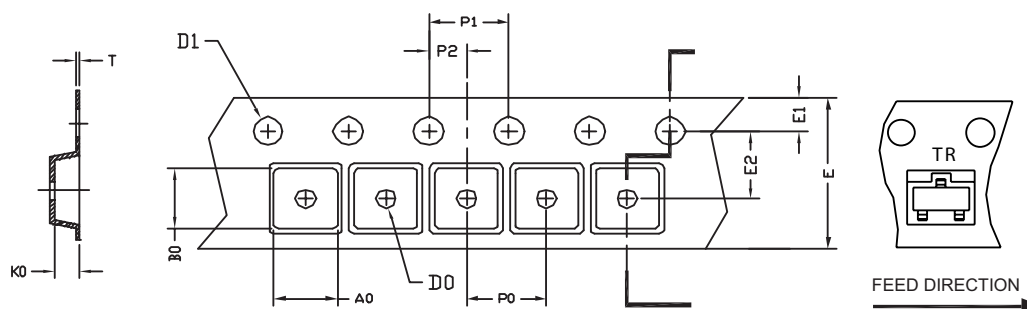

UNIT:mm

PACKAGE	A0	B0	K0	D0	D1	E	E1	E2	P0	P1	P2	T
SOT-23	3.20 ±0.10	3.00 ±0.10	1.33 ±0.10	1.00 +0.25	1.50 +0.10	8.00 +0.30 -0.10	1.75 ±0.10	3.50 ±0.05	4.00 ±0.10	4.00 ±0.10	2.00 ±0.05	0.20 ±0.02

SOT-23 Reel

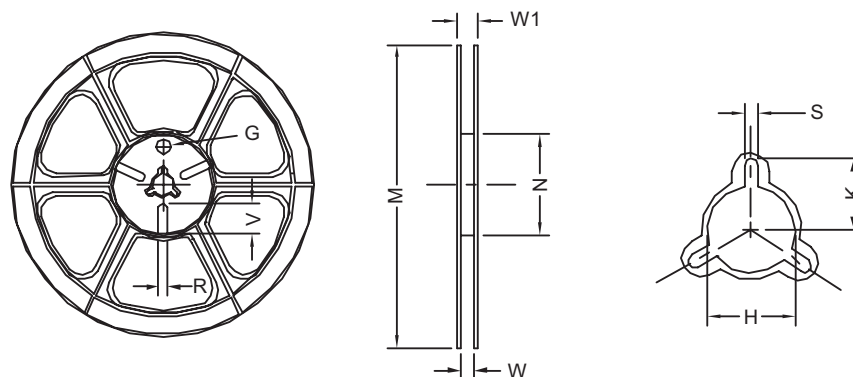

UNIT:mm

TAPE SIZE	REEL SIZE	M	N	W	W1	H	K	S	G	R	V
8mm	178	178 ±1	60 ±1	9.00 ±0.5	12.00 ±0.5	13.5 ±0.5	10.5	2.00 ±0.5	10.0	5.00	18.00