



## N-Channel Enhancement Mode Field Effect Transistor

### PRODUCT SUMMARY

VDSS	ID	RDS(ON) (mΩ) Max
30V	4.6A	30@ VGS = 10V 42@ VGS =4.5V

### FEATURES

- Super high dense cell design for low RDS(ON).
- Rugged and reliable.
- SOT-23 package.



### ABSOLUTE MAXIMUM RATINGS (TA=25 C° unless otherwise noted)

Parameter	Symbol	Limit	Unit
Drain-Source Voltage	VDS	30	V
Gate-Source Voltage	VGS	± 20	V
Drain Current-Continuous <sup>a</sup> @ TJ=125°C -Pulsed <sup>b</sup>	ID	4.6	A
	IDM	16	A
Drain-Source Diode Forward Current <sup>a</sup>	IS	1.25	A
Maximum Power Dissipation <sup>a</sup>	PD	1.25	W
Operating Junction and Storage Temperature Range	TJ, TSTG	-55 to 150	°C

### THERMAL CHARACTERISTICS

Thermal Resistance, Junction-to-Ambient <sup>a</sup>	RthJA	100	°C/W
--	-------	-----	------

# STS 3402

ELECTRICAL CHARACTERISTICS (T<sub>A</sub> = 25 °C unless otherwise noted)

Parameter	Symbol	Condition	Min	Typ <sup>c</sup>	Max	Unit
OFF CHARACTERISTICS						
Drain-Source Breakdown Voltage	B <sub>VDS</sub>	V <sub>GS</sub> = 0V, I <sub>D</sub> = 250uA	30			V
Zero Gate Voltage Drain Current	I <sub>DSS</sub>	V <sub>DS</sub> = 24V, V <sub>GS</sub> = 0V			1	uA
Gate-Body Leakage	I <sub>GSS</sub>	V <sub>GS</sub> = ± 20V, V <sub>DS</sub> = 0V			±100	nA
ON CHARACTERISTICS <sup>b</sup>						
Gate Threshold Voltage	V <sub>GS(th)</sub>	V <sub>DS</sub> = V <sub>GS</sub> , I <sub>D</sub> = 250uA	1	1.5	2.5	V
Drain-Source On-State Resistance	R <sub>DS(ON)</sub>	V <sub>GS</sub> = 10V, I <sub>D</sub> = 4.6A		26	30	m-ohm
		V <sub>GS</sub> = 4.5V, I <sub>D</sub> = 4.0A		38	42	m-ohm
On-State Drain Current	I <sub>D(ON)</sub>	V <sub>DS</sub> = 5V, V <sub>GS</sub> = 4.5V	10			A
Forward Transconductance	g <sub>FS</sub>	V <sub>DS</sub> = 5V, I <sub>D</sub> = 4.6A		5		S
DYNAMIC CHARACTERISTICS <sup>c</sup>						
Input Capacitance	C <sub>ISS</sub>	V <sub>DS</sub> = 15V, V <sub>GS</sub> = 0V f = 1.0MHz		782		pF
Output Capacitance	C <sub>OSS</sub>			135		pF
Reverse Transfer Capacitance	C <sub>RSS</sub>			93		pF
SWITCHING CHARACTERISTICS <sup>c</sup>						
Turn-On Delay Time	t <sub>D(ON)</sub>	V <sub>DD</sub> = 15V, I <sub>D</sub> = 1A, V <sub>GS</sub> = 10V, R <sub>L</sub> = 15 ohm R <sub>GEN</sub> = 6 ohm		4.8		ns
Rise Time	t <sub>r</sub>			3.9		ns
Turn-Off Delay Time	t <sub>D(OFF)</sub>			27.7		ns
Fall Time	t <sub>f</sub>			5.5		ns
Total Gate Charge	Q <sub>g</sub>	V <sub>DS</sub> = 15V, I <sub>D</sub> = 4.6A, V <sub>GS</sub> = 10V		15.8		nC
Gate-Source Charge	Q <sub>gs</sub>			2		nC
Gate-Drain Charge	Q <sub>gd</sub>			3		nC

# STS 3402

## ELECTRICAL CHARACTERISTICS ( $T_A=25^\circ\text{C}$ unless otherwise noted)

Parameter	Symbol	Condition	Min	Typ <sup>c</sup>	Max	Unit
DRAIN-SOURCE DIODE CHARACTERISTICS <sup>b</sup>						
Diode Forward Voltage	$V_{SD}$	$V_{GS} = 0V, I_S = 1.25A$		0.78	1.2	V

### Notes

- a. Surface Mounted on FR4 Board,  $t \leq 10\text{sec}$ .
- b. Pulse Test: Pulse Width  $\leq 300\mu\text{s}$ , Duty Cycle  $\leq 2\%$ .
- c. Guaranteed by design, not subject to production testing.

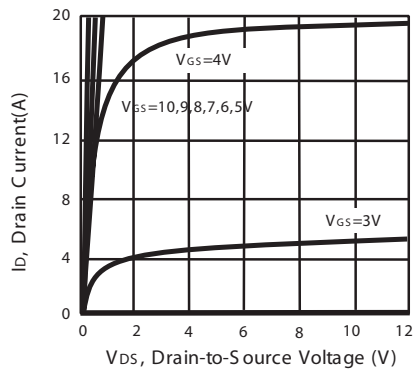

Figure 1. Output Characteristics

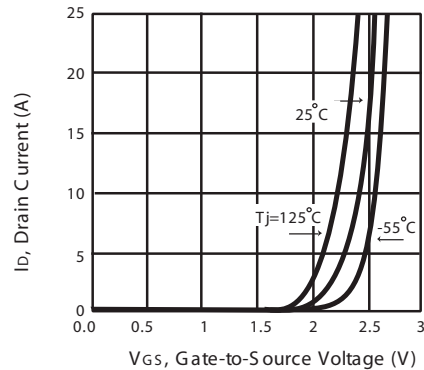

Figure 2. Transfer Characteristics

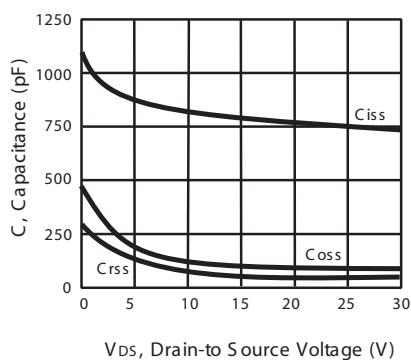

Figure 3. Capacitance

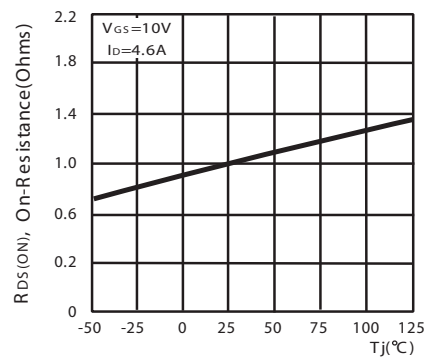
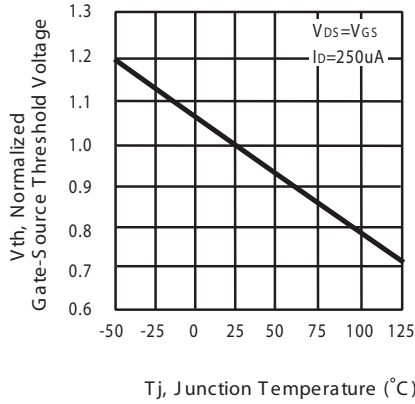

Figure 4. On-Resistance Variation with Temperature

# STS 3402



with Temperature

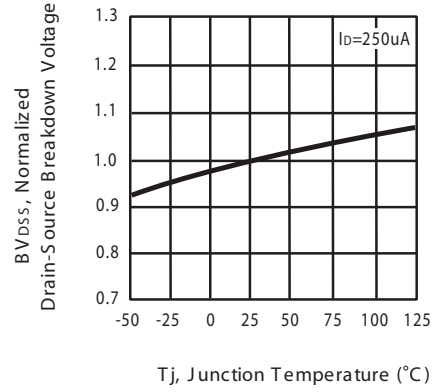

Figure 6. Breakdown Voltage Variation with Temperature

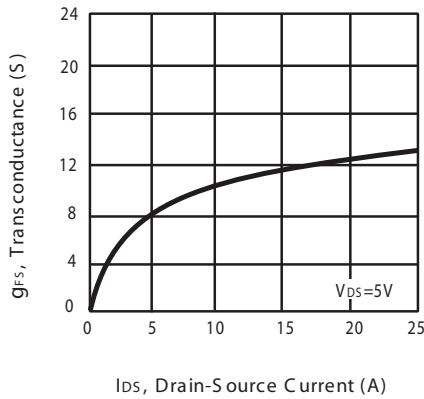

Figure 7. Transconductance Variation with Drain Current

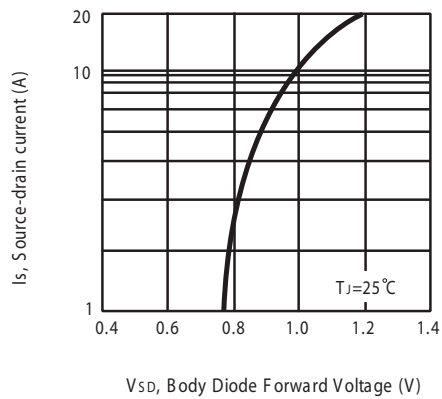

Figure 8. Body Diode Forward Voltage Variation with Source Current

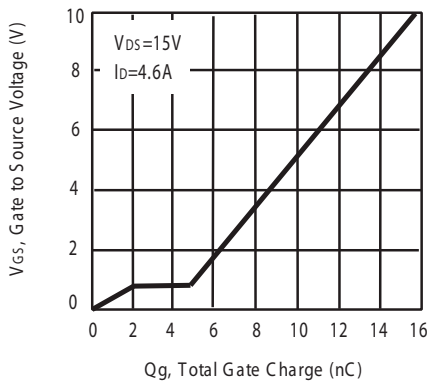

Figure 9. Gate Charge

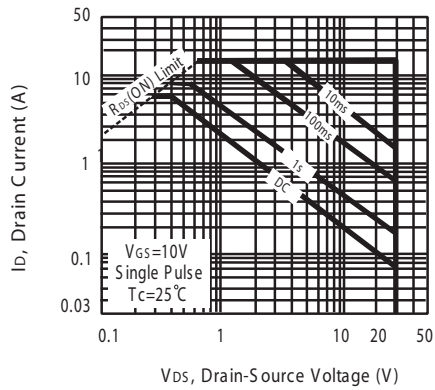

Figure 10. Maximum Safe Operating Area

# STS 3402

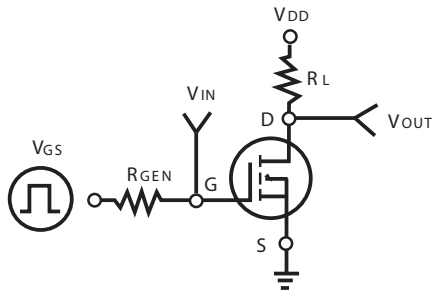

Figure 11. Switching Test Circuit

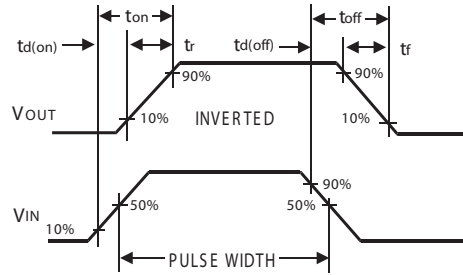
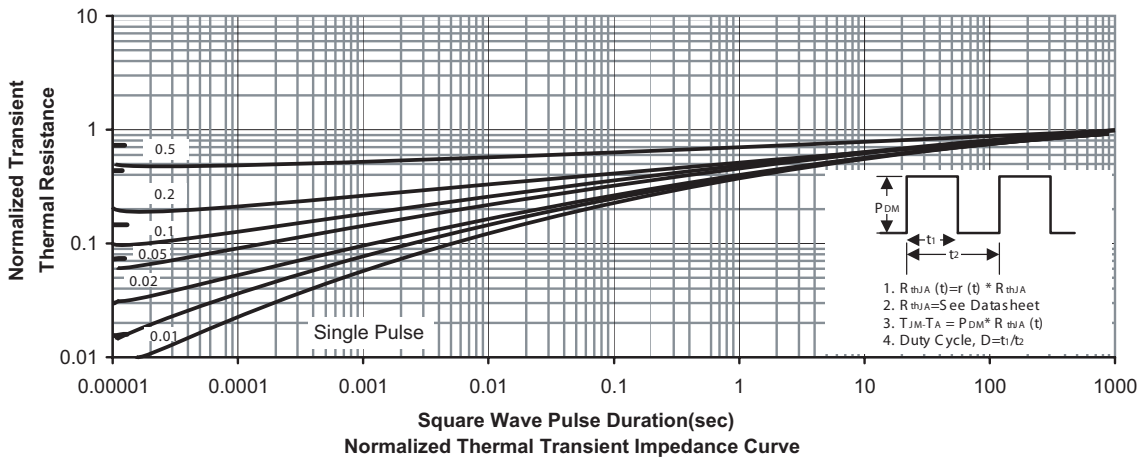

Figure 12. Switching Waveforms



# STS 3402

## PACKAGE OUTLINE DIMENSIONS

### SOT-23

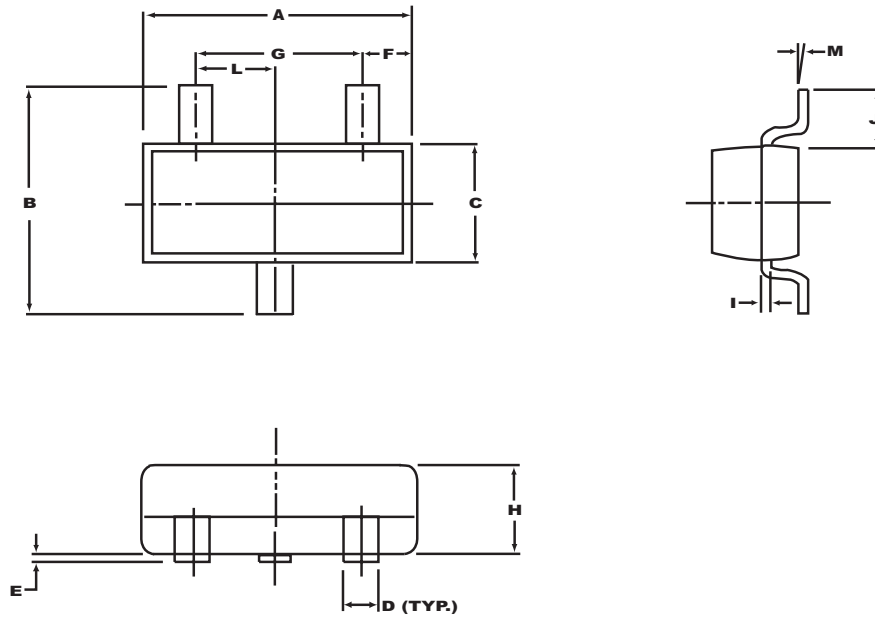

SYMBOLS	MILLIMETERS		INCHES	
	MIN	MAX	MIN	MAX
A	2.70	3.10	0.106	0.122
B	2.40	2.80	0.094	0.110
C	1.40	1.60	0.055	0.063
D	0.35	0.50	0.014	0.020
E	0	0.10	0	0.004
F	0.45	0.55	0.018	0.022
G	1.90 REF.		0.075 REF.	
H	1.00	1.30	0.039	0.051
I	0.10	0.20	0.004	0.008
J	0.40	-	0.016	-
L	0.45	1.15	0.033	0.045
M	0°	10°	0°	10°

# STS 3402

## SOT-23 Tape and Reel Data

### SOT-23 Carrier Tape

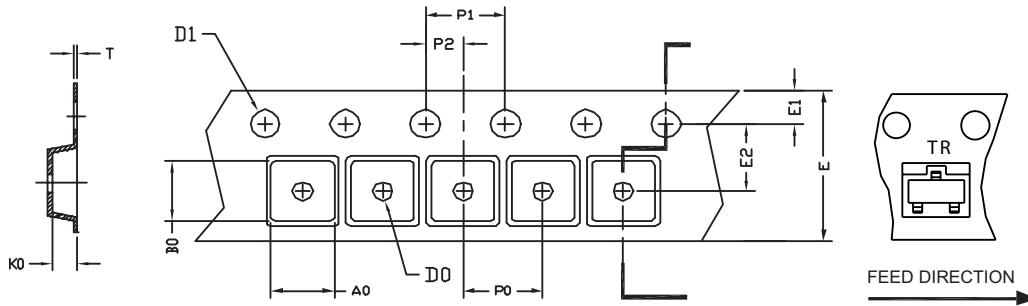

UNIT:mm

PACKAGE	A0	B0	K0	D0	D1	E	E1	E2	P0	P1	P2	T
SOT-23	3.20 $\pm 0.10$	3.00 $\pm 0.10$	1.33 $\pm 0.10$	$\phi$ 1.00 $\pm 0.25$	$\phi$ 1.50 $\pm 0.10$	8.00 $+0.30$ $-0.10$	1.75 $\pm 0.10$	3.50 $\pm 0.05$	4.00 $\pm 0.10$	4.00 $\pm 0.10$	2.00 $\pm 0.05$	0.20 $\pm 0.02$

### SOT-23 Reel

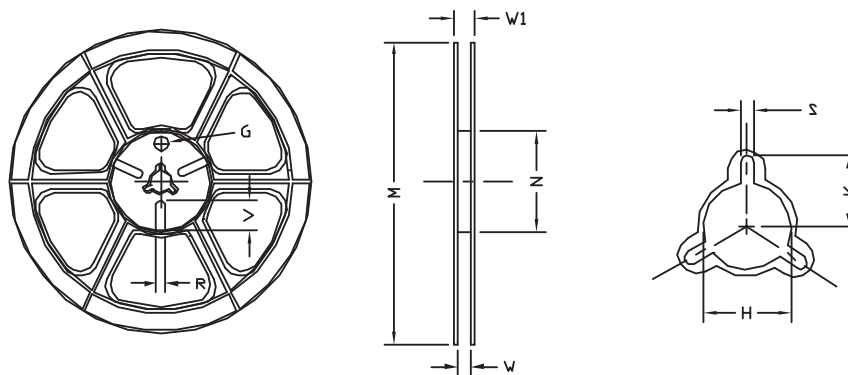

UNIT:mm

TAPE SIZE	REEL SIZE	M	N	W	W1	H	K	S	G	R	V
8mm	$\phi$ 178	$\phi$ 178 $\pm 1$	$\phi$ 60 $\pm 1$	9.00 $\pm 0.5$	12.00 $\pm 0.5$	$\phi$ 13.5 $\pm 0.5$	10.5	2.00 $\pm 0.5$	$\phi$ 10.0	5.00	18.00