



## P-Channel Enhancement Mode MOSFET

PRODUCT SUMMARY		
V <sub>DS</sub>	I <sub>D</sub>	R <sub>DS(ON)</sub> (mΩ) Max
-30V	-3A	75 @ V <sub>GS</sub> = -10V
		100 @ V <sub>GS</sub> = -4.5V

### FEATURES

- Super high dense cell design for low R<sub>DS(ON)</sub>.
- Rugged and reliable.
- SOT-23 Package.

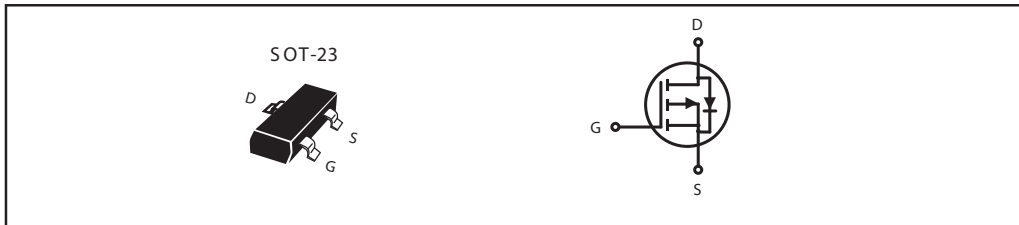

### ABSOLUTE MAXIMUM RATINGS (T<sub>A</sub>=25°C unless otherwise noted)

Parameter	Symbol	Limit	Unit
Drain-Source Voltage	V <sub>DS</sub>	- 30	V
Gate-Source Voltage	V <sub>GS</sub>	± 20	V
Drain Current-Continuous <sup>a</sup> @ T <sub>J</sub> =125°C -Pulsed <sup>b</sup>	I <sub>D</sub>	- 3	A
	I <sub>DM</sub>	- 10	A
Drain-Source Diode Forward Current <sup>a</sup>	I <sub>S</sub>	-1.25	A
Maximum Power Dissipation <sup>a</sup>	PD	1.25	W
Operating Junction and Storage Temperature Range	T <sub>J</sub> , T <sub>STG</sub>	-55 to 150	°C

### THERMAL CHARACTERISTICS

Thermal Resistance, Junction-to-Ambient <sup>a</sup>	R <sub>θJA</sub>	100	°C/W
--	------------------	-----	------

# STS3401

ELECTRICAL CHARACTERISTICS (T<sub>A</sub> = 25°C unless otherwise noted)

Parameter	Symbol	Condition	Min	Typ <sup>c</sup>	Max	Unit
<b>OFF CHARACTERISTICS</b>						
Drain-Source Breakdown Voltage	BV <sub>DSS</sub>	V <sub>GS</sub> = 0V, I <sub>D</sub> = -250uA	-30			V
Zero Gate Voltage Drain Current	I <sub>DSS</sub>	V <sub>DS</sub> = -24V, V <sub>GS</sub> = 0V			-1	uA
Gate-Body Leakage	I <sub>GSS</sub>	V <sub>GS</sub> = ±20V, V <sub>DS</sub> = 0V			±100	nA
<b>ON CHARACTERISTICS<sup>b</sup></b>						
Gate Threshold Voltage	V <sub>GS(th)</sub>	V <sub>DS</sub> = V <sub>GS</sub> , I <sub>D</sub> = -250uA	-1	-1.5	-2.5	V
Drain-Source On-State Resistance	R <sub>DS(ON)</sub>	V <sub>GS</sub> = -10V, I <sub>D</sub> = -3A			75	m-ohm
		V <sub>GS</sub> = -4.5V, I <sub>D</sub> = -2A			100	m-ohm
On-State Drain Current	I <sub>D(ON)</sub>	V <sub>DS</sub> = -5V, V <sub>GS</sub> = -10V	6			A
Forward Transconductance	g <sub>FS</sub>	V <sub>DS</sub> = -5V, I <sub>D</sub> = -3A		5		S
<b>DYNAMIC CHARACTERISTICS<sup>c</sup></b>						
Input Capacitance	C <sub>ISS</sub>	V <sub>DS</sub> = -15V, V <sub>GS</sub> = 0V f = 1.0MHz		653		pF
Output Capacitance	C <sub>OSS</sub>			130		pF
Reverse Transfer Capacitance	C <sub>RSS</sub>			97		pF
<b>SWITCHING CHARACTERISTICS<sup>c</sup></b>						
Turn-On Delay Time	t <sub>D(ON)</sub>	V <sub>D</sub> = -15V, I <sub>D</sub> = -1A, V <sub>GEN</sub> = -10V, R <sub>GEN</sub> = 6 ohm R <sub>L</sub> = 15 ohm		13		ns
Rise Time	t <sub>r</sub>			7		ns
Turn-Off Delay Time	t <sub>D(OFF)</sub>			58		ns
Fall Time	t <sub>f</sub>			26		ns
Total Gate Charge	Q <sub>g</sub>	V <sub>DS</sub> = -15V, I <sub>D</sub> = -3A, V <sub>GS</sub> = -10V		13.5		nC
		V <sub>DS</sub> = -15V, I <sub>D</sub> = -3A, V <sub>GS</sub> = -4.5V		7		nC
Gate-Source Charge	Q <sub>gs</sub>	V <sub>DS</sub> = -15V, I <sub>D</sub> = -3A, V <sub>GS</sub> = -10V		2.3		nC
Gate-Drain Charge	Q <sub>gd</sub>			2.8		nC

# STS 3401

ELECTRICAL CHARACTERISTICS ( $T_A=25^\circ\text{C}$  unless otherwise noted)

Parameter	Symbol	Condition	Min	Typ <sup>c</sup>	Max	Unit
DRAIN-SOURCE DIODE CHARACTERISTICS <sup>b</sup>						
Diode Forward Voltage	$V_{SD}$	$V_{GS} = 0V, I_S = -1.25A$		-0.8	-1.2	V

## Notes

- a. Surface Mounted on FR4 Board,  $t \leq 10\text{sec}$ .
- b. Pulse Test: Pulse Width  $\leq 300\mu\text{s}$ , Duty Cycle  $\leq 2\%$ .
- c. Guaranteed by design, not subject to production testing.

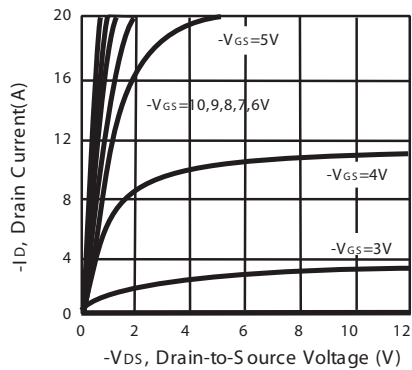

Figure 1. Output Characteristics

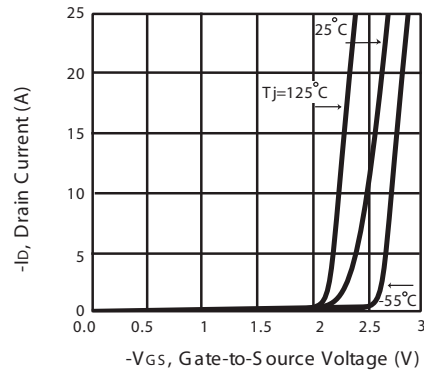

Figure 2. Transfer Characteristics

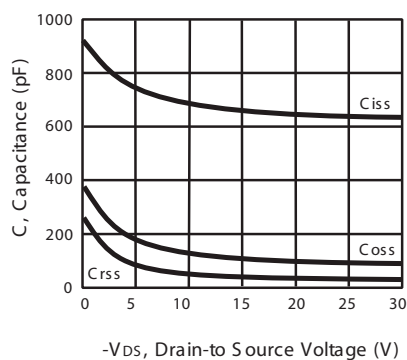

Figure 3. Capacitance

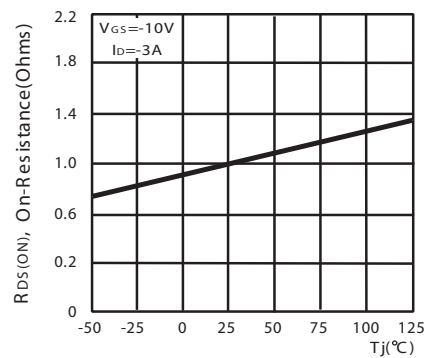
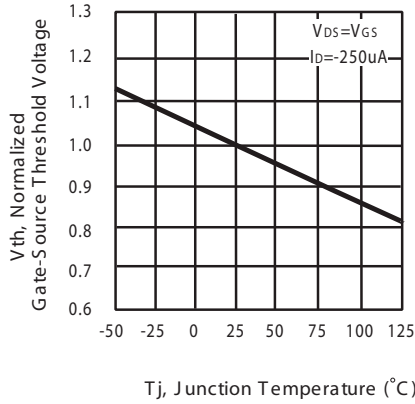

Figure 4. On-Resistance Variation with Temperature

# STS 3401



with Temperature

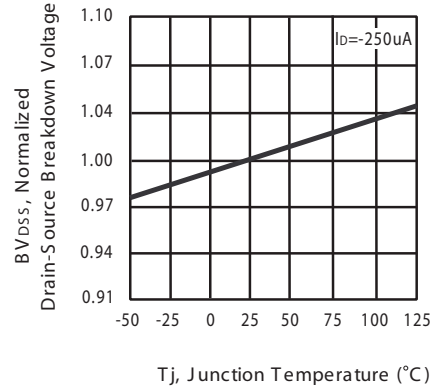

Figure 6. Breakdown Voltage Variation with Temperature

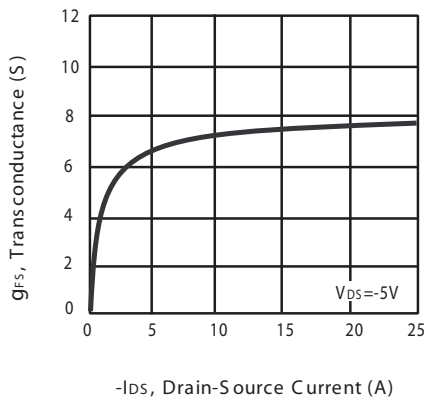

Figure 7. Transconductance Variation with Drain Current

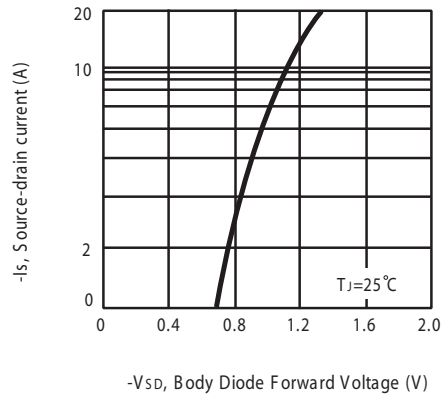

Figure 8. Body Diode Forward Voltage Variation with Source Current

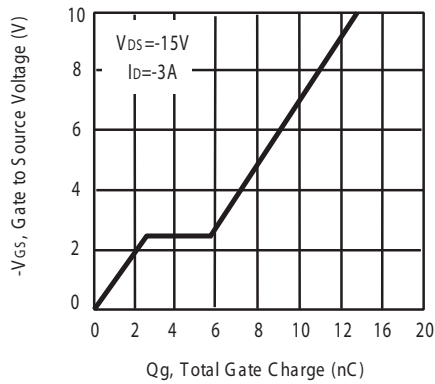

Figure 9. Gate Charge

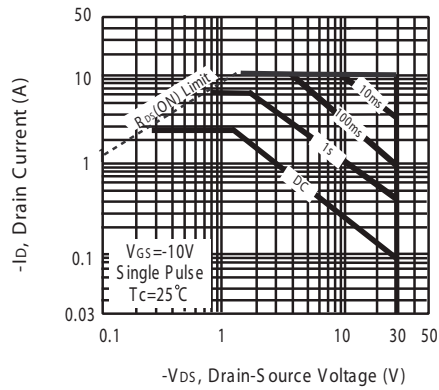

Figure 10. Maximum Safe Operating Area

# STS3401

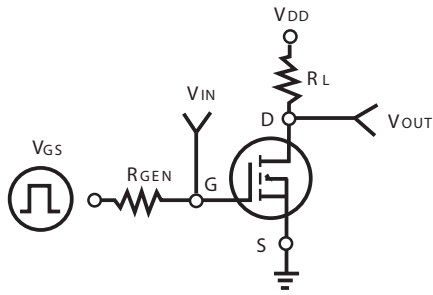

Figure 11. Switching Test Circuit

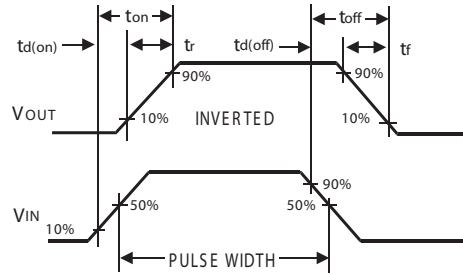
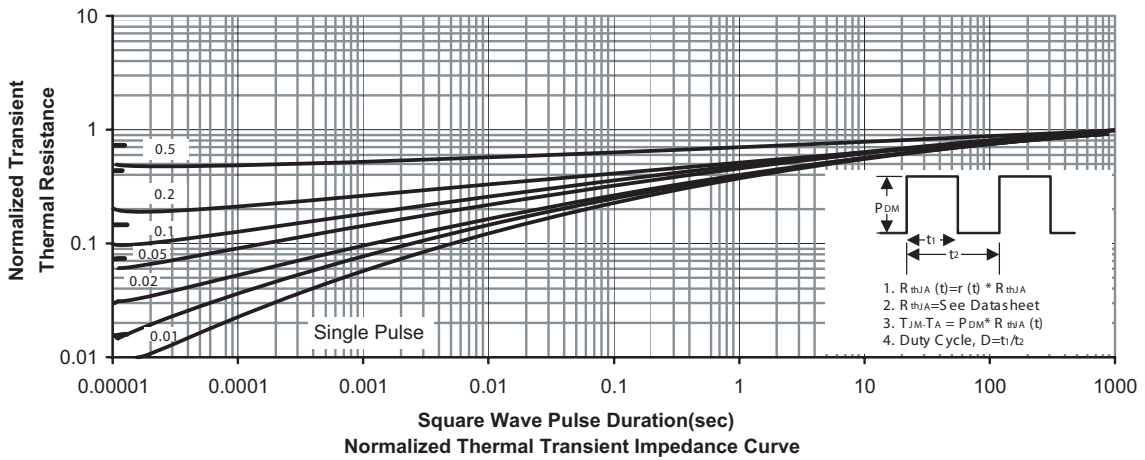

Figure 12. Switching Waveforms



# STS 3401

## PACKAGE OUTLINE DIMENSIONS

### SOT-23

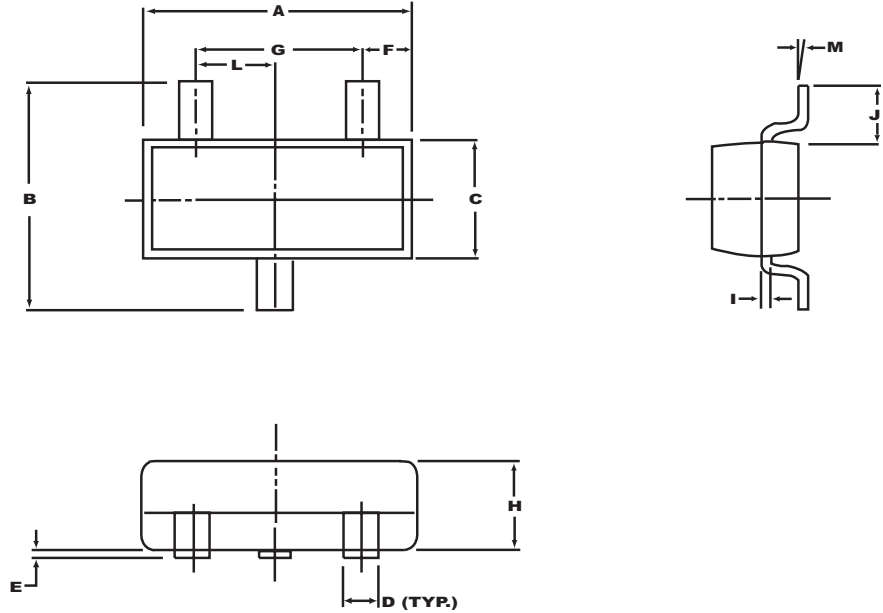

SYMBOLS	MILLIMETERS		INCHES	
	MIN	MAX	MIN	MAX
A	2.70	3.10	0.106	0.122
B	2.40	2.80	0.094	0.110
C	1.40	1.60	0.055	0.063
D	0.35	0.50	0.014	0.020
E	0	0.10	0	0.004
F	0.45	0.55	0.018	0.022
G	1.90 REF.		0.075 REF.	
H	1.00	1.30	0.039	0.051
I	0.10	0.20	0.004	0.008
J	0.40	-	0.016	-
L	0.45	1.15	0.033	0.045
M	0°	10°	0°	10°

# STS 3401

## SOT-23 Tape and Reel Data

### SOT-23 Carrier Tape

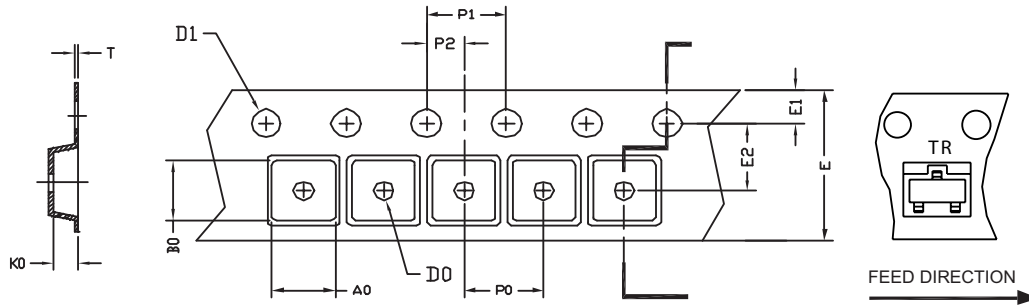

UNIT:mm

PACKAGE	A0	B0	K0	D0	D1	E	E1	E2	P0	P1	P2	T
SOT-23	3.20 $\pm 0.10$	3.00 $\pm 0.10$	1.33 $\pm 0.10$	$\phi$ 1.00 $\pm 0.25$	$\phi$ 1.50 $\pm 0.10$	8.00 $+0.30$ $-0.10$	1.75 $\pm 0.10$	3.50 $\pm 0.05$	4.00 $\pm 0.10$	4.00 $\pm 0.10$	2.00 $\pm 0.05$	0.20 $\pm 0.02$

### SOT-23 Reel

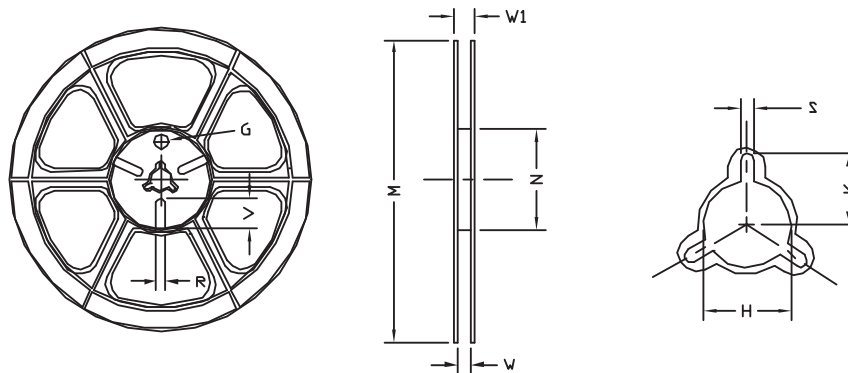

UNIT:mm

TAPE SIZE	REEL SIZE	M	N	W	W1	H	K	S	G	R	V
8mm	$\phi$ 178	$\phi$ 178 $\pm 1$	$\phi$ 60 $\pm 1$	9.00 $\pm 0.5$	12.00 $\pm 0.5$	$\phi$ 13.5 $\pm 0.5$	10.5	2.00 $\pm 0.5$	$\phi$ 10.0	5.00	18.00